

**metos**  
kitchen intelligence<sup>™</sup>

# Cooking and Distribution Equipment Nordien-System Dishroom Equipment

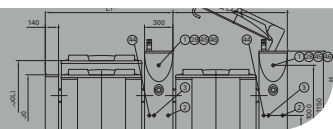



## Contents

### Cooking Equipment

Proveno kettles.....	8
Proveno Climatic kettles .....	20
Culino kettles.....	22
Viking kettles.....	26
Menu kettles .....	28
Futura Marvel pressure steamer .....	30

### Ovens

Chef convection ovens.....	32
Chef roasting-baking ovens.....	32

### Ranges and Bratt Pans

Ardox ranges .....	36
Ardox Induction ranges .....	38
RP ranges .....	40
Minor ranges .....	41
Prince bratt pans .....	43
Futura bratt pans .....	44

### HACCP

Metos TempNet.....	46
--------------------	----

### Food Serving

Drop-in collection .....	55
Nova serving lines .....	56
Corona buffet trolleys .....	62
Fresh salad trolley.....	65
Heated & cold plates.....	66
Stand for glasses and cups .....	67
Proff distribution series .....	68
Halo display cases .....	84
CD display cases .....	91

### Tables, Shelves

Tables.....	92
Wall shelves .....	103

### Nordien System

Dishwashing baskets .....	106
Trolleys.....	112
Shelving .....	126
Dishwashing furniture .....	130

### Drawings

Installation drawings.....	138
Nordien System drawings .....	154

**Metos Manufacturing** is a business unit of Metos Group, which is one of the biggest companies in Europe in manufacturing and marketing professional kitchen equipment. The product range comprises equipment for professional food production, such as state-of-the-art combi kettles, induction ranges, pressure steamers, bratt pans and ovens, all designed, developed and manufactured by Metos Manufacturing.

Metos Manufacturing products are available through Metos units in respective countries, and through a network of dedicated distributors. For distributor information, please contact Sales and Marketing.

### **Sales and marketing**

Head Office & Kerava Factory  
Ahjonkaarre  
FI-04220 Kerava, FINLAND  
Tel. + 358 204 3913  
Fax + 358 204 39 4306

Stainless Steel Furniture Factory  
Putkitie 4  
FI-79130 Sorsakoski, FINLAND  
Tel +358 204 3913

Tallinn Factory  
Saha tee 18  
EE-74201 Loo, Harjumaa, ESTONIA  
Tel +372 6 051 340

[international.sales@metos.com](mailto:international.sales@metos.com)  
[www.metos.com/manufacturing](http://www.metos.com/manufacturing)

### **Service and technical support**

Tel. + 358 204 3913  
Fax + 358 204 39 4465  
[technical.support@metos.com](mailto:technical.support@metos.com)

### **Spare parts**

Tel. + 358 204 3913  
Fax + 358 204 39 4434  
[spareparts@metos.com](mailto:spareparts@metos.com)





# Spare Parts and Technical Support Worldwide

## **Long term commitments on Spare Part Services**

Our centralised handling of both products and spares enables us to provide high availability and cost efficiency for thousands of different spare parts. Weekly we send many shipments of spares all around the world. Even for products which no longer are being produced, we guarantee spare part availability for 10 years.

## **Technical Support and Training**

For our international business partners and subsidiaries we have dedicated personnel to provide technical support and spare part services. For our partners we can provide individual installation and service training both centrally in our factory or at the customers site. Along with new products and product developments we provide continuous product training for our own technical support personnel. This way we can make sure that our customers receive accurate and up-to-date technical support and service.

## **Technical Documentation**

Our technical documentation group provides the availability of high standard technical documentations in English.



# Quality and environment

We are committed to environmentally sensitive thinking. In the planning, production and delivery of professional kitchens we continuously develop new, more environmentally friendly solutions. In order to achieve improvements we work closely with customers, suppliers and service companies. We have been actively creating an environmental programme for Metos focusing especially on the following points:

The Metos kettles come equipped with automatic half energy function. There are also five different options for in kettle cooling allowing the user to recycle the cooling water used for food chilling.

We try to minimize the amount of waste produced in the production and delivery of the products by sorting and recycling. All remaining waste, mostly of stainless steel, is recycled.

The environmental impact of discarded products is reduced when the right materials are used in the structures.



Metos has been granted with ISO 9001 quality and ISO 14001 environmental certificates.

# Ergonomic Metos Proveno – designed for heavy use



*High tilting kettle is fast and easy to empty. Most trolleys fit under kettle's pouring lip.*

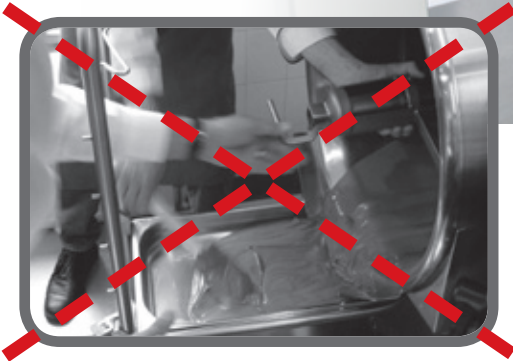

*No more uncomfortable positions.*

*Kettle is ergonomic to clean because of its high tilt.*

*Distance to floor is over 600 mm when kettle is fully tilted.*



# METOS PROVENO

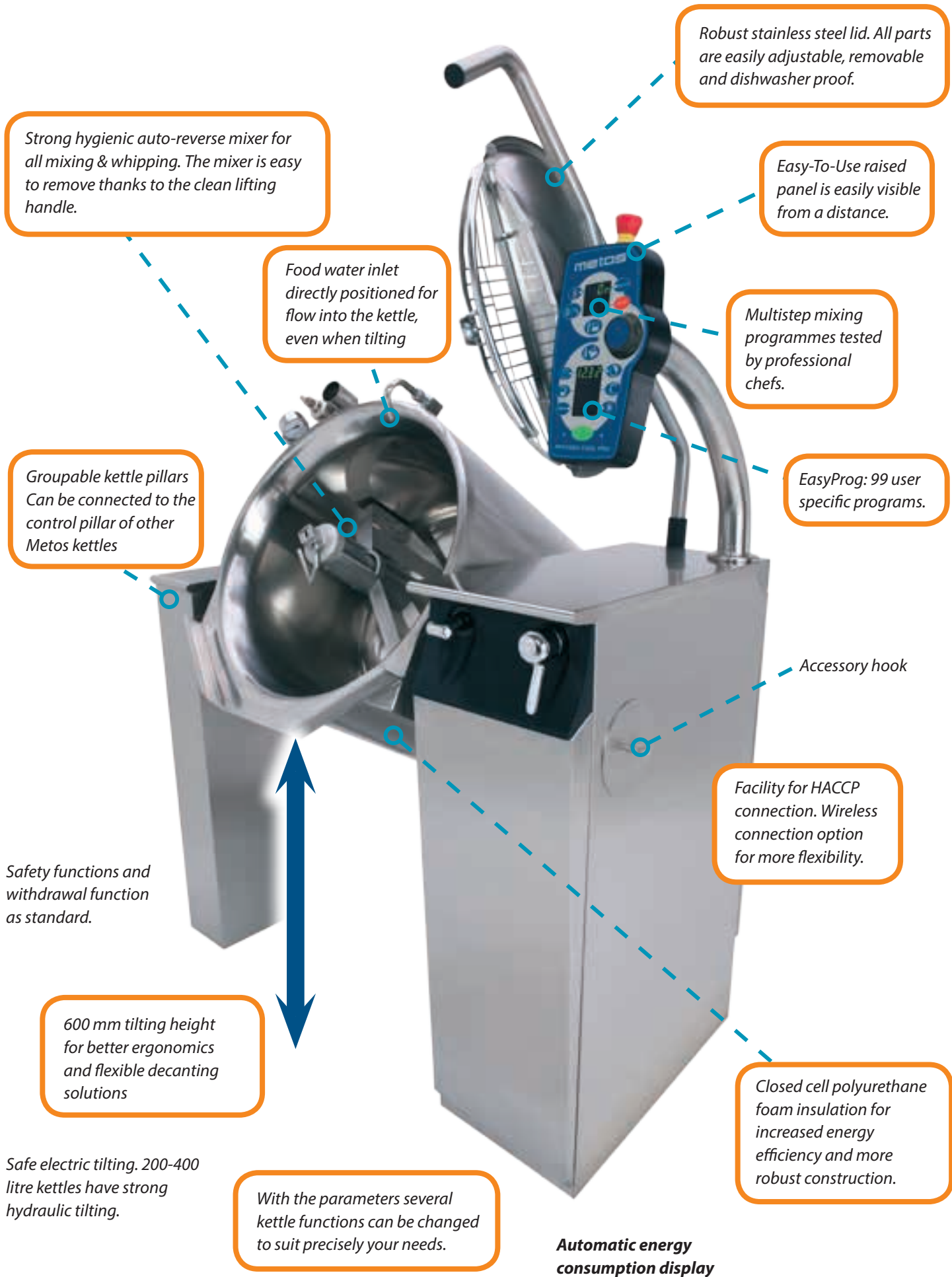

Robust stainless steel lid. All parts are easily adjustable, removable and dishwasher proof.

Easy-To-Use raised panel is easily visible from a distance.

Multistep mixing programmes tested by professional chefs.

EasyProg: 99 user specific programs.

Facility for HACCP connection. Wireless connection option for more flexibility.

Closed cell polyurethane foam insulation for increased energy efficiency and more robust construction.

Strong hygienic auto-reverse mixer for all mixing & whipping. The mixer is easy to remove thanks to the clean lifting handle.

Food water inlet directly positioned for flow into the kettle, even when tilting

Groupable kettle pillars  
Can be connected to the control pillar of other Metos kettles

Safety functions and withdrawal function as standard.

600 mm tilting height for better ergonomics and flexible decanting solutions

Safe electric tilting. 200-400 litre kettles have strong hydraulic tilting.

With the parameters several kettle functions can be changed to suit precisely your needs.

Automatic energy consumption display

## Practical details



*1/1 GN workstation perfect for tools, ingredients, or standardised recipes*

*Unique stainless steel lid. All parts are easily removable and dishwasher proof. A safety grid lid comes as standard.*



Cream soups safely. Handmixer fits firmly to a connection on a special lid and a special smaller mixer tool mixes simultaneously. The lid and the mixer tool for use with handmixer are suitable for all Metos kettles.



Strong, maintenance-free, auto-reverse mixer for all mixing, also whipping (140 rpm.). Large mixing surface mixes thoroughly. The mixer is easy to lift from clean handle. Removable scrapers. All parts are dishwasher safe. Also available as a heavy-duty version for extra heavy loads, standard in 400 litre kettles.



*Raised control panel is clearly visible and it's protected from collisions.*

## Cleaning is easy



*Automatic Burnt Prevent Control prevents food from burning to surfaces. Even milk based food does not stick or scorch. Kettle cleaning is extremely easy.*

*Seamless welding ensures no edges for dirt to hide.*

*Glossy, polished surface is easy to clean with cleaning brush or cleaning tool.*



*All lid parts and mixer tool parts can be washed in dishwasher.*



*Mixer tool holder for MPT-450 trolley helps to clean tool.*



*Heavy tools can be washed in tool wash trolleys, either manually or in a dishwasher.*



*Plenty of hand shower options.*

# Advanced food temperature control is standard in all Provenos

## TempGuard

The food temperature is shown on the display continuously during cooking and cooling. It can be registered automatically for HACCP during the entire process.



**Energy savings:** full power only when needed, otherwise always only half-power. No settings, fully automatic

**Proving of dough** at accurate proving temperature is safe and easy

**No adjusting of the temperature** – TempGuard reacts to temperature changes automatically

**BurnPrevent Control** for better cooking quality and extremely easy cleaning

**More uniform** and faster cooking

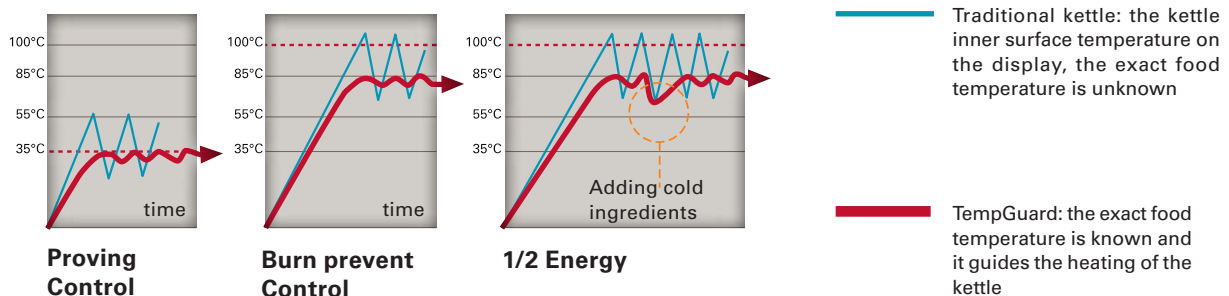

## EasyRun program

**EasyRun** programming using web kettle control panel. One, two or three phase program and Clean+ wash program. The program is automatically saved and can be used later again. Can be programmed up to a week before launch.

## EasyProg programming: 9 phase programs for your favourite recipes

**EasyProg** – programmable fully automatic process without user supervision. Programming is easy using web browser or kettle control panel. Programs can be saved to a USB stick and copied to other kettles.

Recipes can be programmed in 9 phases. Mixing and heating starts automatically at preset time. Also programmable cooking time. Automatic “first water” drainage, automatic fresh water filling for food, automatic Cook & Hold at preset temperature. Safety functions for electricity and water failures. If the process is delayed, it is shown on the display.



### EasyProg

Fully automated multistep cook-chill programming in your Proveno.

**COOK - CHILL**

**CHILL - HOLD**

**CHILL - REHEAT**



Web browser view EasyProg



## Proveno cooling options

**Automatic cooling:** Set target food temperature and start – that’s it! Food temperature continuously on display. Cooling can be interrupted, stopped or target temperature changed during cooling. Automatic stop when the product is not cooled down further with available

cooling media, safety functions to avoid unintentional cooling. Cool & Hold function keeps the food at set temperature. Cooling media can be tap water or ice water from separate ice builder.



### Cooling with ice bank

#### Automatic ice water cooling C3 and C5 – closed circulation

Ice water cooling C3: Cooled water circulates between the ice builder and the kettle’s steam jacket (closed circulation).

Two-phase cooling C5: Cooling starts with tap water, when temperature difference is big and switches over to ice water cooling, when the difference has decreased.



#### Automatic ice water cooling with Proveno Climatic, C3 – closed circulation

In the Metos Proveno Climatic kettle ice water circulates in the kettle’s steam jacket and also in a special climatic mixing tool. Climatic tool shortens cooling time up to 50 %. With the help of the climatic mixing tool you can beat all existing chilling norms by far, for example 200 litre goulash from +98°C to +3°C in about 45 minutes! Metos Proveno Climatic kettle on p. 20.



### Cooling with tap water

#### Automatic cooling with tap water C2 – open circulation

Set target temperature and start – that’s it. Automatic steam jacket drainage after cooling.

\* Kettle does not make water colder for cooling purposes. To achieve 18°C or less, kettle must be connected to an ice bank or fluid chiller.

## Wireless temperature tracking for HACCP

### TempNet®

- Automatic
- Wireless
- Real-time
- Easy to install
- Device independent
- Modular
- Accessed via internet
- 24/7 maintenance
- Incorruptible
- Alarm messages sent as SMS
- Extendable



Metos TempNet, see more on page 46.



# METOS PROVENO



Metos Proveno 80E



Metos Proveno 150E

Metos Proveno	Code	Dimensions mm	Electric connectin
Metos Proveno 40E	4222150	1047x860x1000/1535*	400V 3N~ 12,75 kW 25A
Metos Proveno 60E	4222152	1047x945x1000/1535*	400V 3N~ 16,75 kW 32A
Metos Proveno 80E	4222154	1154x1000x1000/1535*	400V 3N~ 20,75 kW 40A
Metos Proveno 100E	4222156	1154x1000x1000/1535*	400V 3N~ 20,75 kW 40A
Metos Proveno 150E	4222158	1360x1070x1000/1535*	400V 3N~ 25,5 kW 50A
Metos Proveno 200E	4222160	1360x1070x1000/1535*	400V 3N~ 35,5 kW 63A
Metos Proveno 300E	4222162	1560x1270x1000/1535*	400V 3N~ 49,5 kW 100A
Metos Proveno 400E	4222164	1560x1280x1050/1535*	400V 3N~ 59,8 kW 100A

Metos Proveno steam	Code	Dimensions mm	Electric connection	Steam cons.
Metos Proveno 40S	4222701	1047x860x1000/1535*	230V 1~ 1,05 kW 16A	12 kg/h
Metos Proveno 60S	4222702	1047x945x1000/1535*	230V 1~ 1,05 kW 16A	18 kg/h
Metos Proveno 80S	4222703	1154x1000x1000/1535*	230V 1~ 1,05 kW 16A	24 kg/h
Metos Proveno 100S	4222704	1154x1000x1000/1535*	230V 1~ 1,05 kW 16A	30 kg/h
Metos Proveno 150S	4222705	1360x1070x1000/1535*	230V 1~ 1,8 kW 16A	45 kg/h
Metos Proveno 200S	4222706	1360x1070x1000/1535*	400V 3N~ 2 kW 16A	60 kg/h
Metos Proveno 300S	4222707	1560x1270x1000/1535*	400V 3N~ 2 kW 16A	90 kg/h
Metos Proveno 400S	4222708	1560x1280x1050/1535*	400V 3N~ 2,7 kW 16A	120 kg/h

\*control pillar/control panel

Installation frame kits for single kettle	Code
Surface installation frame	4222188
Sub-surface inst. frame	4222190

Installation frame kits for kettle groups	Code
Surface installation frame	4222192
Sub-surface inst. frame	4222194

Adapter to old Proveno frame	Code
Surface installation frame	4222210
Sub-surface inst. frame	4222210

Installation drawing p. 139.

## Standard:

- High tilting kettle (600mm)
- Bottom mixing tool, detachable scrapers
- Safety grid lid
- TempGuard temperature control
- Multi-function timer
- Tilting while mixing function
- Water add when tilting
- Auto tiltback and other custom specific parameters
- USB port on control panel
- Energy optimisation connection
- HACCP facility
- Measuring stick
- Energy consumption measuring on display



# FACTORY OPTIONS FOR METOS KETTLES

## Proveno factory options

Installed at the factory	Code
Food water automatics	4222180
Automatic tap water cooling (C2)	4222168
Ice water cooling, incl. icewater connection (C3)	4222170
Two phase cooling, incl. icewater connection (C5)	4222172
Drainage with pressurised air C3 or C5 cooling*	4222768
Standard Handshower	4222174
Heavy Duty Handshower	4222176
Reel-in Handshower	4222178
Wireless HACCP Transmitter Tempnet	4222186
EasyRun -Programming, 3 programs + wash program	4222182
EasyProg -Programming, 99 programs	4222184

\*Drainage with pressurised air saves water in ice water circulation.



*Automatic food water filling: adjustable customer specific bypass of water before filling for food production, water filling and measuring without supervision, manual filling with push button litres continuously on display. Even while tilting.*

## Proveno, Viking, Culino factory options

Installed at the factory, suitable also for Viking and Culino kettles	Code
Draw off tap D1-std	4211972
Draw off valve connection D2 SMS63 (delivered plugged)*	4222135
Arc valve CIP D2 SMS63 TC/ SMS51 male end	4222747
Butterfly valve with spout D2 SMS63 TC	4215858
Adapter for pump hose D2 SMS63 TC/ SMS51 male end	4222764
Heavy Duty mixer 150 L	4215823
Heavy Duty mixer 200 L	4215720
Heavy Duty mixer 300 L	4215814

\*for 80-400 litre kettles.

Valve connection drawing p. 141.



Standard hand shower



Heavy duty hand shower



Reel-in hand shower



Draw off tap D1-std



Draw off valve connection D2 SMS63 TC (delivered plugged)



Arc valve CIP D2 SMS63 TC/ SMS51 male end



Butterfly valve with spout D2 SMS63 TC



Adapter for pump hose D2 SMS63 TC/ SMS 51 male end

# METOS KETTLE ACCESSORIES

Accessories	Proveno	Viking Culino
Strainer plate 40-60	4222196	4211517
Strainer plate 80-100	4222198	4211524
Strainer plate 150-200	4222200	4211997
Strainer plate 300-400	4222202	4212013
Strainer platen extension 300-400	4222204	4212006
Pouring adapter 150-200	4222206	4212743
Pouring adapter 300-400	4222208	4212768
Whipping grid 40-60	4211203	4211203
Whipping grid 80-100	4211193	4211193
Whipping grid 150-200	4211186	4211186
Whipping grid 300	4211179	4211179
Whipping grid 400	4215872	4215872
Evaporation lid 80-100 L	—	4215873
Evaporation lid 150-200 L	—	4215874
Evaporation lid 300-400 L	—	4215875

Heavy Duty Mixing tool retrofit	Code
Heavy Duty Mixing tool 150 L	4215822
Heavy Duty Mixing tool 200 L	4215719
Heavy Duty Mixing tool 300 L	4215721
Heavy Duty Mixing tool 400 L	4215868

Kettle cleaning	Code
Cleaning tool 60 L	4222728
Cleaning tool 80 L	4222729
Cleaning tool 100 L	4222730
Cleaning tool 150 L	4222731
Cleaning tool 200 L	4222732
Cleaning tool 300 L	4222733
Cleaning tool 400 L	4222734
Cleaning brush	4000028
Scraper	4000029

Accessories	Proveno	Viking Culino
Measurement stick 40	4222212	4211316
Measurement stick 60	4222214	4211309
Measurement stick 80	4222216	4211281
Measurement stick 100	4222218	4211274
Measurement stick 150	4222220	4211267
Measurement stick 200	4222222	4211235
Measurement stick 300	4222224	4211228
Measurement stick 400	4222226	4215920

Accessories	Code
Potato stick Soft 670	4000030
Ergo dispensing scoop	4252305
Pouring support	4000012
Exhibition stand	4212359

### Upon request:

Sous Vide kit for Proveno 80-200 L

Hand mixer kit available for Proveno 40-100L kettle

Trolleys	Code
Multipurpose trolley MPT-450, GN1/1	4554132
Mixer tool holder to MPT-450 trolley	4215990
Draining aid to MPT-450 trolley	4215993
Multipurpose trolley MPT-2/450, GN2/1	4554133
Mixer tool wash trolley MWT	4554560
Mixer tool wash trolley MWT2 for 2 tools	4554562
Kettle accessory trolley	4554564



Strainer plate

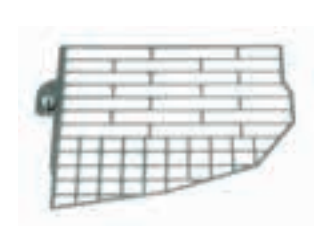

Whipping grid



Strainer plate extension  
for 300-400 litre kettles



Pouring adapter



Evaporation lid



Heavy duty tool



Cleaning tool is attached  
to the mixing tool



Cleaning brush



Scraper

# METOS KETTLE ACCESSORIES



Potato stick



Dispensing scoop



Measurement stick



Pouring support



Sous Vide basket and Sous Vide tool



Hand mixer kit



Multipurpose trolley MPT-450



Mixer tool holder for MPT-450



Draining aid for MPT-450



Multipurpose trolley MPT-2/450



Kettle accessory trolley



Mixer tool wash trolley MWT

# Metos Proveno Climatic – kettle with overwhelming chilling mixer tool

**Metos Proveno Climatic combi-kettle** with an integrated chilling Climatic mixer tool. Kettle is ready for icewater chilling system that cools even large volumes of liquid or semi-liquid food safely and fast, beating all existing chilling norms. Icewater circulates in the kettle's steam jacket and also in a special Climatic mixing tool cooling down your food extremely fast down to +3°C. Icewater system is ideal for large cook&chill units and customers who need to chill large volumes of food down to +3°C storing temperatures.



Metos Proveno Climatic kettle delivery includes icewater and pressurised air connections. Lift for mixing tool and handshower are options.

**50 % faster cooling!**



**Patented**

*With Climatic mixing tool you can beat all chilling norms by far.*

**Metos Proveno Climatic  
200 liters Bolognese sauce**

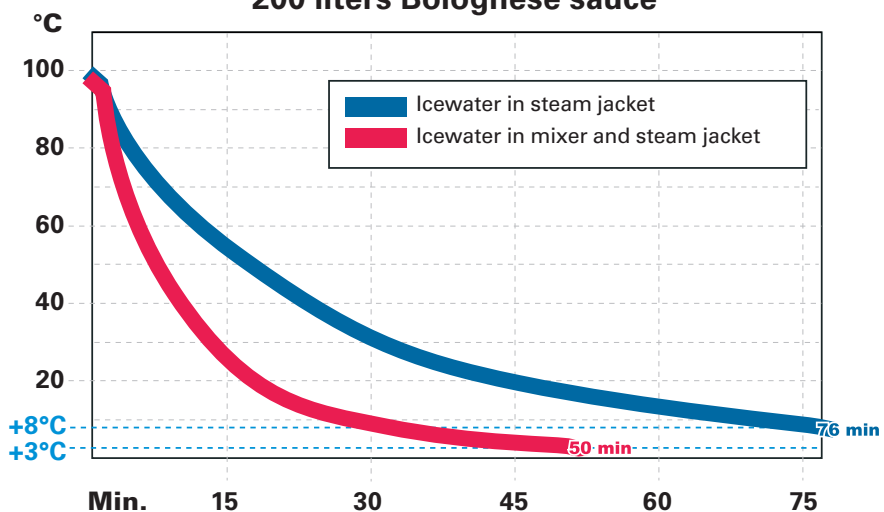

# METOS PROVENO CLIMATIC



Metos Proveno Climatic	Code	Measure mm	Electric connection
Metos Proveno Climatic 100E	4222754	1304x1230x1000/1535*	400V 3N~ 20,75 kW 40A
Metos Proveno Climatic 150E	4222755	1510x1170x1000/1535*	400V 3N~ 25,5 kW 50A
Metos Proveno Climatic 200E	4222756	1510x1170x1000/1535*	400V 3N~ 35,5 kW 63A
Metos Proveno Climatic 300E	4222757	1710x1300x1000/1535*	400V 3N~ 49,5 kW 100A

Also steam models available.

\*control pillar/control panel

Icewater circulates in the kettle's steam jacket and a special Climatic mixing tool.

Installation drawing p. 140.

Standard mixing tool with detachable scrapers is an accessory.

## Standard:

- High tilting (600 mm)
- Chilling Climatic mixer tool
- Chilling C3 Climatic
- Lift off safety grid lid
- Food temperature control
- Multifunctional timer
- Mixing when tilting
- Water add when tilting
- Tilting withdraw and other custom specific parameters
- USB connection
- Energy optimising connection
- HACCP facility
- Energy consumption measuring
- Measurement stick
- Pressurised air\*

Factory order options	Code
Lift for Climatic mixer tool	4222749
Food Water Automatics	4222180
Standard Handshower	4222174
Heavy Duty Handshower	4222176
Reel-in Handshower	4222178
Wireless HACCP Transmitter Tempnet	4222186
EasyRun -Programming, 3 programs + wash	4222182
EasyProg -Programming, 99 programs	4222184

Installation frame kits for single kettle	Code
Surface installation frame	4222748
Sub-surface inst. frame	4222700

Strainer plate	Code
Strainer plate 100 Climatic	4222751
Strainer plate 150-200 Climatic	4222752
Strainer plate 300 Climatic	4222202
Strainer plate extension 300 Climatic	4222753

Standard mixing tool	Code
Mixing tool with scrapers 100	4215158
Mixing tool with scrapers 150	4215167
Mixing tool with scrapers 200	4215160
Mixing tool with scrapers 300	4215161

\*Metos Proveno Climatic is to be connected to pressurised air. After cooling the kettle jacket and the mixing tool are emptied with pressurised air.

## Metos Culino & Culino Combi



**Metos Culino and Culino Combi kettles** are reliable and safe choices for every professional kitchen's food production. A set of versatile functions make kitchen work even easier. A lot of labor time can be saved when there is one appliance for cooking, mixing and optional chilling. The integrated bottom mixer makes the Culino Combi kettle a welcome, flexible tool for all chefs in today's busy kitchens.

The electronic temperature control and display ensures accurate settings for the chef. Smooth electric tilting makes decanting easy and a fully insulated kettle body saves your kitchen energy while improving workplace safety.

Kettle features an integrated mixer for versatile food production of both hot and cold food. When equipped with optional cooling, the Culino Combi makes a complete process from start to finish. Cook, Mix & Chill! Metos Culino Combi adapts to your needs and enables you to develop your food production programs.

The bottom mixer is easy to use. It can gently mix soups, aggressively mash potatoes or root vegetables, crush and cook minced meat or even make a bread dough. Automatic mixing programs make many dishes a 1 button operation, while maintaining the flexibility needed for any recipe your chef may have.



*The easy to read control panel has large press buttons and ergonomic positioning.*



A lift off safety grid enables continuous view into kettle and adding of ingredients, water and spices while the mixer is activated.



One mixing tool with lift off scrapers for all kind of mixing. Light but strong, unique shape.

# METOS CULINO AND CULINO COMBI KETTLES

*Culino Combi has an integrated bottom mixer. The mixer tool is securely in place also when tilting. The mixer tool is easy to remove thanks to the clean lifting handle. Removable scrapers. All parts are dishwasher proof.*

*The Culino can be connected to the control pillar of another Culino, Proveno or Viking combi kettle to save space.*

*Electric tilting is ergonomic and safe. 300-400 l kettles have hydraulic tilting.*

*Robust stainless steel lid. Solid lid is standard, a safety grid lid is optional. Safety grid lid enables adding of ingredients, water and spices while the mixer is activated. All parts are removable and dishwasher proof.*

*Optional Integrated hand shower*

*Four automated mixing programs*

*Ergonomically raised control panel with clear push buttons for each function. Automatic timer and water functions are optional*



## TempNet®

- Automatic
- Wireless
- Real-time
- Easy to install
- Device independent
- Modular
- Accessed via Internet
- 24/7 maintenance
- Incorruptible
- Alarm messages sent as SMS
- Extendable

Culino and Culino Combi can be equipped with a choice of two hand showers.

Culino Combi kneads doughs in a matter of minutes.

**Metos TempNet, see p. 46.**

# Metos Culino

- construction stainless steel, inner surface acid proof stainless steel
- stepless temperature control, max. +120 °C
- max. working pressure in steam jacket 1,0 bar
- electrical tilting
- fully isolated kettle bowl

**Standard equipment**

- separate solid lid 40-100 L
- 150-400L with hinged solid lid
- water faucet
- measuring stick
- hook for accessories on left and right pillar (single kettle)



CULINO, electric	Code	Dimensions mm	Electric connection
Culino 40E	4215202	1047x620x1020	400V3N~ 12 kW 20A
Culino 60E	4215203	1047x620x1020	400V3N~ 12 kW 20A
Culino 80E	4215204	1154x690x1020	400V3N~ 16 kW 25A
Culino 100E	4215205	1154x690x1020	400V3N~ 16 kW 25A
Culino 150E	4215206	1360x940x1040	400V3N~ 20 kW 32A
Culino 200E	4215207	1360x940x1040	400V3N~ 30 kW 50A
Culino 300E	4215243	1560x1165x1040	400V3N~ 40 kW 63A
Culino 400E	4215722	1560x1165x1220	400V3N~ 57,6 kW 83A

CULINO, steam	Code	Dimensions mm	Electric connection	Steam cons.
Culino 40S	4215209	1047x730x902/1710	230V1N~ 0,3 kW 16A	12 kg/h
Culino 60S	4215210	1047x730x902/1710	230V1N~ 0,3 kW 16A	18 kg/h
Culino 80S	4215211	1154x785x902/1800	230V1N~ 0,3 kW 16A	24 kg/h
Culino 100S	4215212	1154x785x902/1800	230V1N~ 0,3 kW 16A	30 kg/h
Culino 150S	4215213	1360x945x902/1980	230V1N~ 0,3 kW 16A	45 kg/h
Culino 200S	4215214	1360x945x902/1980	230V1N~ 0,3 kW 16A	60 kg/h
Culino 300S	4215244	1560x1165x902/2100	400V3N~ 0,5 kW 16A	90 kg/h
Culino 400S	4215547	1560x1165x1050/2100	400V3N~ 0,5 kW 16A	120kg/h

Installation frame kits for single kettle	Code
Surface installation frame, 40-100	4215837
Surface installation frame, 150-400	4215839
Sub-surface installation frame, 40-100	4215838
Sub-surface installation frame, 150-400	4215840

Installation frame kits for kettle group	Code
Surface installation frame, 40-100	4215845
Surface installation frame, 150-400	4215843
Sub-surface installation frame, 40-100	4215846
Sub-surface installation frame, 150-400	4215844

Factory options	Code
Automatic water filling	4215245
Handshower S1	4215246
Heavy duty handshower S2	4222176
Timer	4215248
Manual cooling with tap water C1 <sup>1)</sup>	4215249
Automatic cooling with tap water C2 <sup>2)</sup>	4215855
HACCP facilities	4213095
HACCP connection package	4007060

Accessories	Code
Strainer plate 40-60	4211517
Strainer plate 80-100	4211524
Strainer plate 150-200	4211997
Strainer plate 300-400	4212013
Strainer plate extension 300-400	4212006
Pouring adapter 150-200	4212743
Pouring adapter 300-400	4212768
Food temperature display	4215379

Installation drawing p. 142-143.

1) requires handshower  
2) includes HACCP facilities and food temperature control

For valves and accessories see pages 17-19.  
For HACCP see Metos TempNet page 46.



# Metos Culino Combi

- construction stainless steel, inner surface acid proof stainless steel
- stepless temperature control, max. +120 °C
- max. working pressure in steam jacket 1,0 bar
- electrical tilting
- fully isolated kettle bowl
- integrated mixer: stepless mixing speed control (20-110 rpm)
- four mixing programmes
- autoreverse mixing
- machine washable mixing tool with removable scrapers

### Standard equipment

- safety grid lid lid
- water faucet
- measuring stick
- hook for accessories on left and right pillar (single kettle)



CULINO COMBI, electric	Code	Dimensions mm	Electric connection
Culino Combi 40E	4215216	1047x620x1020	400V3N~ 12,75 kW 25A
Culino Combi 60E	4215217	1047x620x1020	400V3N~ 12,75 kW 25A
Culino Combi 80E	4215218	1154x690x1020	400V3N~ 16,75 kW 32A
Culino Combi 100E	4215219	1154x690x1020	400V3N~ 16,75 kW 32A
Culino Combi 150E	4215220	1360x940x1040	400V3N~ 21,5 kW 40A
Culino Combi 200E	4215221	1360x940x1040	400V3N~ 31,5 kW 69A
Culino Combi 300E	4215242	1560x1165x1040	400V3N~ 41,5 kW 80A
Culino Combi 400E	4215723	1560x1165x1220	400V3N~ 59,8 kW 100A

CULINO COMBI, steam	Code	Dimensions mm	Electric connection	Steam
Culino Combi 40S	4215223	1047x730x902/1710	230V1N~ 1,0 kW 16A	12 kg/h
Culino Combi 60S	4215224	1047x730x902/1710	230V1N~ 1,0 kW 16A	18 kg/h
Culino Combi 80S	4215225	1154x785x902/1800	230V1N~ 1,0 kW 16A	24 kg/h
Culino Combi 100S	4215226	1154x785x902/1800	230V1N~ 1,0 kW 16A	30 kg/h
Culino Combi 150S	4215227	1360x945x902/1980	230V1N~ 1,8 kW 16A	45 kg/h
Culino Combi 200S	4215228	1360x945x902/1980	230V1N~ 1,8 kW 16A	60 kg/h
Culino Combi 300S	4215229	1560x1165x902/2100	400V3N~ 2,0 kW 16A	90 kg/h
Culino Combi 400S	4215824	1560x1165x1050/2100	400V3N~ 2,7 kW 16A	120 kg/h

Installation frame kits for single kettle	Code
Surface installation frame, 40-100	4215837
Surface installation frame, 150-400	4215839
Sub-surface installation frame, 40-100	4215838
Sub-surface installation frame, 150-400	4215840

Installation frame kits for kettle group	Code
Surface installation frame, 40-100	4215845
Surface installation frame, 150-400	4215843
Sub-surface installation frame, 40-100	4215846
Sub-surface installation frame, 150-400	4215844

Factory options	Code
Lid with safety grid 40-60	4215234
Lid with safety grid 80-100	4215235
Lid with safety grid 150-200	4215236
Lid with safety grid 300-400	4215237
Automatic water filling	4215245
Handshower S1	4215246
Heavy duty handshower S2	4222176
Timer	4215248
Manual cooling with tap water C1 <sup>1)</sup>	4215249
Automatic cooling with tap water C2 <sup>2)</sup>	4215855

Food temperature control <sup>3)</sup>	4215856
HACCP facilities	4213095
HACCP connection package	4007060

Accessories	Code
Strainer plate 40-60	4211517
Strainer plate 80-100	4211524
Strainer plate 150-200	4211997
Strainer plate 300-400	4212013
Strainer plate extension 300-400	4212006
Pouring adapter 150-200	4212743
Pouring adapter 300-400	4212768
Whipping grid 40-60	4211203
Whipping grid 80-100	4211193
Whipping grid 150-200	4211186
Whipping grid 300	4211179
Whipping grid 400	4215872
Food temperature display	4215379

- 1) requires handshower
- 2) includes HACCP facilities and food temperature control
- 3) includes HACCP facilities

For valves and accessories see pages 17-19.  
For HACCP see Metos TempNet page 46.

## TempNet®

- Automatic
- Wireless
- Real-time
- Easy to install
- Devise independent
- Modular
- Accessed via Internet
- 24/7 maintenance
- Incorruptible
- Alarm messages sent as SMS
- Extendable

Metos TempNet, see p. 46.

Installation drawing p. 142-143.

## METOS VIKING

**Metos Viking kettle** is an efficient and userfriendly basic kettle for all types of professional kitchens. Thanks to the large steam jacket up to the kettle's upper rim, soups, sauces and many other products will be cooked faster and electrical tilting makes unloading easy. Viking-kettles can be installed in line without a support pillar in the middle which saves space in a kitchen.

- construction stainless steel, inner surface acid proof stainless steel (EN 1.4432)
- stepless temperature control, max. +120 °C
- max. working pressure in steam jacket 1,0 bar
- electrical tilting / hydraulic tilting (300-400L)

### Standard equipment

- separate lid (150-400 l with hinged lid)
- water faucet (cold water)
- measuring stick
- hook for accessories on left and right pillar (single kettle)



## METOS VIKING COMBI

**Metos Viking Combi** is a basic cooking kettle with powerful integrated mixing device for versatile and professional food production. With the mixer, many dishes can be cooked from start to finish in one unit without any food transfer. Mixing assists heat transfer and food is cooked faster and more evenly. Hard manual mixing work is a thing of a past. Unique mixing features enable easy cooking of minced meat and mashing of potatoes for purées.

- construction stainless steel, inner surface acid proof stainless steel (EN 1.4432)
- stepless temperature control, max. +120 °C
- max. working pressure in steam jacket 1,0 bar
- electrical tilting
- integrated mixer: stepless mixing speed control (15-110 rpm), two mixing programmes (gentle mixing, hard mixing)
- autoreverse mixing
- mixing tool with removable scrapers

### Standard equipment

- safety grid lid lid
- water faucet (cold water)
- measuring stick
- hook for accessories on left and right pillar (single kettle)



**TempNet®**

- Automatic
- Wireless
- Real-time
- Easy to install
- Devises independent
- Modular
- Accessed via Internet
- 24/7 maintenance
- Incorruptible
- Alarm messages sent as SMS
- Extendable

Metos TempNet, see p. 46

# METOS VIKING AND VIKING COMBI



A hinged lid is standard in 150-400 litre Viking-kettles and available as an option in smaller kettles.



Viking Combi kettle is pictured with a safety grid lid.

Viking electric	Code	Dimensions mm	Electric connection
Viking 40E	4215340	1047x750x1020	400V3N~ 9 kW 16A
Viking 60E	4215341	1047x750x1020	400V3N~ 10,5 kW 16A
Viking 80E	4215343	1154x750x1020	400V3N~ 12 kW 20A
Viking 100E	4215344	1154x805x1020	400V3N~ 16 kW 25A
Viking 150E	4215345	1360x940x1040	400V3N~ 20 kW 32A
Viking 200E	4215346	1360x940x1040	400V3N~ 30 kW 50A
Viking 300E	4215850	1560x1165x1220	400V3N~ 40 kW 63A
Viking 400E	4215851	1560x1165x1220	400V3N~ 57,6 kW 100A

Viking steam	Code	Dimensions mm	Electric connection	Steam cons.
Viking 40S	4215531	1047x650x1020	230V1N~ 0,3 kW 16A	12 kg/h
Viking 60S	4215532	1047x650x1020	230V1N~ 0,3 kW 16A	18 kg/h
Viking 80S	4215533	1154x750x1020	230V1N~ 0,3 kW 16A	24 kg/h
Viking 100S	4215534	1154x750x1020	230V1N~ 0,3 kW 16A	30 kg/h
Viking 150S	4215535	1360x920x1040	230V1N~ 0,3 kW 16A	45 kg/h
Viking 200S	4215537	1360x920x1040	230V1N~ 0,3 kW 16A	60 kg/h
Viking 300S	4215522	1560x1165x1040	400V3N~ 0,5 kW 16A	90 kg/h
Viking 400S	4215827	1560x1165x1220	400V3N~ 0,5 kW 16A	120 kg/h

Viking Combi electric	Code	Dimensions mm	Electric connection
Viking Combi 40E	4215348	1047x750x1020	400V3N~ 9,75 kW 25A
Viking Combi 60E	4215349	1047x750x1020	400V3N~ 11,25 kW 25A
Viking Combi 80E	4215350	1154x750x1020	400V3N~ 12,75 kW 32A
Viking Combi 100E	4215351	1154x805x1020	400V3N~ 16,75 kW 35A
Viking Combi 150E	4215352	1360x940x1040	400V3N~ 21,5 kW 50A
Viking Combi 200E	4215353	1360x940x1040	400V3N~ 31,5 kW 63A
Viking Combi 300E	4215354	1560x1165x1220	400V3N~ 41,5 kW 80A
Viking Combi 400E	4215852	1560x1165x1220	400V3N~ 59,8 kW 100A

Viking Combi steam	Code	Dimensions mm	Electric connection	Steam cons.
Viking Combi 40S	4215539	1047x730x1020	230V1N~ 1,0 kW 16A	12 kg/h
Viking Combi 60S	4215540	1047x730x1020	230V1N~ 1,0 kW 16A	18 kg/h
Viking Combi 80S	4215541	1154x780x1020	230V1N~ 1,0 kW 16A	24 kg/h
Viking Combi 100S	4215542	1154x780x1020	230V1N~ 1,0 kW 16A	30 kg/h
Viking Combi 150S	4215544	1360x940x1040	230V1N~ 1,8 kW 16A	45 kg/h
Viking Combi 200S	4215545	1360x940x1040	230V1N~ 1,8 kW 16A	60 kg/h
Viking Combi 300S	4215546	1560x1165x1040	400V3N~ 2,0 kW 16A	90 kg/h
Viking Combi 400S	4215828	1560x1165x1220	400V3N~ 2,7 kW 16A	120 kg/h

Installation drawing p. 142-143.

Factory options	Code
Handshower S1	4215246
Heavy duty handshower S2	4222176
Automatic food water filling	4215825
Food temperature display <sup>1)</sup>	4215379
Manual cooling with tap water C1 <sup>2)</sup>	4215249
HACCP facilities	4213095
HACCP connection package	4007060

Factory option for Viking	Code
Hinged lid 40-60	4215355
Hinged lid 80-100	4215356

Factory option for Viking Combi	Code
Lid with safety grid 40-60	4215234
Lid with safety grid 80-100	4215235
Lid with safety grid 150-200	4215236
Lid with safety grid 300-400	4215237

Accessories	Code
Strainer plate 40-60	4211517
Strainer plate 80-100	4211524
Strainer plate 150-200	4211997
Strainer plate 300-400	4212013
Strainer plate extension 300-400	4212006
Pouring adapter 150-200	4212743
Pouring adapter 300-400	4212768

Accessory for Viking Combi	Code
Whipping grid 40-60	4211203
Whipping grid 80-100	4211193
Whipping grid 150-200	4211186
Whipping grid 300	4211179
Whipping grid 400	4215872

Installation frame kits for single kettle	Code
Surface installation frame, 40-100	4215837
Surface installation frame, 150-400	4215839
Sub-surface inst. frame, 40-100	4215838
Sub-surface inst. frame, 150-400	4215840

Installation frame kits for kettle groups	Code
Surface installation frame, 40-100	4215845
Surface installation frame, 150-400	4215843
Sub-surface inst. frame, 40-100	4215846
Sub-surface inst. frame, 150-400	4215844

For valves and accessories see pages 17-19.

For HACCP see Metos TempNet page 46.

- 1) includes HACCP facilities
- 2) requires handshower

# METOS MENU BOILING AND BRAISING PAN

**Metos Menu** boiling and braising pan is an efficient and robust kettle for cooking and braising. Menu is simple and easy to use. Menu net volume is 40 litres, the maximum liquid level is indicated in the bowl.

The unit is a single jacket vessel capable of 250°C bottom heating. Browning onions and meats is now possible, given its 250°C temperature rating.

Easy electrical tilting with a button. A single grip mixing tap on the left pillar for hot and cold water.

Cooking can be controlled with a buzzer timer up to two hours or continuous (factory option).

Ergonomic work spaces on top of the pillars for example for easy emptying of milk containers.



- construction stainless steel
- maximum temperature +250°C
- electrical tilting

#### Standard equipment

- separate stainless steel lid
- water faucet (cold and warm water)
- buzzer timer up to 2 hours or continuous
- hook for accessories
- maximum load mark
- ergonomic workspace on top pillar

#### Options

- handshower
- installation frames (compulsory)
- wheel base with lockable wheels



Metos	Code	Volume l	Dimensions mm	Electric connection
Menu 40	4222350	40	1010x602x1058	400V3N~ 12 kW 16A

Installation frames	Code
Surface installation frame	3755367
Sub-surface installation frame	3755368

Factory options	Code
Hand shower	4222360
Wheel base	4222370

Accessories	Code
Measurement stick	4222372



# METOS FUTURA MARVEL PRESSURE STEAMERS



Metos Futura Marvel SE14. Both electrically and direct steam heated models available.

**Metos Futura Marvel** defrosts, reheats and cooks food, even products requiring cautious handling. Thanks to Futura Marvel's speed and efficiency you can prepare a meal just before serving it, thus ensuring its freshness. Gentle steam cooking retains the texture, nutrients and colour of the products. Futura Marvel is useful in situations, where the amount of food needed changes rapidly and unexpectedly. Additional portions made of various ingredients can be prepared quickly, as Futura Marvel needs no preheating. Many dishes can be cooked simultaneously without the flavours transferring from one food to another.



● Adjustable steam cooking 65...95°C

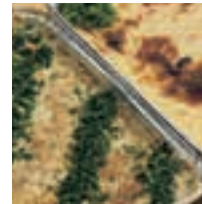

● Pressure cooking 1,0 bar (120°C)



● Pressure cooking 0,5 bar (110°C)



● Steam cooking 100°C



Variable temperature range makes Futura Marvel a versatile appliance: pressure cooking, cooking in steam, variable steam, sous vide, regenerating, defrosting etc. Futura Marvel twice as fast as than any combi steamer. Suitable for most common GN containers (1/1, 2/3, 1/2, 1/3).

**Construction and scope of delivery:** Ergonomic and solid structure in stainless steel throughout. Half minute timer 1-99 min (time left), steam condenser, safety valve, back pressure valve and mud separator. All maintenance can easily be done at the front. Thanks to the adjustable feet the installation even on an inclined floor is easy. Delivery of SE/SS14 includes 2 x GN 1/1-65 R containers, and SE/SS24 includes 4 x GN 1/1-65 R containers. Temperature ranges: Adjustable cooking 65...95°C, cooking 100°C. Pressure cooking 0,5 bar, pressure cooking 1,0 bar. Max. working pressure 1,0 bar.

- Cooking in pressurised steam is 2-5 times faster than cooking in water or pressureless steam
- Due to its speed, Futura Marvel's actual cooking capacity is up to five times higher than that of its chamber capacity
- Easy to use; electronically controlled operation, an easy-to-use control panel, one handed operation
- Easy to clean; food cannot be burnt. The chamber is fitted with removable GN guide rails and trough at the front.
- Correct working height
- The door is safe, fast and easy to open and close using one hand

# METOS FUTURA MARVEL PRESSURE STEAMERS

Using Metos Futura Marvel you can defrost, reheat and cook food, even products requiring cautious handling.

Standard times	0 bar	0,5 bar	1 bar
Potato	40 min	20 - 25 min	15 - 20 min
Broccoli	10 - 12 min	5 - 6 min	3 - 4 min
Peas(frozen)	4 - 5 min	2 - 3 min	1 - 2 min
Chicken à 1 kg	150 min	80 min	
Cold meat in cubes	90 min	30 - 40 min	
Cooked fish à 1 kg	20 min	15 min	10 - 15 min
Fish terrine	35 min	25 min	20 min
Spaghetti	15 - 16 min	10 min	8 min
Rice	15 - 16 min	12 min	8 min
Caramel custard		25 min	
Cabbage casserole	75 min	35 min	20 min
Liver casserole (regenerating)	90 min	45 - 50 min	35 min
Beef stroganoff (regenerating)	65 min	35 min	20 min

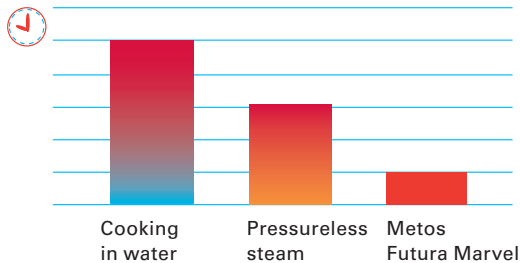

With the Metos Futura Marvel you can swiftly respond to changing demand and reduce losses. You can simultaneously make different dishes, since tastes and aromas will not transfer from one food to another.



The two-chambered Metos Futura Marvel SE 24 steamer takes 8 x GN 1/1-65 mm containers or 6 x GN 1/1-100 mm containers. An extra storage compartment is located in the base.



The GN guide rails are removable and machine washable. The rounded, seamless structure of the chamber makes it easy to clean. There is a waste water pipe in the chamber.



Water dripping from the door and containers is collected in the trap. It is easy to take out and clean separately in a dishwasher.



The single-chambered Metos Futura Marvel SE 14 pressure steamer takes 4 x GN 1/1-65 mm containers or 3 x GN1/1-100 mm containers.



Several extra portions can be prepared quickly. Flavours will not intermingle. Cooking in pressurised steam is 2-5 times faster than in water or pressureless steam.

Metos	Code	Capacity	Dimensions mm	Electric connection
Futura SE 14	3472322	4 x GN 1/1-65 mm	720x795x1430	400V 3N~ 24 kW 50A
Futura SE 24	3460871	8 x GN 1/1-65 mm	1200x795x1430	400V 3N~ 36 kW 63A
<b>Direct steam heated models</b>				
Futura SS 14	3472354	4 x GN 1/1-65 mm	720x795x1430	230V 1N~ 0,1 kW 16A
Futura SS 24	3472361	8 x GN 1/1-65 mm	1200x795x1430	230V 1N~ 0,1 kW 16A

Installation drawing p. 144.

## METOS CHEF CONVECTION AND ROASTING-BAKING OVENS

---



Metos Chef convection ovens for cooking and baking



Metos Chef roasting ovens



Metos Chef proving cabinets

**Metos Chef** is a first-class oven and proving cabinet series for demanding professional users. All Chef ovens produce impressive and uniform baking results. Chef ovens are easy to install, use, service and maintain. Design a productive combination for your own particular needs.



Oven group Metos Chef 240/220/200





# METOS CHEF CONVECTION AND ROASTING-BAKING OVENS



A large double-glazed door can be cleaned between glasses. Air circulating between the panes reduces the surface temperature of the door. The door is opened by an insulated single-grip handle.



The roasting and baking oven has an over-flow tray that can be pulled out to facilitate cleaning, and it can also be used for humidifying. An optional storing heartstone can be installed on top of it.



Cleaning is easy due to detachable rails and a mirror-polished, round-cornered chamber.



The oven's operating panel is clear. Switches are strong and easy to operate. A powerful fan and the round-cornered oven chamber guarantee a good baking result.



Electrical as well as water and drain connections are situated at the back of the appliance, as is an oven-chamber steam outlet. These facilitate installation and allow stacking of appliances on top of one another.



A single appliance can be installed on a table. A group of 1-3 appliances is installed on a stand according to choice. Stands are optional.



The oven chamber has effective lighting and the thermostat detector is protected. Convection ovens are available in three sizes: for GN1/1, GN2/1 and bakery plate size 450x600 mm. Oven models are Chef 40, Chef 240 and Chef 50 respectively.



## METOS CHEF 50T AND 40T CONVECTION OVENS



Chef 50 bakery plates 450x600 mm



Chef 40 GN1/1

**Metos Chef 50T and Chef 40T** ovens are built into the operational BakeOff baking point for shops, cafés or industrial kitchens.

- equipped with humidifier and large fan
- can be installed separately or assembled in a group

**Metos Chef 50T capacity:**

- guide rails for 4 bakery plates, size 450x600 mm, standard
- guide distance 90 mm

**Accessories**

- stand for one unit with plate rack and guide rails for 10 plates

**Metos Chef 40T capacity:**

- in baking 5 x GN1/1 plates, guide distance 80 mm

**Accessories**

- optional guide rails for 3 x GN1/1 plates for cooking, distance 125 mm
- stands for one, two and three units



Convection ovens Chef 50T and 40T Code		Capacity	Dimensions mm	Electric connection
Chef 50T convection oven	3754987	for bakery plates 400x600 or 450x600	800x900x540	400V 3N~ 10.5 kW 16A
Chef 50T oven group	3754990	2x Chef 50T + stand 4570979	800x900x1720	400V 3N~ 21 kW 32A
Chef 40T convection oven	3754988	Bake-off/baking 5xGN 1/1	800x700x540	400V 3N~ 10.5 kW 16A
Chef 40T guide rails	3672071	for cooking 3xGN1/1		
<b>Stands</b>				
Chef 50T stand	4570509	For one unit, plate rack and guide rails for 10 plates		
Chef 50T stand 2U	4570979	For two units, guide rails for 7 plates	790x680x1000	
Chef 40T stand 1U	4570925	For one unit	775x560x1000	
Chef 40T stand 2U	4570932	For two units (GN/1)	775x560x660	
Chef 40T stand 3U	4570957	For three units (GN/1)	775x560x20	

## METOS CHEF 240 CONVECTION OVEN



Chef 240 GN2/1

**Metos Chef 240** is suitable for all cooking and baking.

- equipped with humidifier and large fan
- can be installed separately or assembled in a group

**Metos Chef 240 capacity:**

- cooking 2 x GN 2/1 or 4 x GN 1/1, distance 125 mm

**Accessories**

- guide rails for baking 3 x GN 2/1 or 6 x GN 1/1, distance 100 mm
- stands for one, two and three units

Convection oven Chef 240		Code	Capacity	Dimensions mm	Electric connection
Chef 240 convection oven	3751958	2x GN2/1 or 4xGN1/1		800x800x460	400V 3N~ 7,6 kW 16A
Chef 240 oven group 2U	3751978	2x Chef 240 + stand Metos 2928		800x800x1600	400V 3N~ 15,2 kW 22A
Chef 240 oven group 2U+Chef 200	3751986	2x Chef 240 + Chef 200 + stand Metos 2908		800x800x1620	400V 3N~ 16,1 kW 26A
Chef 240 guide rails	3753098	for baking 3xGN 2/1 or 6xGN 1/1			
<b>Stands</b>					
Stand Metos 2948	3466135	Chef 200, 220, 240 (GN2/1) for one unit		790x710x900	
Stand Metos 2928	3293475	Chef 200, 220, 240 (GN2/1) for two units		790x710x660	
Stand Metos 2908	3293482	Chef 200, 220, 240 (GN2/1) for three units		790x710x200	
Stand 2U	4570977	Chef 200, 220, 240 for two units		790x710x660	guide rails for 10 plates

## METOS CHEF 220 ROASTING OVEN



Chef 220 GN2/1

**Metos Chef 220** roasting oven is an effective standard oven for industrial kitchens and it is uniformly successful with all kinds of traditional cooking and baking. An optional heat storage stone evens out oven temperature and improves baking results.

- robust standard oven
- can be installed separately or assembled in a group

**Metos Chef 220 capacity:**

- in baking 1 x GN 2/1 or 2 x GN 1/1
- oven with upper and lower guide rails

**Accessories**

- optional heat storage stone
- stands for one, two and three units

Roasting oven Chef 220	Code	Capacity	Dimensions mm	Electric connection
Chef 220 roasting oven	3751969	1x GN 2/1 or 2xGN 1/1	800x800x460	400V3N~4,7 kW 10A
Chef 220 oven group 2U	3751976	2x Chef 220 + stand Metos 2928	800x800x1640	400V3N~9,4kW 20A
Chef 220 oven group 3U	3751982	3x Chef 220 + stand Metos 2908	800x800x1640	400V3N~14,1kW 20A
Chef 220 oven group 2U+Chef 200	3751984	2x Chef 220 + Chef 200 + stand Metos 2908	800x800x1640	400V3N~10,3kW 20A
Chef 220 storing heartstone	3596744			
<b>Stands</b>				
Stand Metos 2948	3466135	Chef 200, 220, 240 (GN2/1) for one unit	790x710x900	
Stand Metos 2928	3293475	Chef 200, 220, 240 (GN2/1) for two units	790x710x660	
Stand Metos 2908	3293482	Chef 200, 220, 240 (GN2/1) for three units	790x710x200	

## METOS CHEF 200 PROVING CABINET



Chef 200 GN2/1

**Metos Chef 200** proving cabinet ensures uniform baking quality from start to finish. The proving cabinet can be assembled in a group with Chef ovens.

- for proving baking products
- equipped with humidifier and fan
- can be installed separately or assembled in a group

**Metos Chef 200 capacity:**

- 4 x GN 2/1 or 8 x GN 1/1 plates, distance 72 mm

**Accessories**

- optional guide rails for five 450x600 mm bakery plates, distance 73 mm

Proving cabinet	Code	Capacity	Dimensions mm	Electric connection
Chef 200 proving cabinet	3751975	4x GN2/1 or 8xGN 1/1	800x800x460	230V 1~0,9 kW 4A
Chef 200 guide rails	3595966	bakery plates 400x600 or 450x600		
<b>Stands</b>				
Stand Metos 2948	3466135	Chef 200, 220, 240 (GN2/1) for one unit	790x710x900	
Stand Metos 2928	3293475	Chef 200, 220, 240 (GN2/1) for two units	790x710x660	
Stand Metos 2908	3293482	Chef 200, 220, 240 (GN2/1) for three units	790x710x200	



Chef 50 bakery plate stand for one unit, plate rack and guide rails for 10 plates in the stand.



Chef 40 stand for one unit, plate rack and guide rails for 10 plates in the stand.



Stand 2928 for two units.

Installation drawing p. 145-146.

## METOS ARDOX S FLAT-TOP RANGES

**Metos Ardox S** is a chrome-surfaced flat-top stainless steel range with a choice of two, four or six 3,5 kW heating zones. The advantage of the flat-top range over a conventional iron plate range lies in its tempered chrome surfacing which reduces heat loss, cuts the kitchen's heat generation and saves energy. You can regulate the temperature of every cooking zone separately, either by using the stepless temperature control or by shifting pans between the cooking zones.

The edges around the range are the same height as the cooking zones. The six zone model has separate two and four section chrome-surfaced stainless cooking tops. You can also order optional side shelves which makes serving easier and allow you to shift pans conveniently over the edge of the range with no risk of tipping. The flat range top makes cleaning quick and easy, and there is even a gutter between the top and the edge to funnel boil-overs and cleaning water. There is also a splash and splatter profile at the back of the range to prevent food matter from getting behind the range.



Besides using the temperature control dial, you can regulate cooking temperature by shifting pans between the cooking zones. The flat chrome surfacing prevents heat radiation and thus saves energy.



### Always the right working height

Individual adjustment of the working height is easy for Metos Ardox S H range user. The Ardox is available with a stand with adjustable height. It is a safe and ergonomic for people of different length. The range can be adjusted so that it is always at the right height to avoid unnecessary stretching and uncomfortable working positions.

Make your work fun by using the adjustable Ardox S H range!

Metos Ardox S4 H with height-adjustable stand



## ARDOX S WITH SHELF

Open stand with shelf. At the rear edge of the stand there is a protective casing for the connection cable. The six zone range has two and four chrome surfaced cooking zones. The H models are with height adjustment, the working height can be ideally adjusted for every user. Adjustment range is 70 – 90 cm.

Ardox	Code	Cooking zones	Dimensions mm	Electric connection
S2	4210016	2 x 3,5 kW	500x800x900	400V 3N~7,0 kW
S4	4210023	4 x 3,5 kW	800x800x900	400V 3N~14,0 kW
S6	4210048	6 x 3,5 kW	1200x800x900	400V 3N~21,0 kW
S4 H	4210143	4 x 3,5 kW	800x800x900	400V 3N~ 14,1 kW
S6 H	4210168	6 x 3,5 kW	1200x800x900	400V 3N~ 21,1 kW



Metos Ardox S4/240 with Metos Chef 240 convection oven in the stand



Metos Ardox S2

## ARDOX S WITH OVEN

The stand of the S4/220 and S6/220 model is fitted with a Metos Chef 220 roasting-baking oven. The stand of the S4/240 and S6/240 model is fitted with a Metos Chef 240 convection oven.

Ardox	Code	Cooking zones	Dimensions mm	Electric connection
S4/220	3752018	4 x 3,5 kW	800x800x900	400V 3N~ 18,7 kW
S4/240	3752015	4 x 3,5 kW	800x800x900	400V 3N~ 21,5 kW
S6/220	3752019	6 x 3,5 kW	1200x800x900	400V 3N~ 25,7 kW
S6/240	3752017	6 x 3,5 kW	1200x800x900	400V 3N~ 28,5 kW

## ARDOX S WITH CABINET

The built-in cabinet or drawer protects dishes and utensils from getting dirty during cooking or cleaning. The cabinet has one shelf. Even the backmost utensils in the drawer can be easily reached. D is an abbreviation for a cabinet and B for a drawer. S4 D: a double door cabinet underneath. S4 B: a big drawer underneath. S6 D: a three-door cabinet underneath. S6 DB: a big drawer and a single door cabinet underneath.

Ardox	Code	Cooking zones	Dimensions mm	Electric connection
S4 D	4210104	4 x 3,5 kW	800x800x900	400V 3N~14 kW
S4 B	4210111	4 x 3,5 kW	800x800x900	400V 3N~14 kW
S6 D	4210129	6 x 3,5 kW	1200x800x900	400V 3N~21 kW
S6 DB	4210136	6 x 3,5 kW	1200x800x900	400V 3N~21 kW



Metos Ardox S6 DB with a cabinet and drawer (on the right)

## ARDOX S TABLETOP



Metos Ardox S Tabletop

Ardox S Tabletop serves as a flexible way of adding cooking capacity. The range has a hard chrome top and a gutter and drawer for boil-overs. Takes only 800 x 510 mm table top space.

Ardox	Code	Cooking zones	Dimensions mm	Electric connection
Tabletop	3753577	2 x 3.5 kW	800x510x190	400V 3N~7 kW

Also models with 4 and 6 cooking zones available.

Installation drawing p. 147.

# METOS ARDOX INDUCTION AND CERAMIC RANGES

**Metos Ardox I** is a freestanding full induction range. The cooking vessels are heated efficiently, quickly, safely and controllably with induction. Even over 90% of the energy used can be transferred to the cooking vessel. The range also reacts immediately to power regulation, making it very easy to find the desired power level.

Heating by induction is based on a magnetic field created between the cookware and the induction coil below the range surface. The top is electrically and magnetically passive, and it heats up just from the heat transferred to the cookware. The heat is not absorbed in the plates, only the vessel bottom and the food in the pot or container are heated. The electromagnetic field reacts instantly to the position of the heat selector generating really quick changes of temperature. The use of the induction range is very fast and also safe, since the top around the pot remains cold. Likewise, cleaning is easy, since food does not burn on the cold top. The pots used on an induction range must be of magnetising material, which can be tested with a small magnet; for instance copper, glass or aluminium bottom are not suitable.

**Metos Ardox C** is a classical glass ceramic range, where the cooking vessels are heated with an infrared radiant heat element. The Ardox C has large, square 4kW heating elements in the back and smaller 2.4kW round elements in the front. The benefits of the Ardox C over a cast iron range include near instantaneous up-warming, smaller amount of excess heat and easier maintenance. The Ardox C range can be completed with Metos Chef convection and baking oven.

**Metos Ardox IC** is a product concept that combines the benefits of induction to a reasonable price level and the possibility to carry on using old cookware that is not induction compatible. The Ardox IC has two induction cooking zones and two round infrared cooking zones

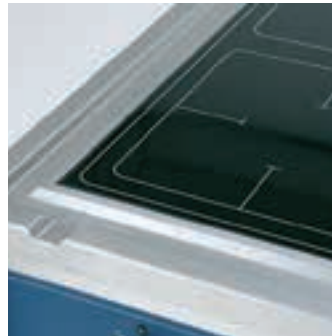

Ardox induction range surface is glass ceramics and cooking zones are square



Ardox induction range panel



In the combi model Ardox IC the induction cooking zones are square and infrared zones round.



Ardox glass ceramic range panel



# ARDOX I & IC

Ardox	Code	Dimensions mm	El. connection
Metos Ardox I 2	4210010	500 x 800 x 900	400V 3N~ 7kW
Metos Ardox I 4	4210011	800 x 800 x 900	400V 3N~ 14kW
Metos Ardox I 6	4210012	1200 x 800 x 900	400V 3N~ 21kW
Metos Ardox IC 4	4210017	800 x 800 x 900	400V 3N~ 12kW
Ardox I 4 H	4210019	800 x 800 x 900	400V 3N~ 14.1kW
Ardox I 6 H	4210020	1200 x 800 x 900	400V 3N~ 21.1kW
Ardox IC 4 H	4210038	800 x 800 x 900	400V 3N~ 12kW

The H models are with height adjustment, adjustment range is 70 – 90 cm

Also Tabletop models available.



Metos Ardox IC 4

All the Ardox I, IC and C ranges are similar in dimensions and looks. All have the depth of 800mm and height of 900mm. The widths are 500mm (2 zones), 800mm (4 zones) and 1200mm (6 zones). The 2 and 4 zone models have one glass plate, whereas the 6 zone model has two separate glass plates. All have a groove round the glass plate to collect any spillage or cleaning water.



Metos Ardox I 2

# ARDOX C

The stand of the C 4 /220 and C 6 /220 model is fitted with a Metos Chef 220 roasting-baking oven. The stand of the C 4 /240 and C 6 /240 model is fitted with a Metos Chef 240 convection oven.

Ardox	Code	Dimensions mm	El. connection
Metos Ardox C 2	4210025	500 x 800 x 900	400V 3N~ 6.5kW
Metos Ardox C 4	4210026	800 x 800 x 900	400V 3N~ 13kW
Metos Ardox C 6	4210027	1200 x 800 x 900	400V 3N~ 19.5kW
Ardox C 4 /220	3752020	800 x 800 x 900	400V 3N~ 17.5kW
Ardox C 4 /240	3752021	800 x 800 x 900	400V 3N~ 20.5kW
Ardox C 6 /220	3752022	1200 x 800 x 900	400V 3N~ 24.2kW
Ardox C 6 /240	3752023	1200 x 800 x 900	400V 3N~ 27kW
Ardox C 4 H	4210058	800 x 800 x 900	400V 3N~ 13.1kW
Ardox C 6 H	4210059	1200 x 800 x 900	400V 3N~ 19.6kW

The H models are with height adjustment, adjustment range is 70 – 90 cm

Also Tabletop models available.

Installation drawing p. 147.



Metos Ardox C 4 with convection oven in the stand.



The open stand has one shelf with rounded edges. In the back legs there are bolt holes for sturdy installation.



The Ardox C range is available with Metos Chef oven in the stand.

## METOS FUTURA RP MODELS



Metos Futura RP range with cast iron hotplates

**Metos Futura RP** range hotplates are of durable cast iron. The range is easy to clean. The 300x300 mm hotplates are hinged, so they can be lifted up for cleaning. Beneath the hotplates there is a removable spillage tray. Each hotplate has seven settings and an indicator light. A detachable shelf is included in the stand of RP2, RP4 and RP6 models as standard. The stand of RP4/220 and RP6/220 ranges is fitted with a Metos Chef 220 roasting-baking oven. The stand of RP4/240 and RP6/240 ranges is fitted with a Metos Chef 240 convection oven.



It is easy to keep the range clean, as the hinged hotplates of the RP range can be lifted up and all parts likely to get dirty can be easily cleaned.



Metos Futura RP4/240 range with Chef 240 convection oven in the stand.

Metos	Code	Cooking plates	Dimensions mm	Electric connection
RP2	3494319	2 x 3 kW	500x800x900	400V 3N~ 6.0 kW
RP4	3494358	4 x 3 kW	800x800x900	400V 3N~ 12.0 kW
RP6	3494397	6 x 3 kW	1200x800x900	400V 3N~ 18.0 kW
RP 4/220	3751993	4 x 3 kW	800x800x900	400V 3N~ 16.7 kW
RP 4/240	3751997	4 x 3 kW	800x800x900	400V 3N~ 19.6 kW
RP 6/220	3752004	6 x 3 kW	1200x800x900	400V 3N~ 23.5 kW
RP 6/240	3752008	6 x 3 kW	1200x800x900	400V 3N~ 25.6 kW
RP4 H	4210002	4 x 3 kW	800x800x900	400V 3N~ 12.1 kW
RP6 H	4210004	6 x 3 kW	1200x800x900	400V 3N~ 18.1 kW

The H models are with height adjustment, adjustment range is 70 – 90 cm

Installation drawing p. 148.





## METOS MINOR



**Metos Minor 4** is the RP4-range miniature. The external measures are 600 x 600 x 900 mm so it fits perfectly a small kitchen with 600 mm work bench depth. Hinged hotplates of cast iron 220 x 220 mm, 4 x 2 kW. Each hotplate has a 4-steps power regulator and a signal light. Under the hotplates is a removable tray of stainless steel for easy cleaning. Open stand with a shelf.



It is easy to keep the range clean, as the hinged hotplates of the range can be lifted up and all parts likely to get dirty can be easily cleaned.

Metos	Code	Cooking plates	Dimensions mm	Electric connection
Minor	3753592	4x 2 kW	600x600x900	400V 3N~ 8,0 kW 16A

Installation drawing p. 149.





# METOS PRINCE BRATT PANS

**Metos Prince** is a bratt pan that is permanently fixed to the floor. All Metos Prince models are fitted with electrical tilting. The pan is heated in few minutes (+200°C). The temperature is uniform throughout the whole pan area. Thermostat controlled temperature 50-250°C.

The Metos Prince bratt pan with strong electrical tilting is securely fixed to the floor. The bratt pan is easy to use. The green lamp indicates when the pan is in operation and the yellow lamp goes out when the pan is ready for use. The balanced lid is formed so that the condensation water returns into the pan.

The pan is easy to clean, since all surfaces throughout – except for the pan area – are stainless steel quality 18/8. The pan area is sandblasted steel and the corners are rounded. Optionally available with compound surface, then the 12 mm steel base is covered with 2,5 mm stainless steel surface.

The frying area in Metos Prince 60 is 540x530 mm and 790x530 mm in Prince 85.

The pans can be supplied with food water filling by a push button and ergonomic height adjustment 800 - 950 mm.

Maintenance from the front. The installation frame is same size as in previous Prince model so old Prince pans can easily be replaced with this one. The new Prince can be attached to wall also.



Metos Prince 85

- fast and efficient
- reliable
- ergonomic and easy to keep clean
- for heavy use



Metos Prince	Code	Dimensions mm	Pan depth	Volume l	El. connection
Prince 60L	3755400	600x818x960	90	25	400V 3N~ 7,5kW 10A
Prince 60D	3755401	600x818x960	130	37	400V 3N~ 7,5kW 10A
Prince 85L	3755402	850x818x960	90	37	400V 3N~ 10,5kW 15A
Prince 85D	3755403	850x818x960	180	75	400V 3N~ 10,5kW 15A
Options	Code				
S/s compound surface 60	3755410				
S/s compound surface 85	3755411				
Height adjustment	3755414				
Water filling	3755416				

Installation drawing p. 150-151.



Light balanced lid stays in upright position



Rounded corners facilitate cleaning



# METOS FUTURA BRATT PANS

**Metos Futura** bratt pan series offers a wide range of models for versatile, efficient and ergonomic frying in every kitchen.

The Metos Futura bratt pan ensures high frying efficiency, uniform heat distribution and fast heat recovery. Temperature adjustment range is 0...250°C. Metos Futura is quicker and more efficient than conventional bratt pans, especially when frying cold products.

Metos Futura pans can be supplied with food water filling by a push button.

Metos Futura pans have a strong electrical tilting as standard. The pans are available also with manual tilting and ergonomic height adjustment 800 - 950 mm.

Metos Futura 85 or 110 pans can be either 90 or 180 mm deep which makes them very suitable also for simmering and cooking of products.

Metos Futura 110 is a versatile bratt pan with two separately controlled frying zones. This feature makes it possible to fry two products requiring different frying temperatures at the same time. The other way to use the frying pan is to fry a product on one zone and use the other for temporary holding.

All outer surfaces of Metos Futura bratt pan are made of stainless steel throughout. The frying surface is 10 mm thick steel which stores heat extremely well. Optionally available with compound surface, then the 12 mm steel base is covered with 2,5 mm stainless steel surface.

Uniform surfaces and compact construction and rounded corners on the frying surface make cleaning easy.



Metos Futura 85



Metos Futura 110 with height adjustment and water filling



Water filling through the lid



Water tap

## METOS FUTURA 60

An efficient bratt pan for small spaces. The frying area of the Metos Futura 60 bratt pan is 540x530x90 mm. The pan volume is 25 liters. One stepless temperature control for the whole frying surface. The pan has electrical tilting, manual tilting available as option.

Metos	Code	Dimensions mm	Electric connection
Futura 60L	3755404	600x806x954	400V 3N~ 7,5 kW 10A
Options	Code		
S/s compound surface	3755410		
Manual tilting	3755413		
Height adjustment	3755415		
Water filling	3755417		



Metos Futura 60

## METOS FUTURA 85

The frying area of the Metos Futura 85 bratt pan is 790x530 mm. The pan depth of L models is 90 mm and volume 37 liters, D models pan depth is 180 mm and volume 75 liters. Stepless temperature control. The pan has electrical tilting, manual tilting available as option.

Metos	Code	Dimensions mm	Electric connection
Futura 85L	3755406	850x806x954	400V 3N~ 10,5 kW 15A
Futura 85D	3755407	850x806x954	400V 3N~ 10,5 kW 15A
Options	Code		
S/s compound surface	3755411		
Manual tilting	3755413		
Height adjustment	3755415		
Water filling	3755417		



Metos Futura 85 with an optional manual tilting

## METOS FUTURA 110

The frying area of the Metos Futura 110 bratt pan is 1040x530 mm. The frying surface has been divided into two frying zones that can be controlled separately. Stepless temperature control. The pan depth of L models is 90 mm and volume 50 liters, D models pan depth is 180 mm and volume 100 liters. The pan has electrical tilting, manual tilting available as option.

Metos	Code	Dimensions mm	Electric connection
Futura 110L	3755408	1100x806x954	400V 3N~ 15,0 kW 21A
Futura 110D	3755409	1100x806x954	400V 3N~ 15,0 kW 21A
Options	Code		
S/s compound surface	3755412		
Manual tilting	3755413		
Height adjustment	3755415		
Water filling	3755417		



Metos Futura 110

Installation drawing p. 152.

## Wireless temperature tracking for HACCP



**Metos Tempnet wireless HACCP options** include a temperature tracking system that provides real-time temperature measurement. This can be monitored anywhere the internet is accessible including a mobile version for cell phones and tablets. The user can access on all information online and receive alarms as text messages if preset limits are breached. All this is linkable to the other key equipment in the kitchen, such as dishwashers, refrigeration, ovens and buffet areas. **There are no servers to worry about, no software to install.** Sensors in appliances send data wirelessly, through a base station. Just log on and you are ready to go. The perfect paperless, in-house control system.



- Automatic
- Wireless
- Real-time
- Easy to install
- Device independent
- Modular
- Accessed via Internet
- 24/7 maintenance
- Incorruptible
- Alarm messages sent as SMS
- Extendable



# METOS TEMPNET® HACCP SYSTEM

**Metos TempNet® provides a fully automated and wireless monitoring system enabling real-time monitoring and saving the gathered data for professional kitchens:**

- **when checking incoming food deliveries**
- **in freezers and fridges**
- **in cold rooms and cold kitchens**
- **during food preparation, heating and cooling**
- **when serving and selling warm food**
- **during transportations**
- **in dishwashing**

Metos TempNet® system consists of internet user interface, and easy to install equipment (a base station, a sensor for temperature measuring and hand-held devices as required by the client).

Metos TempNet® allows you to follow different measuring spots and locations in the same browser view wherever via internet.

Automatic monitoring system helps to minimize work-time and human mistakes are avoided. The system is quick and easy to install and it is compatible with all equipment regardless of their brand.

Alerts on possible deviations in temperatures are sent to the chosen mobile phone number. The system stores data securely for later use.

Costs are easy to count: a one-time investment into equipment and a fixed monthly fee for maintaining the data and the system for 24/7. All reports, alarms, unlimited user rights and updates are included in the system maintenance i.e. are not invoiced separately. No additional IT support expenses or internal resources are required for maintaining the system.

Metos TempNet® fulfills EU standards (1st Jan 2010) for measuring food temperature.

*Metos TempNet browser view*



- **Fully automated wireless temperature recording system**
- **Real-time temperature measuring and control where required**
- **Device independent and modular structure**
- **Modular, easy to extend**
- **Compatible with devices produced by other kitchen equipment manufacturers**
- **Suitable for measuring both high and low temperatures between -50°C...+250 °C**
- **Collects, stores and retrieves information (e.g. in ERP systems)**
- **SMS alerts sent to phone – deviation limits defined in user interface**
- **Maintenance, service and software updates via remote connection**

# METOS TEMPNET® HACCP SYSTEM



2G base station



Ethernet base station



Kettle sensor



Cooking sensor



Temperature sensor



Handy handheld unit and probe

Starter kits	Code	
TempNet Package 1	4007015	1 x 4007023 (2G) ja 3 x 4007052
TempNet Package 2	4007017	1 x 4007021 (Ethernet) and 3 x 4007052

Maintenance fee	Code	
Maintenance 24/7	4007013	from 1 eur / month (TempNet package 1 and 2)

Base stations	Code	
Base station 2G	4007037	230 V with antenna reinforce
Base station Ethernet	4007021	230 V

Accessories	Code	
Antenna wire 1 metre	4007027	

Kettle sensors	Code	
Wireless HACCP sensor	4007060	Culino and Viking kettles with HACCP facility
Wireless HACCP sensor	4222186	Proveno 2G kettles

Temperature sensors for cooking and warm holding	Code	
Cooking sensor	4007064	-50°C...+250°C ovens
Sensor with thin measure head	4007068	-60°C...+250°C GN containers, delivery



Sensor with thin measure head

Temperature sensors for cold storage	Code	
Temperature sensor	4007052	-30°C... +75°C fridges, cold rooms
Temperature sensor, 1 m cable	4007054	-30°C... +75°C fridges, cold rooms
Temperature sensor, 2 m cable	4007056	-30°C... +75°C fridges, cold rooms
Temperature sensor, 3 m cable	4007058	-30°C... +75°C fridges, cold rooms

Handheld unit	Code	
Handy handheld unit	4007072	Includes probe, charger and wall holder
Handy handheld unit 3G*	4007092	Includes probe, charger and wall holder

Core probes	Code	
Probe ø 2,5 mm	4007074	accuracy ±0,5°C, time between measures 15 sec
Probe ø 1,5 mm	4007076	accuracy ±0,5°C, time between measures 15 sec

TempNet – Standard features	Extra features
Measuring of temperature Storing, maintaining and fetching of data Basic reports Data display for inspectors Alarms Abnormalities Equipment control User control Documentation	All kitchens in the same interface System status messages sent automatically to email Automatic noncompliance report to email A spare battery for the self-monitoring system Monitoring view that covers all measuring points Temperature and alarm data for the kitchen lay-out via web interface





# METOS DROP-IN COLLECTION



**Metos drop-in collection** gives a possibility to create flexible and unique food serving solutions with reasonable costs. The idea of the collection is to build a unique food serving line by using standard technical units.

The drop-in collection comprises all the units for building a food serving line. These drop-in units can be integrated into various kinds of decorative solutions.

The collection includes units for serving cold and warm products, as well as soup. Units needed for dispensing plates, trays etc. are also available in the collection. With the drop-in units we can create custom made solution together with the customer.

Customer can purchase the technical units from Metos, and design the outlook of the serving line separately. For this purpose Metos provides the necessary information for design and production of the serving line. This guarantees right performance and durability of the drop-in units. Metos can also supply the complete custom made drop-in serving line as a turnkey delivery.



Units collar can be placed on the top of table surface



...or installed deeper to make smooth surfaces

## METOS DROP-IN COLLECTION



For serving cold food there are cold basins, frost planes and crushed ice basins. The insulated cold basins and frost planes are equipped with powerful cooling machinery. These units can be delivered also with connection to remote cooling system. Crushed ice basins are without cold machine. Due to the insulation of the basin, the ice does not melt totally during the normal food serving hours. All the models are available at the sizes of 1-4 GN 1/1. Depth of basin is 160 mm and frost plane 20 mm.

For serving warm meals there are bain-maries, ceramic hot plates and integrated soup dispensers. Basins with depth of 160 mm and ceramic hot plates can be delivered at the sizes of 1-3 GN 1 / 1. If necessary, the bain-maries can be delivered with depth of 210 mm.



A heated soup bowl dispenser can be placed next to the soup dispenser. This guarantees that the soup bowls have the right temperature before use. Together these two units form a tempting soup station.



The drop-in collection has various supplementary equipment for the food serving lines: Plate dispensers are available for three different plate sizes, cutting-board and crumb box combination for cutting bread in the serving line and rack and tray dispensers.

For dispensing water there are drop-in dispensers that can be supplied with or without cooling machinery. Faucets can be either mechanic or electronic. An electronic faucet guarantees a hygienic operation because the customer does not need to touch the faucet either with hand or with glass. In addition to the standard water dispenser models also water dispensers producing soda water are offered.



# METOS DROP-IN WITH UPPER SHELF

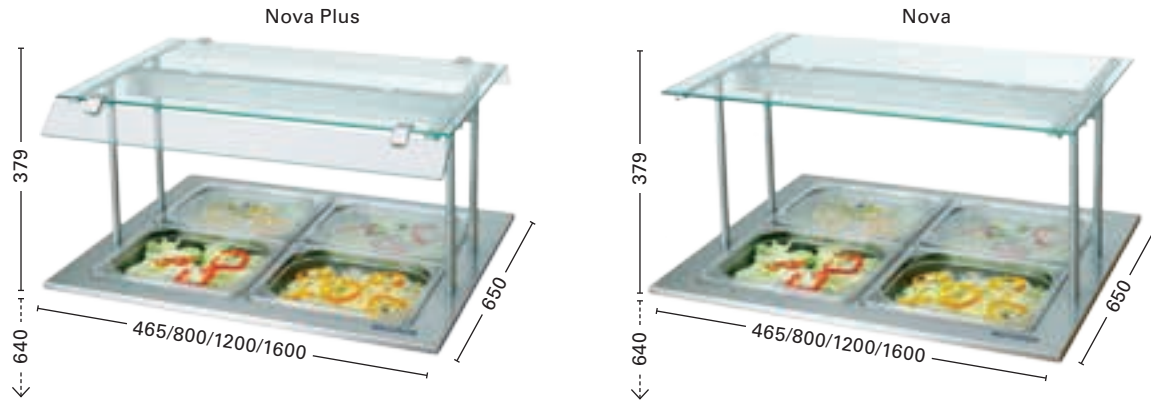

	NOVA PLUS	NOVA	Electric 230V 1~
<b>Cold basin LED</b>			
D-I CB 450	4322041	4138741	0,43 kW 10A
D-I CB 800	4322043	4138743	0,43 kW 10A
D-I CB 1200	4322045	4138745	0,43 kW 10A
D-I CB 1600	4322047	4138747	0,43 kW 10A
<b>Crushed ice basin LED</b>	<b>Nova Plus</b>	<b>Nova</b>	<b>Electric 230V 1~</b>
D-I CIB 450	4322049	4138749	0,03 kW 10A
D-I CIB 800	4322051	4138751	0,03 kW 10A
D-I CIB 1200	4322053	4138753	0,03 kW 10A
D-I CIB 1600	4322055	4138755	0,03 kW 10A
Base heightening GN1/1-50	4136845	4136845	
<b>Frost plane LED</b>	<b>Nova Plus</b>	<b>Nova</b>	<b>Electric 230V 1~</b>
D-I FrP 450	4322057	4138757	0,43 kW 10A
D-I FrP 800	4322059	4138759	0,43 kW 10A
D-I FrP 1200	4322061	4138761	0,43 kW 10A
D-I FrP 1600	4322063	4138763	0,43 kW 10A
<b>Bain marie LED</b>	<b>Nova Plus</b>	<b>Nova</b>	<b>Electric 230V 1~</b>
D-I BM 450 LED	4322065	4138765	1,8 kW 16A
D-I BM 800 LED	4322067	4138767	1,8 kW 16A
D-I BM 1200 LED	4322069	4138769	1,8 kW 16A
<b>Ceramic plate LED</b>	<b>Nova Plus</b>	<b>Nova</b>	<b>Electric 230V 1~</b>
D-I CPL 450 LED	4322071	4138771	0,3 kW 16A
D-I CPL 800 LED	4322073	4138773	0,5 kW 16A
D-I CPL 1200 LED	4322075	4138775	0,9 kW 16A
<b>Bain marie HALOTHERM</b>	<b>Nova Plus</b>	<b>Nova</b>	<b>Electric 230V 1~</b>
D-I BM 450 H	4322076	4138776	2,0 kW 16A
D-I BM 800 H	4322078	4138778	2,2 kW 16A
D-I BM 1200 H	4322080	4138780	2,4 kW 16A
<b>Ceramic plate HALOTHERM</b>	<b>Nova Plus</b>	<b>Nova</b>	<b>Electric 230V 1~</b>
D-I CPL 450 H	4322082	4138782	0,5 kW 16A
D-I CPL 800 H	4322084	4138784	0,9 kW 16A
D-I CPL 1200 H	4322086	4138786	1,5 kW 16A
<b>Separate upper part LED</b>	<b>Nova Plus</b>	<b>Nova</b>	<b>Electric 230V 1~</b>
450-L	4321985	4138691	0,03 kW 10A
800-L	4321987	4138693	0,03 kW 10A
1200-L	4321989	4138695	0,03 kW 10A
1600-L	4321991	4138697	0,03 kW 10A
<b>Separate upper part HALOTHERM</b>	<b>Nova Plus</b>	<b>Nova</b>	<b>Electric 230V 1~</b>
450-H	4321998	4138698	0,2 kW 10A
800-H	4321996	4138696	0,4 kW 10A
1200-H	4322006	4138706	0,6 kW 10A

Nova sneeze guards retrofit	Code	Dimensions mm
Sneeze guards Nova Plus 450	4308966	450
Sneeze guards Nova Plus 800	4308968	800
Sneeze guards Nova Plus 1200	4308970	1200
Sneeze guards Nova Plus 1600	4308972	1600

Plastic protection to glass edge	Code	Dimensions mm
Plastic protection to glass edge 450	4308967	450
Plastic protection to glass edge 800	4308969	800
Plastic protection to glass edge 1200	4308971	1200
Plastic protection to glass edge 1600	4308973	1600

# METOS DROP-IN WITH UPPER SHELF



	SKY	PROFF	Electric 230V 1~
<b>Cold basin LED</b>			
D-I CB 450	4322116	—	0,43 kW 10A
D-I CB 800	4322118	4138854	0,43 kW 10A
D-I CB 1200	4322120	4138856	0,43 kW 10A
D-I CB 1600	4322122	4138858	0,43 kW 10A
<b>Crushed ice basin LED</b>	<b>Sky</b>	<b>Proff</b>	<b>Electric 230V 1~</b>
D-I CIB 450	4322124	—	0,03 kW 10A
D-I CIB 800	4322126	4138862	0,03 kW 10A
D-I CIB 1200	4322128	4138864	0,03 kW 10A
D-I CIB 1600	4322130	4138866	0,03 kW 10A
Base heightening GN1/1-50	4136845	4136845	
<b>Frost plane LED</b>	<b>Sky</b>	<b>Proff</b>	<b>Electric 230V 1~</b>
D-I FrP 450	4322132	—	0,43 kW 10A
D-I FrP 800	4322134	4138870	0,43 kW 10A
D-I FrP 1200	4322136	4138872	0,43 kW 10A
D-I FrP 1600	4322138	4138874	0,43 kW 10A
<b>Bain marie LED</b>	<b>Sky</b>	<b>Proff</b>	<b>Electric 230V 1~</b>
D-I BM 450 LED	—	—	1,8 kW 16A
D-I BM 800 LED	—	4138878	1,8 kW 16A
D-I BM 1200 LED	—	4138880	1,8 kW 16A
<b>Ceramic plate LED</b>	<b>Sky</b>	<b>Proff</b>	<b>Electric 230V 1~</b>
D-I CPL 450 LED	—	—	0,3 kW 16A
D-I CPL 800 LED	—	4138884	0,5 kW 16A
D-I CPL 1200 LED	—	4138886	0,9 kW 16A
<b>Bain marie HALOTHERM</b>	<b>Sky</b>	<b>Proff</b>	<b>Electric 230V 1~</b>
D-I BM 450 H	4322140	—	2,0 kW 16A
D-I BM 800 H	4322142	4138902	2,2 kW 16A
D-I BM 1200 H	4322144	4138904	2,4 kW 16A
<b>Ceramic plate HALOTHERM</b>	<b>Sky</b>	<b>Proff</b>	<b>Electric 230V 1~</b>
D-I CPL 450 H	4322146	—	0,5 kW 16A
D-I CPL 800 H	4322148	4138908	0,9 kW 16A
D-I CPL 1200 H	4322150	4138910	1,5 kW 16A
<b>Separate upper part LED</b>	<b>Sky</b>	<b>Proff</b>	<b>Electric 230V 1~</b>
450-L	4322108	—	0,03 kW 10A
800-L	4322110	4138916	0,03 kW 10A
1200-L	4322112	4138918	0,03 kW 10A
1600-L	4322114	4138740	0,03 kW 10A
<b>Separate upper part HALOTHERM</b>	<b>Sky</b>	<b>Proff</b>	<b>Electric 230V 1~</b>
450-H	4322098	—	0,2 kW 10A
800-H	4322100	4138926	0,4 kW 10A
1200-H	4322102	4138928	0,6 kW 10A

Accessory SKY	Code	
End glass SKY	4321724	for D-I unit
End glass SKY	4321718	for upper part only

# METOS DROP-IN WITHOUT UPPER SHELF



Cold basin	Code	Dimensions	Electric 230V 1~
D-I CB 450	4138646	465x650x640	0,4 kW 10A
D-I CB 800	4138656	800x650x640	0,4 kW 10A
D-I CB 1200	4138666	1200x650x640	0,4 kW 10A
D-I CB 1600	4138674	1600x650x640	0,4 kW 10A



Crushed ice basin	Code	Dimensions	Electric 230V 1~
D-I CIB 450	4138650	465x650x230	—
D-I CIB 800	4138660	800x650x230	—
D-I CIB 1200	4138670	1200x650x230	—
D-I CIB 1600	4138678	1600x650x230	—
Base heightening	4136845	500x300x50	



Frost plane	Code	Dimensions	Electric 230V 1~
D-I FrP 450	4138648	465x650x500	0,4 kW 10A
D-I FrP 800	4138658	800x650x500	0,4 kW 10A
D-I FrP 1200	4138668	1200x650x500	0,4 kW 10A
D-I FrP 1600	4138676	1600x650x500	0,4 kW 10A



Bain marie	Code	Dimensions	Electric 230V 1~
D-I BM 450	4138644	465x650x355	1,8 kW 16A
D-I BM 800	4138654	800x650x355	1,8 kW 16A
D-I BM 1200	4138664	1200x650x355	1,8 kW 16A



Ceramic plate	Code	Dimensions	Electric 230V 1~
D-I CPL 450	4138652	465x650x355	0,3 kW 16A
D-I CPL 800	4138662	800x650x355	0,5 kW 16A
D-I CPL 1200	4138672	1200x650x355	0,9 kW 16A



Integrated soup dispenser	Code	Dimensions	Electric 230V 1~
D-I soup well 10 litres	4138930	Ø312 x 323	0,4 kW 10A
Innerpart 10 litres	4138933		
Soup well's lid	4138934		



Soup bowl dispenser	Code	Dimensions	Electric 230V 1~
D-I SBD 300x300	4138932	380 x 340 x 680	0,5 kW 10A

\* The inside dimensions of the soup bowl dispenser 300 x 300 x 680 mm

# METOS DROP-IN WITHOUT UPPER SHELF

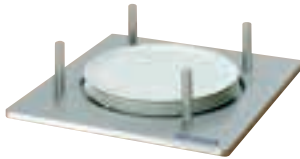
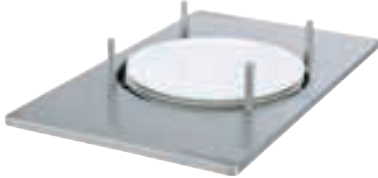
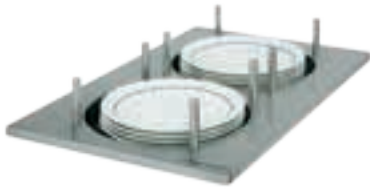

Plate dispensers Ø 270 max	Code	Dimensions	Electric 230V 1
D-I PDW 2x270 warm	4138944	400x650x720	0,7 kW 10A
D-I PD 2x270 neutral	4138940	400x650x635	—
D-I PDW 2x270- 750 warm	4138946	400x650x570	0,7 kW 10A
D-I PD 2x270- 750 neutral	4138942	400x650x484	—

Plate dispensers Ø 320 max	Code	Dimensions	Electric 230V 1~
D-I LPDW 320 warm	4138950	400x650x720	0,7 kW 10A
D-I LPD 320 neutral	4138948	400x650x635	—

Plate dispensers neliö Ø 320 max	Code	Dimensions	Electric 230V 1~
D-I LPDW-S 320 warm	4138954	420x420x720	0,7 kW 10A
D-I LPD-S 320 neutral	4138952	420x420x635	—

Accessories for plate dispensers	Code	Dimensions
Adjustment bars 900	4203972	
Adjustment bars 750	4203970	
Cover for cylinder 270	4203966	288x288x55
Cover for cylinder 320	4203968	360x360x55

Basket dispensers	Code	Dimensions
D-I BD-900	4138553	590x590x650 —
D-I BD-750	4138555	590x590x550 —

Tray dispensers	Code	Dimensions
D-I TD 900	4138578	424x524x650 —
D-I TD 750	4138580	424x524x550 —

Water dispensers			
<b>refrigerated one-sided</b>			
D-I WD mechanical faucet	4213325	330x400	0,5 kW 10A
D-I WD-E electric faucet	4213327	330x400	0,5 kW 10A
<b>refrigerated two-sided</b>			
D-I WD-2 mechanical faucet	4213341	330x640	0,5 kW 10A
D-I WD-E-2 electric faucet	4213342	330x640	0,5 kW 10A
<b>neutral one-sided</b>			
D-I WD-N mechanical faucet	4213329	330x400	—
D-I WD-EN electric faucet	4213331	330x400	0,1 kW
<b>neutral two-sided</b>			
D-I WD-N-2 mechanical faucet	4213343	330x640	—
D-I WD-EN-2 electric faucet	4213344	330x640	0,1 kW
Filter unit	4213335	*to be ordered with the dispenser	

Soda water dispenser			
<b>refrigerated one-sided</b>			
D-I WD-M soda mechanical faucet	4213348	330x400	0,5 kW 10A
D-I WD-E soda electric faucet	4213346	330x400	0,5 kW 10A

The gas bottles needed for the soda water dispensers are not included in the unit. A separate leasing contract needs to be made with a specified gas supplier.

Water dispenser installation drawing p. 152.

Cutting board with crumb box	Code	Dimensions
D-I Cutting board	4138714	500x285x20 —

# METOS NOVA SERVING COUNTERS

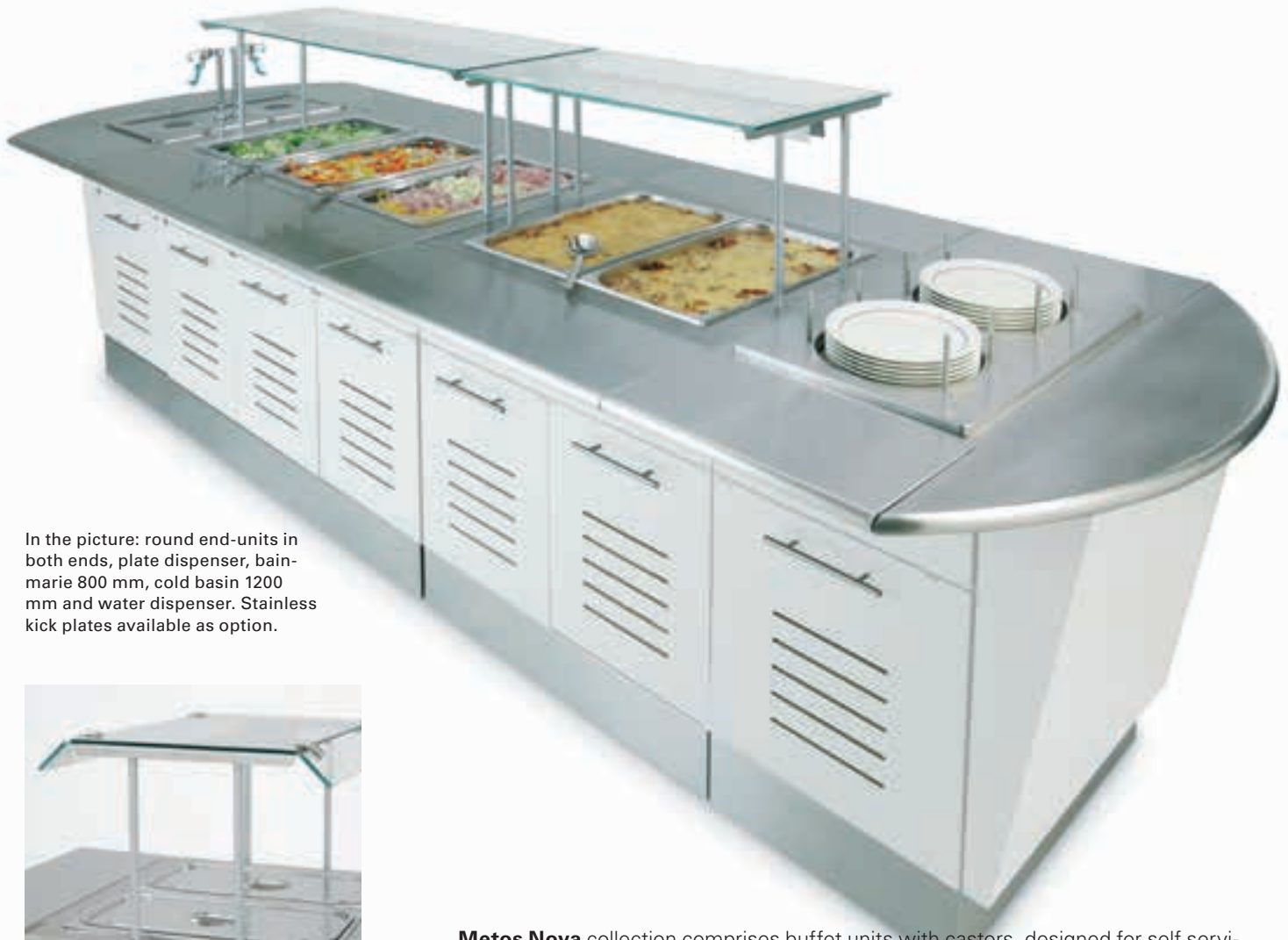

In the picture: round end-units in both ends, plate dispenser, bain-marie 800 mm, cold basin 1200 mm and water dispenser. Stainless kick plates available as option.

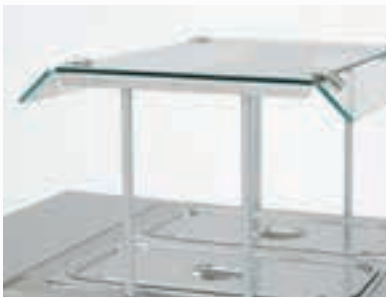

Standard upper shelf is hardened glass. Warm units are equipped with LED lighting or Halotherm heat radiator.

**Metos Nova** collection comprises buffet units with castors, designed for self service. All the castors can be locked thus keeping the units in place steadily. The units can be used stand-alone or combined to create a self-service line to meet customer's individual needs.



All Nova basins are seamless and corners are rounded for easier cleaning.

There are a lot different end-units that can be used in food serving line instead of standard laminated ending. These end-units can be used for example to distribute trays, as place for decorative objects or simply to end the serving line elegantly. The collection comprises normal food serving equipment and special units like cashier units but, thanks to its modularity, opens excellent possibilities for tailor made solutions, as well.

With the Nova corner unit L-shaped serving lines can efficiently be created either against the wall or in the middle of a space. The standard corner unit is neutral with a cupboard and a table top made of stainless steel. The neutral unit can function e.g. as a bread table. With the help of configuration it is possible to insert 400 mm cold and warm drop-in units into the basic corner unit. In addition, different kinds of dispensers such as water dispensers and rack dispensers can be inserted in the basic unit.



The units are provided with fold-down tray slides. Standard depth of the tray slide is 250 mm. Wooden trays slides are available for additional price. The sneeze guard is hardened glass and includes lighting. The heated units can be provided with a halotherm heating which gives both light and heats food from the above, thus keeping the served food in optimal serving temperature for a longer period. All the Nova units can be delivered also with Nova Plus, Sky or Proff upper shelves (see Metos drop-in collection). Standard heights for the serving units are 900 mm and 750 mm. The standard depth of the cold basin and the bain-marie basin is 160 mm, also deeper basins available.

Standard colors for the cover plates are grey, white, oak and birch. Also other colors and materials can be offered. Stainless steel kick plates are available for all the units as an accessory. Connectors that are used to combine two units together from under the tray slides are delivered with every unit.



# METOS NOVA SERVING COUNTERS

## Nova standard colours



Grey  
F7912

White  
K1040

Oak  
F2510

Birch  
K7024

- four standard colours, other colours and materials offered
- two serving heights, 900 or 750 mm
- upper part with LED lighting and hardened glass shelf
- Stainless steel tray slides 250 mm as standard



Nova cold basin 1200

## Units with upper shelf

	Normal height	Low height	Dimensions mm	Electric connection
<b>Nova cold basin LED</b>	<b>1280/900 mm</b>	<b>1130/750 mm</b>		
CB 450 LED	4318799	4319999	465x650/1150	230 V 1~0,43 kW 10A
CB 800 LED	4318801	4319001	800x650/1150	230 V 1~0,43 kW 10A
CB 1200 LED	4318803	4319003	1200x650/1150	230 V 1~0,43 kW 10A
CB 1600 LED	4318805	4319005	1600x650/1150	230 V 1~0,43 kW 10A

## Nova bain-marie with halotherm heat lamp

BM 450 H	4318810	4319010	465x650/1150	230 V 1~2,0 kW 16A
BM 800 H	4318826	4319026	800x650/1150	230 V 1~2,2 kW 16A
BM 1200 H	4318850	4319050	1200x650/1150	230 V 1~2,4 kW 16A

## Nova bain-marie LED

BM 450 LED	4318807	4319007	465x650/1150	230 V 1~1,0 kW 16A
BM 800 LED	4318837	4319037	800x650/1150	230 V 1~1,4 kW 16A
BM 1200 LED	4318847	4319047	1200x650/1150	230 V 1~2,25 kW 16A

## Nova neutral units LED

N 450 LED	4318811	4319011	465x650/1150	230 V 1~0,03 kW 10A
N 800 LED	4318813	4319013	800x650/1150	230 V 1~0,03 kW 10A
N 1200 LED	4318815	4319015	1200x650/1150	230 V 1~0,03 kW 10A
N 1600 LED	4318817	4319017	1600x650/1150	230 V 1~0,03 kW 10A

## Nova crushed ice basin LED

CIB 450 LED	4318825	4319025	465x650/1150	230 V 1~0,03 kW 10A
CIB 800 LED	4318819	4319019	800x650/1150	230 V 1~0,03 kW 10A
CIB 1200 LED	4318821	4319021	1200x650/1150	230 V 1~0,03 kW 10A
CIB 1600 LED	4318823	4319023	1600x650/1150	230 V 1~0,03 kW 10A

## Nova ceramic plate with halotherm heat lamp

CPL 450 H	4318812	4319012	465x650/1150	230 V 1~0,75 kW 16A
CPL 800 H	4318828	4319028	800x650/1150	230 V 1~1,45 kW 16A
CPL 1200 H	4318852	4319052	1200x650/1150	230 V 1~2,15 kW 16A

## Nova ceramic plate LED

CPL 450 LED	4318809	4319009	465x650/1150	230 V 1~0,75 kW 16A
CPL 800 LED	4318839	4319039	800x650/1150	230 V 1~1,45 kW 16A
CPL 1200 LED	4318849	4319049	1200x650/1150	230 V 1~2,15 kW 16A

## Nova frost plane LED

FrP 450 LED	4318829	4319029	465x650/1150	230 V 1~0,43 kW 10A
FrP 800 LED	4318831	4319031	800x650/1150	230 V 1~0,43 kW 10A
FrP 1200 LED	4318833	4319033	1200x650/1150	230 V 1~0,43 kW 10A
FrP 1600 LED	4318835	4319035	1600x650/1150	230 V 1~0,43 kW 10A



Nova cold basin 800



Nova bain-marie 800

# METOS NOVA SERVING COUNTERS

Units without upper shelf	Normal height	Low height	Dimensions mm
<b>Nova serving counter</b>	<b>900 mm</b>	<b>750 mm</b>	
SB 450	4318920	4319114	465x650/1150
SB 800	4318922	4319116	800x650/1150
SB 1200	4318924	4319118	1200x650/1150
SB 1600	4318925	4319119	1600x650/1150

Nova plate dispensers, heated	900 mm	750 mm	Dimensions mm	Electric connection
PDW 2x270	4318876	4319076	465x650/1150	0,7 kW 10 A

Nova plate dispensers, neutral	Height	Dimensions mm
PD 2x270	4318874	465x650/1150

Nova cashier unit	Height	Dimensions mm
Cashier unit double sided	4308910	1200x900/1400
Double sided cashier unit narrowing part NU	4308912	250x900
Cashier unit single sided	4308908	800x650/900

Nova end units	Height 900 mm	Height 750 mm	Dimensions mm
Tray end-unit 1 TM1	4308926	4309120	380x1150
Tray end-unit 2 TM2	4308928	4309122	600x1150
Tray end-unit 2, single sided TM2-1	4308930		600x900
Widened end-unit 1150	4308932	4309124	20x1150
Shelf end-unit ShM	4308934	4309126	250x1150
Rounded end-unit CM	4308936	4309128	250x1150

Nova corner unit	Height 900 mm	Height 750 mm	Dimensions mm
Neutral unit with plain s/s top	4319220	4319222	1150x1150

Nova water dispenser	Height 900 mm	Dimensions mm
Water dispenser WD, two-sided, refrigerated	4318878	465x650/1150
Water dispenser WD-N, two-sided, neutral	4318880	465x650/1150



Nova plate dispenser



Nova water dispenser



Neutral Nova corner unit with smooth stainless steel counter top. Nova corner units can be supplied with intergated cold basin, crush ice basin, frost plane, bain marie, ceramic plate, plate dispenser, water dispenser or basket dispenser.



Neutral Nova table unit

# METOS NOVA SERVING COUNTERS



Shelf end-unit ShM



Tray end-unit 1TM1



Tray end-unit 2TM2



Widened end-unit 1150

# METOS NOVA SERVING COUNTERS



Nova accessories	Code	
Cashiers display guard	4308962	270x620x300
Cutlery box	4308980	285x160x100
Fastening part	4308798	for connecting the tray slides to each other
Bain marie water filling	4309100	ordered together with bain marie
Heightening frame basin GN1/1-100	4136848	perforated
Heightening frame basin GN1/1-50	4136847	perforated
Heightening frame basin GN1/1-100	4136846	
Heightening frame basin GN1/1-50	4136845	
Cover plate GN1/1	4136806	on top of the basin
Cover plate GN2/1	4136813	on top of the basin
Cover plate GN3/1	4136838	on top of the basin
Cord channel 450 mm	4309104	in the bottom of the serving line
Cord channel 800 mm	4309106	in the bottom of the serving line
Cord channel 1200 mm	4309107	in the bottom of the serving line
Cord channel 1600 mm	4309108	in the bottom of the serving line
Cover plate	4309102	inside the cupboard

Nova s/s kick plates	Code
S/s plinths 450	4308938
S/s plinths 800	4308940
S/s plinths 1200	4308942
S/s plinths 1600	4308944
S/s plinths for tray end-unit 1	4308946
S/s plinths for tray end-unit 2	4308948
S/s plinths for shelf end-unit	4308950
S/s plinths for double sided cashier unit	4308952
S/s plinths for cashier unit narrowing part	4308954
S/s plinths for corner unit	4308956



Cutlery box



## METOS CORONA SERVING TROLLEYS



Corona upper part is fitted with a lamp and sneeze guards. The basin has rounded corners.



All the units have fold-down tray slides on both sides.

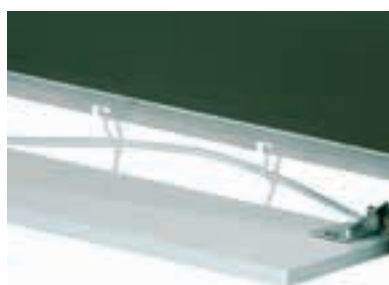

Electric wire holders

**Metos Corona** serving trolleys are mobile serving counters with castors, designed for self-service. The trolleys can be used individually or combined to create a self-service line to meet the customer's individual needs. The trolleys have a new flexible side panel construction which allows detaching and changing of the panels.

The standard side panel material is melamine. Standard colors are birch and cherry imitation, grey and red. Other colors and materials can be offered.

The trolleys have 250 mm wide fold-down tray slides on both sides. The standard depth of the cold and warm serving trolley basin is 160 mm.

The upper part is fitted with lamp and sneeze guards of tempered glass. The warm trolley upper part can be supplied with a Halotherm heater (option).

The Corona plate dispenser takes appr. 140 plates max  $\varnothing$  270 mm. Serving height is 900 or 750 mm. Easy rolling castors, two of which with brakes. Maintenance hatch is easy to reach. With a fastening part (option, code 4308798) the tray slides can be connected to each other.

# METOS CORONA SERVING TROLLEYS



The warm trolley with upperpart. Corona line offers a variety of colors. Pictured side panels in red melamine.



Corona cold trolley with upper shelf.

## Corona standard colors



Birch melamine    Cherry melamine    Grey melamine    Red melamine

- selection of standard colors: birch or cherry imitation and grey or red
- two serving heights 900 or 750 mm
- upper part with lamp and sneeze guards of tempered glass

	Normal height	Low height	Dimensions mm	Electric connection
<b>Cold serving trolley with upper part</b>	<b>900/1310</b>	<b>750/1160</b>		
CBUS 800	4309802	4309806	800x650/1150	230V1~50Hz 0,43 kW 10 A
CBUS 1200	4309810	4309814	1200x650/1150	230V1~50Hz 0,43 kW 10 A
<b>Cold serving trolley without upper part</b>	<b>Normal</b>	<b>Low</b>	<b>Dimensions mm</b>	<b>Electric connection</b>
CB 800	4309804	4309808	800x650/1150	230V1~50Hz 0,43 kW 10 A
CB 1200	4309812	4309816	1200x650/1150	230V1~50Hz 0,43 kW 10 A
<b>Warm serving trolley with upper part</b>	<b>Normal</b>	<b>Low</b>	<b>Dimensions mm</b>	<b>Electric connection</b>
BMUS 800	4309818	4309822	800x650/1150	230V1~50Hz 1,8 kW 16 A
BMUS 1200	4309826	4309830	1200x650/1150	230V1~50Hz 1,8 kW 16 A
<b>Warm serving trolley without upper part</b>	<b>Normal</b>	<b>Low</b>	<b>Dimensions mm</b>	<b>Electric connection</b>
BM 800	4309820	4309824	800x650/1150	230V1~50Hz 1,8 kW 10 A
BM 1200	4309828	4309832	1200x650/1150	230V1~50Hz 1,8 kW 10 A
<b>Serving trolley with upper part</b>	<b>Normal</b>	<b>Low</b>	<b>Dimensions mm</b>	<b>Electric connection</b>
N 800	4309842	4309844	800x650/1150	230V1~50Hz 18 W 10 A
N 1200	4309846	4309848	1200x650/1150	230V1~50Hz 30 W 10 A
<b>Serving trolley without upper part</b>	<b>Normal</b>	<b>Low</b>	<b>Dimensions mm</b>	
SB 800	4309834	4309836	800x650/1150	
SB 1200	4309838	4309840	1200x650/1150	
<b>Accessories</b>	<b>Code</b>			
Halotherm heater	4309860	for the upper part of the warm trolley		
Fastening part	4308798	for connecting the tray slides to each other		
Cord channel 500	4309105	in the bottom of the serving line		
Cord channel 800	4309106	in the bottom of the serving line		
Cord channel 1200	4309107	in the bottom of the serving line		



The neutral serving trolleys can be used e.g. for bread serving. The trolley is also available with upper part.



Fastening part for connecting tray slides

# METOS CORONA SERVING TROLLEYS



Metos Corona water dispenser is available either as neutral (N) or refrigerated. The hourly capacity of the water dispenser is 60 litres.

Water dispenser, refrigerated	Code	Dimensions mm	Electric connection
500 WD	4309870	500x650/1150x900/1140	230V1~ 0,5 kW 10A
500 WD-2	4309874	500x650/1150x900/1140	230V1~ 0,5 kW 10A
500/750 WD low	4309886	500x650/1150x750/990	230V1~ 0,5 kW 10A
500/750 WD-2 low	4309890	500x650/1150x750/990	230V1~ 0,5 kW 10A

Water dispenser, neutral	Code	Dimensions mm	Electric connection
500 WD-N	4309878	500x650/1150x900/1140	
500 WD-EN	4309880	500x650/1150x900/1140	230V1~ 0,1 kW 10A
500 WD-N-2	4309882	500x650/1150x900/1140	
500 WD-EN-2	4309884	500x650/1150x900/1140	230V1~ 0,1 kW 10A
500/750 WD-N low	4309894	500x650/1150x750/990	
500/750 WD-EN low	4309896	500x650/1150x750/990	230V1~ 0,1 kW 10A
500/750 WD-N-2 low	4309898	500x650/1150x750/990	
500/750 WD-EN-2 low	4309899	500x650/1150x750/990	230V1~ 0,1 kW 10A



The refrigerator is effective and reliable.



Corona water dispenser is equipped either with one or two faucets. There are two models of faucets, mechanical or electronic (E). The top has a glass dispenser and a sink with a drain for drip water.



Corona line offers both neutral and heated plate dispenser. The dispenser capacity is appr. 140 plates max ø 270 mm.

Plate dispenser, heated	Code	Dimensions mm	Electric connection
PDW 500	4309850	500x650/1150x900	230V1~50Hz 0,7 kW 10 A
PDW 500 low	4309854	500x650/1150x750	230V1~50Hz 0,7 kW 10 A

Plate dispenser, neutral	Code	Dimensions mm	
PD 500N	4309852	500x650/1150x900	
PD 500N low	4309856	500x650/1150x750	



# METOS FRESH SALAD TROLLEY



**Metos salad trolley** for self service sales of fresh salad meals. Suitable for serving in supermarkets, delis, cafes and restaurants.

Efficient airflow cooling technique in the basin. Temperature range is +2...+6°C. Displayed products are protected with doors with light gas springs that serve as sneeze guards when open. The LED lighting brings the goods out to their best. The trolley can be supplied with a selection of different shelves for the ends of the trolley. The standard side panels are black melamine. Also other customized colors, materials and prints can be offered.

## Accessories

- Different end shelves
- Customized side panel materials or prints

- stainless steel body
- black melamine panels
- doors on both sides
- doors serve as sneeze guards
- LED lighting
- light gas springs in doors
- electronic control
- automatic defrost
- plug-in connection
- lockable wheels
- 7 GN dividers
- airflow cooling technique (+2 ... +6°C)
- energy efficient
- air grids with magnetic fixing
- bottom valve in the basin
- service door in one side panel
- removeable side panels



End shelf 250 mm for salad boxes



End shelf 250 mm for GN containers



End shelf 500 mm for salad boxes



End shelf 600 mm for GN containers



End shelf 600 mm for GN containers and scale.

Metos Fresh	Code	Capacity	Dimensions mm	Electricity 230V
Salad trolley 185	4316000	5x GN 1/1	1850x800x900/1160	1,6 kW 10A

Accessories	Code	Capacity	Dimensions mm
End shelf 250 mm for salad boxes	4316006		250 mm
End shelf 250 mm for GN containers	4316008	4x GN 1/6	250 mm
End shelf 500 mm for salad boxes	4316010		500 mm
End shelf 600 mm for GN containers	4316018	8x GN 1/6	600 mm
End shelf 600 mm for GN containers and scale	4316014	4x GN 1/6	600 mm



## METOS HEATED PLATES



Metos LL-800

**Metos heated plate** is a durable and efficient heat source. The heating surface is made of thick hard-wearing stainless steel. The frame construction is made of sturdy powder-coated steel. Rubber pads keep the plate firmly in place. Pilot light and stepless temperature control in the front panel. Two sizes available.

LLM-800 model is similar to LL -model but there is large sneeze guard and heat radiators above the plate.

Metos	Code	Dimensions mm	Electric connection
LL 600	2024045	300x600x115	230V1~ 0,5 kW 10A
LL 800	2024044	800x600x115	230V1~ 1,0 kW 10A
LLM-800	4182496	800x600x680	230V1~ 1,5 kW 10A



Metos LLM-800

## METOS COLD PLATES

**Metos cold plate** is designed for use as a base for cream and milk jugs in serving lines. The plate is openable and of stainless steel throughout. A cold batch cooled in a freezer is used as a cold source inside the plate. Cold batches to be ordered separately, not included in the cold plate.

Metos	Code	Dimensions mm
Metos 250	4186719	250x150x60
Cold batch 250	4170194	
Metos 300	4186726	300x300x60
Cold batch 300	4170211	



Metos 250 / 300

## METOS WING SNEEZE GUARDS

**Metos WING** sneeze guard gives a nice appearance to a buffet and enhances hygiene. The mobile WING sneeze guard can be placed on the top of a unit, table or GN-basins. The frame support is made of stainless steel. The sneeze guard is made of hardened glass. The bottom edge of the glass is 330 mm from the table top. The sneeze guard is available in lengths 800 and 1200 mm, under which GN2/1 or GN3/1 basins fit. In both models the depth of the glass is 250 mm.

Metos	Code	Dimensions mm
Sneeze guard 800	4321246	780x345x330/436
Sneeze guard 1200	4321248	1180x345x330/436



Metos Wing 800

## METOS STANDS FOR GLASSES AND CUPS

**Metos shelves** for glasses and cups need a small space and are suitable for a variety of cups, glasses and plates. The frames of the shelves are made of stainless steel which makes them very steady. The glass shelves are made of thick shock-proof glass.

The height of the shelves in the round model are adjustable. The shelves with railings rotate easily on the ball bearings. The diameters of the shelves are 55, 50 and 45 cm. The shelf can fit up to 150 glasses. The rectangular model has two glass shelves with railings. The distance between the shelves is 33 cm. The legs are adjustable so that the shelf stays steady on the table top.

The square-shaped or rectangular shaped CUPPI shelf is available in stainless steel or painted in white (RAL 9003) or black (RAL 9005). The model has four shelves with 16 cm inbetween the shelves. Also, the legs are adjustable.

Metos	Code	Dimensions mm
Stand for glasses round	2025319	Ø 550x600
Stand for glasses rectangular	4321234	650x450x410
CUPPI-I s/s	4321252	600x450x600
CUPPI-II s/s	4321250	600x600x600
CUPPI-I white	4321256	600x450x600
CUPPI-II white	4321254	600x600x600
CUPPI-I black	4321260	600x450x600
CUPPI-II black	4321258	600x600x600



Metos rectangular stand for glasses and cups



Metos stand for glasses and cups



Metos CUPPI-I white



Metos CUPPI-II s/s



Metos CUPPI-I black

# METOS PROFF REFRIGERATION AND DISPENSING EQUIPMENT



**Metos Proff** refrigeration equipment and Proff Hot dispensing equipment are designed to meet the wide range of our customer needs. Proff products bring to the professional kitchen flexibility, user-friendliness and optimal compatibility between fixtures and equipment. Metos Proff is a series of easy-to-clean, hygienic and ergonomic fixtures and equipment. The range of stainless steel tops is extensive, which makes a high level of customization possible. All Proff equipment can also be designed according to customer needs.

Applications include drawers for beverages, soft drinks, beers and wines. There are drawers for GN containers of different heights for the storage of food ingredients. The smoothly gliding telescopic runners can be removed for cleaning without tools. One intermediary shelf or set of runners

comes standard. The bain-maries have precision electronic temperature control. The sturdy adjustable legs are easy to clean. Proff units can also be equipped with castors.

The efficient and reliable Metos refrigerator cassette model can be serviced quickly. The condenser is conveniently cleaned at the front. The proven reliability of the refrigerator has naturally been one of the fundamentals in its design. Temperature range of the refrigerated units is +4...+15°C, when ambient temperature is +32°C and relative humidity 60%. The cooling agent is R404A. If needed, Proff refrigeration units can be connected to a central refrigeration unit.

The Proff range features a pleasantly rounded front end and especially the handle that is ergonomic and easy to clean.



# METOS PROFF REFRIGERATION AND DISPENSING EQUIPMENT



Renewed sealing



Embedded operating panel



Table tops with basin



Saladette



Cold cupboards



Heated cupboards



Pizza counters



Drawers cold/heated



Dispensing solutions



## METOS PROFF COLD DRAWER CUPBOARDS FOR GN CONTAINERS

**Metos Proff cold drawer** cupboards for GN containers. The drawers have smooth-moving telescopic guiderails on rollers. The continuous structure with rounded edges is ergonomic and easy to keep clean. The cold air flow is distributed evenly throughout the unit. Electronic control system and large digital temperature display. All units have a powerful pull-out cassette refrigeration unit. The capacities of the standard products presented here are as follows:

NT-800-GN3-MGH: 4 pcs GN1/1-15 drawers.  
 NT-1200-GN3-MGH-GN3: 7 pcs GN1/1-150 drawers.  
 NT-1200-GN4-MGH-GN4: 8 pcs GN1/1-100 and 1 pc GN1/1-150 drawers.  
 NT-1600-GN3-GN3-MGH-GN3 10 pcs GN1/1-150 drawers.  
 NT-2000 -GN3-GN3-MPL-GN3 -GN3 12 pcs GN1/1-150-drawers  
 Electric connection 230V1~0,5 kW 10A. GN containers are not included.

Cold drawer	Code	Dimensions mm
NT-800-GN3-MGH	4321000	800x650x900
NT-1200-GN3-MGH-GN3	4321002	1200x650x900
NT-1200-GN4-MGH-GN4	4321004	1200x650x900
NT-1600-GN3-GN3-MGH-GN3	4321006	1600x650x900
NT-2000 -GN3-GN3-MPL-GN3-GN3	4321008	2000x650x900



Metos Proff NT-1200 for nine GN1/1 containers. 4321004 pictured.

## METOS PROFF GRILL DRAWER CUPBOARDS

**Metos Proff GR** grill drawer cupboards for GN containers. The height of the unit is 650 mm. The top is well insulated thermally, which prevents the heat from the warm grill equipment from being conducted into the cold space. The drawers have smoothly moving telescopic guiderails with rollers. The uniform construction with rounded edges is ergonomic and easy to keep clean. Cold air is blown evenly throughout the unit. Electronic control and large digital temperature display. All units have a powerful pull-out cassette refrigeration unit. The capacities of the models presented here are as follows:

GR-800-GN2L-ML 2 pcs GN1/1-150 drawers.  
 GR-1200-GN2L-ML-GN2L 4 pcs GN1/1-150 drawers.  
 GR-1600-GN2L-GN2L-ML-GN2L 6 pcs GN1/1-150 drawers.  
 Electric connection 230V1~0,5 kW 10A. GN containers are not included.

Grill drawer	Code	Dimensions mm
GR-800-GN2L-ML	4321030	800x650x650
GR-1200-GN2L-ML-GN2L	4321032	1200x650x650
GR-1600-GN2L-GN2L-ML-GN2L	4321034	1600x650x650



Metos Proff GR-1600 grill drawer cupboard (grill equipment not included). 4321034 pictured.

## METOS PROFF BEVERAGE DRAWER CUPBOARDS

**Metos Proff NT beverage drawer** cupboards have smoothly moving telescopic guiderails on rollers and central locking as standard. The uniform construction with rounded edges is ergonomic and easy to keep clean. The efficient cold air blow is distributed throughout the unit. Electronic control and large temperature display. All models have an efficient pull-out cassette refrigeration unit. The capacities of the models presented here are as follows:

NT-800-BO2-MBO: 3 drawers for beverage crates (2 for wine bottles)  
 NT-1200-BO2-MBO-BO2: 5 drawers for beverage crates (4 for wine bottles)  
 NT-1600-BO2-MBO-BO2: 7 drawers for beverage crates (6 for wine bottles)

Electric connection 230V1~0,5 kW 10A.

Beverage drawer	Code	Dimensions mm
NT-800-BO2-MBO	4321010	800x650x900
NT-1200-BO2-MBO-BO2	4321012	1200x650x900
NT-1600-BO2-BO2-MBO-BO2	4321014	1600x650x900



Metos Proff NT-1200 for five beverage crates. 4321012 pictured.





## METOS PROFF BOTTLE BASINS



Metos Proff BT-1200 bottle basin with cold cupboards. 4321042 pictured.

**Metos Proff BT bottle basins** come in standard dimensions. The basin depth is 160 mm. The uniform rounded-edge construction is ergonomic and easy to keep clean. The efficient cold air blow is distributed throughout the unit. Electronic control and large temperature display. All models have an efficient pull-out cassette refrigeration unit.

Proff hand out shelves and upper shelves on page 80. Hand out shelves and upper shelves which are build with the unit, must be ordered with the unit.

The capacities of the models presented here are as follows:

BT-400-MPL: basin GN1/1  
 BT-800-DSL-MPL: basin GN2/1, left-hand cupboard  
 BT-1200-DSL-MPL-DSR: basin GN3/1, left- and right-hand cupboards

Electric connection 230V1~0,5 kW 10A.

Bottle basin	Code	Dimensions mm
BT-400-MPL	4321038	400x650x900
BT-800-DSL-MPL	4321040	800x650x900
BT-1200-DSL-MPL-DSR	4321042	1200x650x900
GN-rail pair	4321308	
Grid shelf	4188723	
Stainless steel shelf	4188748	

## METOS PROFF SALADETTE



Metos Proff STH-1200 saladette, the protective cover is standard, GN containers and cutting board are optional extras. 4321052 pictured.

**Metos Proff STH saladette** is ergonomic and easy to keep clean. The efficient cold air blow is distributed throughout the unit. Electronic control and large temperature display. All models have an efficient pull-out cassette refrigeration unit. The cooled rear edge space for GN containers raised and inclined forward. This way ergonomics is improved. GN container space is dimensioned for GN 1/3-150 containers. The protective cover is standard.

The capacities of the standard products are as follows:

STH-800-GN3-MGH: 2xGN1/3, GN1/1-150 drawers 4 pcs.  
 STH-1200-GN3-MGH-GN3: 3xGN1/3, GN1/1-150 drawers 7 pcs.  
 STH-1600-GN3-GN3-MGH-GN3: 4xGN1/3, GN1/1-150 drawers 10 pcs.  
 Electric connection 230V1~0,5 kW 10A. GN containers and cutting board are not included.

Saladette	Code	Dimensions mm
STH-800-GN3-MGH	4321050	800x650x1021
STH-1200-GN3-MGH-GN3	4321052	1200x650x1021
STH-1600-GN3-GN3-MGH-GN3	4321054	1600x650x1021



Metos Proff bar unit covered with coloured laminates, glass shelf on top.

# METOS PIZZAPROFF PIZZA COUNTER



Metos Pizzaproff pizza counter

**Metos Pizzaproff** pizza counter can be installed within a food preparation line on customer premises. GN-dimensioned cold ingredient basin at the back of the counter.

Below there is a cupboard and 7 GN1/1-150 drawers (PT1200) or 10 GN1/1-150 drawers (PT1600). The GN containers are optional.

A flour collector can be ordered as an additional accessory which is placed at the edge of the table top on the drawer side. Thanks to the flour collector, all left over flour can be cleaned and collected from the table top without messing up the floor.

PizzaProff	Code	Dimensions mm	El. connection
PT1200	4321082	1200x800x900/1021	230V1~0,7 kW
PT1600	4321084	1600x800x900/1021	230V1~0,7 kW
Flour collector	4321090		



## METOS PROFF BAR COUNTER

**Metos Proff BA** bar counter top has a raised basin for ice/bottles and an inclined recess for bottles with drain. The drawers have smoothly moving telescopic guide rails on rollers and central locking as standard. The uniform construction with rounded edges is ergonomic and easy to keep clean. The efficient cold air blow is distributed throughout the unit. Electronic control and large temperature display. All models have an efficient pull-out cassette refrigeration unit.

The capacities of the models presented here are as follows:

BA-800-BO2-MPL: 2 drawers for beverage crates.  
 BA-1200-BO2-BO2-MPL: 4 drawers for beverage crates.  
 BA-1600-BO2-BO2-BO2-MPL: 6 drawers for beverage crates.  
 Electric connection 230V1~0,5 kW 10A.

Bar counter	Code	Dimensions mm
BA-800-BO2-MPL	4321070	800x650x900/950
BA-1200-BO2-BO2-MPL	4321072	1200x650x900/950
BA-1600-BO2-BO2-BO2-MPL	4321074	1600x650x900/950



Metos Proff BA-1200 bar counter

## METOS PROFF COLD COUNTERS

**Metos Proff cold counter** is table-type and horizontal. Each cupboard has an adjustable grated shelf. Above the refrigeration unit is a place for optional drawer for GN1/1-150 containers. The uniform construction with rounded edges is ergonomic and easy to keep clean. Efficient cold air flow is distributed evenly throughout the unit. Electronic control and large temperature display. All models have an efficient pull-out cassette-type refrigeration unit.

The capacities of the standard models presented here are:

NT-800-DSL-MPL 1 section  
 NT-1200-DSL-MPL-DSR 2 sections  
 NT-1600-DSL-DSL-MPL-DSR 3 sections

Electric connection 230V~0,5 kW 10A. GN containers not included.

Cold counter	Code	Dimensions mm
NT-800-DSL-MPL	4321020	800x650x900
NT-1200-DSL-MPL-DSR	4321022	1200x650x900
NT-1600-DSL-DSL-MPL-DSR	4321024	1600x650x900
GN-rail pair	4321308	
Grid shelf	4188723	
Stainless steel shelf	4188748	



Metos Proff NT-1600 cold cupboard with optional drawer above the refrigeration unit.

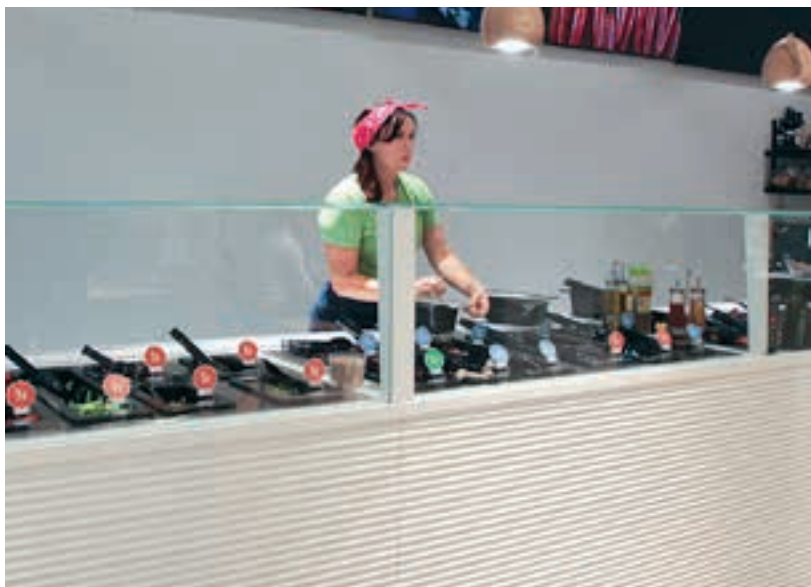



# METOS PROFF HEATED COUNTERS



Metos Proff WT-1200 heated counter (NB. Standard model is with adjustable feet. Castors are optional extra). In WTG-model there is a heated ceramic plate instead of stainless steel in the top.

**Metos Proff heated counters** standard sizes are 400, 800 and 1200 mm. Counter with a heated top, underneath a heated cupboard that contains guide rails for GN containers. One cupboard section fits five GN1/1-100 containers and cupboard under the control panel has capacity for 3 GN 1/1-100 containers. The section doors have sealing. The cupboard temperature can be set with a thermostat at the desired level between 40 and 80 °C. The temperature of stainless steel top is 40 - 70°C. The temperature of WTG glass ceramic counters can be set with a thermostat between 40 - 90 °C. The uniform construction with rounded edges is ergonomic and easy to keep clean.

The electric connection:

WT-400 230V1~1,1 kW 16A  
 WT-800 230V1~0,8 kW 16A  
 WT-1200 230V1~1,41 kW 16A

WTG-800 230V1~1,1 kW 16A  
 WTG-1200 230V1~2,0 kW 16A  
 NTW-800 230V1~0,3 kW 16A  
 NTW-1200 230V1~0,6 kW 16A

GN containers are optional.

Heated unit with heated top	Code	Dimensions mm
WT400-TDRR	4321640	400x650x900
WT-800-DRLW-TDRR	4321642	800x650x900
WT-1200-DRLW-DRLW-TDRR	4321644	1200x650x900
WTG-800-TDRL-TDRR	4321652	800x650x900
WTG-1200-TDRL-TDRL-TDRR	4321654	1200x650x900

Heated unit with neutral top	Code	Dimensions mm
NTW-800-DRLW-TDRR	4321662	800x650x900
NTW-1200-DRLW-DRLW-TDRR	4321664	1200x650x900

Proff castors	Code
Castors 100 mm	4321300

Please order castors together with the counter.

# METOS PROFF HEATED DRAWERS

**Metos Proff heated drawers** sizes are 800 and 1200 mm. Counter with a heated or a neutral top, underneath heated drawers with frames for GN containers. The drawers have sealing. The drawer temperature can be set with a thermostat at the desired level between 40 and 80 °C. The temperature of heated top is 40-70°C. The uniform construction with rounded edges is ergonomic and easy to keep clean.

The electric connection:

800 230V1~0,8 kW 16A 5x GN1/1-150  
 1200 230V1~1,41 kW 16A 8x GN1/1-150

GN containers are optional.



Metos Proff WTW-1200 heated drawer

Heated drawer with heated top	Code	Dimensions mm
WTW800-GN3-GN3(2)	4321646	800x650x900
WTW1200-2xTGN3-TGN3(2)	4321648	1200x650x900

Heated drawer with neutral top	Code	Dimensions mm
NTW800-GN3-GN3(2)	4321666	800x650x900
NTW1200-2xTGN3-TGN3(2)	4321668	1200x650x900

Proff castors	Code
Castors 100 mm	4321300

Please order castors together with the counter.



# METOS PROFF BAIN-MARIES



Metos Proff BM-1200 bain-marie, code 4321604.

**Metos Proff bain-marie** sizes are 400, 800 and 1200 mm. The base houses a heated cupboard with guide rails for GN containers. One cupboard section will fit three GN1/1-100 containers. The bain-marie is thermally insulated. The cupboard doors have sealing. The temperature can be set with a thermostat. The basin construction is seamless and has a drain faucet. The uniform construction with rounded edges is ergonomic and easy to clean. The basin depth is 210 mm. Proff hand out shelves and upper shelves on page 80. Hand out shelves and upper shelves which are build with the unit, must be ordered with the unit.

Electric connection:

BM-400 230V1~1,1 kW 16A

BM-800 230V1~1,4 kW 16A

GN containers are optional.

BM-1200 230V1~2,25 kW 16A

BM-1600 230V1~2,25 kW 16A

Bain-marie	Code	Dimensions mm
BM-400-TDRR	4321600	400x650x900
BM-800-TDRL-TDRR	4321602	800x650x900
BM1200 3xTDR	4321604	1200x650x900
BM1600 4xTDR	4321606	1600x650x900
BM-F-1*	4321617	Filling for 1 basin

\*Order together with the counter

Bain-marie with one sided upper part	Code	Dimensions mm
BM800-TDRL-TDRR-US1H	4321608	800x650x900
BM1200-TDRL-TDRL-TDRR-US1H	4321610	1200x650x900



Metos Proff BM3-1200 bain-marie with separate basins, code 4321616.

**Metos Proff BM2 and BM3 bain-maries** are similar to Proff BM bain-maries, but they are fitted with separate GN1/1 dimensioned basins. Each basin has efficient temperature control and drain faucet. The basin corners are rounded for easier cleaning. The basin depth is 210 mm. The cupboard section has one heating.

Electric connection:

BM2-800 230V1~1,4 kW 16A

BM3-1200 230V1~2,25 kW 16A

GN containers are not included.

BM4-1600 230V1~2,25 kW 16A

Bain-marie	Code	Dimensions mm
BM2-800-TDRL-TDRR	4321614	800x650x900
BM3-1200 3xTDR	4321616	1200x650x900
BM4-1600 4xTDR	4321612	1600x650x900
BM-F-2*	4321618	Filling for 2 basins
BM-F-3*	4321619	Filling for 3 basins

\*Order together with the counter



# METOS PROFF BAIN-MARIES WITH OPEN STAND

**Metos Proff open stand bain-marie** sizes are 400, 800 and 1200 mm. The bain-marie has an open stand. The bain-marie is thermally insulated. The temperature can be set with a thermostat. The basin construction is seamless and has a drain faucet. The uniform construction with rounded edges is ergonomic and easy to clean. The basin depth is 210 mm. Proff hand out shelves and upper shelves on page 80. Hand out shelves and upper shelves which are build with the unit, must be ordered with the unit.

The Proff bain-maries with open stand can be fitted with filling faucets. BM-F-1, BM-F-2 and BM-F-3 operate by push-buttons., separate filling faucet for each basin. Push-buttons are handy situated in the front of each basin in the panel.

BM-HF is a hands hower which can be used for filling the basin or for washing the counter. When the hand shower and the hose are not in use, they are placed onto a shelf of the stand, where is a hook for the shower.

These optionals are only available for the open stand models BMOS and BMC.

Electric connection:

BMOS-400 230V1~0,55kW 16A      BMOS-1200 230V1~1,65kW 16A  
 BMOS-800 230V1~ 1,1kW 16A      BMOS-1600 230V1~1,65kW 16A

GN containers are not included.



Metos Proff BMOS-1200 bain-marie with open stand (code 4321624) and optional hand shower.

Bain-marie	Code	Dimensions mm
BMOS-400	4321620	400x650x900
BMOS-800	4321622	800x650x900
BMOS-1200	4321624	1200x650x900
BMOS-1600	4321626	1600x650x900
BM-F-1*	4321617	Filling for 1 basin
BM-HF*	4321628	Handshower in the stand

\*Order together with the counter

**Metos Proff BMOS2 and BMOS3 bain-maries** are similar to Proff BMOS bain-maries, but they are fitted with separate GN1/1 dimensioned basins. Each basin has efficient temperature control and drain faucet. The basin corners are rounded for easier cleaning. The basin depth is 210 mm.

Electric connection:

BMOS2-800 230V1~1,1kW 16A      BMOS4-1600 230V1~1,65kW 16A  
 BMOS3-1200 230V1~ 1,65kW 16A

GN containers are not included.



Metos Proff BMOS3-1200 bain-marie with separate GN 1/1 basins (code 4321632) and optional filling function.

Bain-marie	Code	Dimensions mm
BMOS2-800	4321630	800x650x900
BMOS3-1200	4321632	1200x650x900
BMOS4-1600	4321634	1600x650x900
BM-F-2*	4321618	Filling for 2 basins
BM-F-3*	4321619	Filling for 3 basins
BM-HF*	4321628	Handshower in the stand

\*Order together with the counter



## METOS PROFF UPPER SHELF



Metos Proff upper shelf with double-sided sneeze guard.

**Metos Proff upper shelves** are of stainless steel. The sneeze guard is of hardened glass. Shelf width is 280 mm. The range includes one and two sided shelves with either fluorescent tube lighting (L) or a Halotherm heat radiator (H). Proff upper shelves are always ordered together with a Proff fixture.

Upper shelf with lighting	Code	Dimensions mm	kW
US-800-1L	4321690	800x507x410	0,018
US-800-2L	4321692	800x507x410	0,018
US-1200-1L	4321694	1200x507x410	0,03
US-1200-2L	4321696	1200x507x410	0,03
US-1600-1L	4321697	1600x507x410	0,03
US-1600-2L	4321699	1600x507x410	0,03

Upper shelf with heat radiator	Code	Dimensions mm	kW
US-800-1H	4321680	800x507x410	0,4
US-800-2H	4321682	800x507x410	0,4
US-1200-1H	4321684	1200x507x410	0,6
US-1200-2H	4321686	1200x507x410	0,6
US-1600-1H	4321687	1600x507x410	0,6
US-1600-2H	4321689	1600x507x410	0,6

## METOS SKY UPPER SHELF



Metos Proff Sky Halotherm upper shelf with turning front glass and one sneeze guard.

**Metos SKY upper shelves** are of stainless steel. The shelf and sneeze guard are of hardened glass. Shelf width is 300 mm. The range includes model with LED lightning (LED) and sneeze guards on both sides or Halotherm heat radiator (HFG) with turning front glass and one sneeze guard. Sky upper shelves are always ordered together with a Proff fixture.

Upper shelf with LED lighting	Code	Dimensions mm	kW
800 Proff Sky-LED	4321710	750x560x400	0,03 kW
1200 Proff Sky-LED	4321712	1150x560x400	0,03 kW

Upper shelf with heat radiator	Code	Dimensions mm	kW
800 Proff Sky-HFG	4321702	750x560x400	0,4 kW
1200 Proff Sky-HFG	4321706	1150x560x400	0,6 kW

Accessories	Code	Dimensions mm
End glass 800/1200	4321714	475x350

## METOS PROFF HAND OUT SHELF

**Metos Proff hand out shelves** are of stainless steel and hardened glass. The glass parts are easy to remove for cleaning. HSR is a separate model for retro-installation. HS model is fixed. Order together with Proff fixture.

Metos	Code	Dimensions mm
HSR-800	4305026	795x210x300
HSR-1200	4305029	1195x210x300
HS-800	4305025	795x210x300
HS-1200	4305028	1195x210x300
HS-1600	4305027	1595x210x300



The Metos Proff hand out shelf has a glass shelf and a glass front panel



# METOS PROFF PLATE DISPENSERS



Metos PDW plate dispenser

**Metos Proff PDW plate dispensers** take approximately 130 plates of max. diameter 270 mm. The dispenser has a stepless temperature regulation and easily adjustable spring pressure. The temperature adjustment range is 20-80°C. Proff PD model is similar to PDW but has no heating. Proff PDWT and PDT models are similar models with castors and handle.

Proff LPDW plate dispensers take approximately 65 plates of max. diameter 320 mm. The dispenser has a stepless temperature regulation and easily adjustable spring pressure. The temperature adjustment range is 20-80°C. Proff LPD model is similar to LPDW but has no heating.

Proff LPDWT and LPDT models are similar models with castors and handle.

All models can be fitted with optional adjustment bars for adjusting plate diameter. The cover helps keeping the plates warm and keeps the plates protected from dirt when storing.



Metos	Code	Dimensions mm	El. connection
<b>130 pcs max Ø 270 mm:</b>			
PD	4203900	400x650x900	- neutral
PDW	4203902	400x650x900	230V 1~ 0,7 kW heated
PDT	4203904	400x650x900	- neutral, castors, handle
PDWT	4203906	400x650x900	230V 1~ 0,7 kW heated, castors, handle

<b>65 pcs max Ø 320 mm:</b>			
LPD	4203908	400x650x900	- neutral
LPDW	4203910	400x650x900	230V 1~ 0,7 kW heated
LPDT	4203912	400x650x900	- neutral, castors, handle
LPDWT	4203914	400x650x900	230V 1~ 0,7 kW heated, castors, handle

#### Accessories

Adjustment bars	4203972	adjustment bars for plate dispenser
Cover	4203979	cover for plate dispenser



Metos WD water dispenser

## METOS PROFF WATER DISPENSER

**Metos Proff WD water dispenser** hourly capacity is 60 litres. The top has a glass dispenser and a sink with a drain for drip water.

Metos Proff WD model is built into a Proff worktable body.

N-models are neutral.

E-models have electronic faucet. There is a sensor for water flow and the dosage can be easily adjusted for the present glass size. This model guarantees high standard of hygiene for water dispensing.

All models can be fitted with water filter unit. The unit is assembled in the factory and it is to be ordered with the dispenser.

Cold	Code	Dimensions mm	El. connection
Proff WD	4213317	400x650x900	230V 1~ 0,5 kW
Proff WD-E	4213319	400x650x900	230V 1~ 0,5 kW

Neutral	Code	Dimensions mm	El. connection
Proff WD-N	4213321	400x650x900	
Proff WD-EN	4213323	400x650x900	230V 1~ 0,1 kW

#### Accessories

Filter unit	4213335	ordered with water dispenser
-------------	---------	------------------------------



Electronic faucet of E-model.

# METOS PROFF GN DIVIDERS FOR BAIN MARIES

**GN dividers** are available as an accessory for the Proff bain maries. Lifting and placing GN containers is facilitated with locking Proff GN-dividers. GN-frame is the most efficient way to prevent containers to move when placed to the basin.

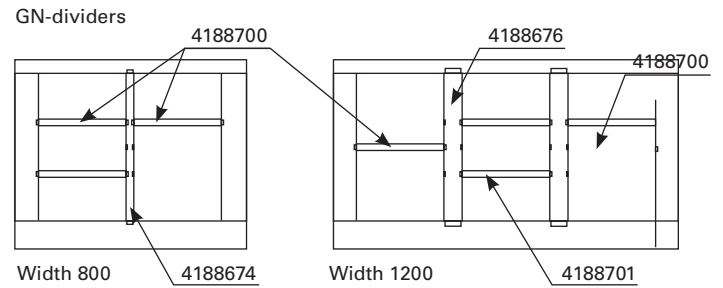

Metos	Code	Dimensions mm
DL800 divider	4188674	554x31, 800 mm basin
DL1200 divider	4188676	554x64, 1200 mm basin
DS divider	4188700	317x20, to the side
DM divider	4188701	310x20, to the middle
GN-divider set 800	4188710	800 basin, incl. 1 pc 4188674 and 3 pcs 4188700
GN-divider set 1200	4188712	1200 basin, incl. 2 pcs 4188676, 3 pcs 4188700 and 1 pc 4188701
GN-frame GN1/1	4136757	325x526
GN-frame 4xGN1/4	4136764	325x526
GN-frame 6xGN1/6	4136762	325x526



GN-divider set 800, code 4188710.



GN-frame GN1/1, code 4136757.



GN-frame 4xGN1/4, code 4136764. Dividers can be easily set to take also different sizes of GN-containers, for example 2xGN1/2.



GN-frame 6xGN1/6, code 4136762. Dividers can be easily set to take also different sizes of GN-containers, for example 3xGN1/3.

# METOS PROFF GN DIVIDERS FOR DRAWERS

**GN divider packages** are available as an accessory for the Proff drawers. With the help of the dividers, it is easy to create and adjust the needed space for the GN trays. All the GN packages contain a frame with package specific dividers. The following spaces can be created with the different packages: 4136772 GN 1/4 and GN 1/2 spaces; 4136774 GN 1/9 spaces and 4136776 GN 1/6 and GN 1/3 spaces.

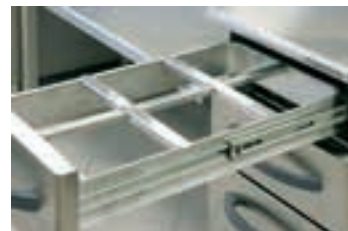

Metos	Code	Dimensions mm	
GN frame GN1/4 and GN1/2	4136772	325x526	for Proff drawer
GN frame GN1/9	4136774	325x526	for Proff drawer
GN frame GN1/6 and GN1/3	4136776	325x526	for Proff drawer



GN frame for Proff drawer, 2xGN1/4 + GN1/2 -containers, code 4136772.



GN frame for Proff drawer, 9xGN1/9 containers, code 4136774.



GN frame for Proff drawer, 4xGN1/6+GN1/3 containers, code 4136776.



# METOS HALO LED OPEN AIR CURTAIN COLD DISPLAYS

**Metos Halo open air curtain cold display** line offers the perfect solution for presenting the products deliciously. The LED lighting under the front edge of the shelf, separate for each shelf, brings your goods out at their best. Open structure helps reaching even the products placed in the back of shelves. Separate basin bottom plates facilitate use and cleaning of the basin.

Well-designed airflow system together with an effective cold unit creates an air curtain in front of the display to ensure right temperatures within the display. The cold airflow is guided to all shelves as well as the basin. The units temperature class is 3M2, when ambient temperature is max +25°C and humidity 60% R.H.

Displays are stainless steel covered and they are available equipped with stainless steel cold cupboards, capacities 800 long model 5x GN1/1-65 and 1200 long models 10x GN1/1-65. Available also with other surface coverings.

Halo displays are designed to fit together with other Metos dispensing units. Models include 800 and 1200mm long versions.

- Air curtain display
- One sided
- Two shelves
- Stainless steel covering
- LED lighting for each shelf and the basin
- Effective cold unit (refrigerant R404a)
- Easy sliding doors on personnel side
- Automatic defrosting
- GN dimensioned basin with airflow to the top and bottom of the container
- Available for remote cooling
- Flat or tube-shaped tray slides are offered as an accessory for the displays

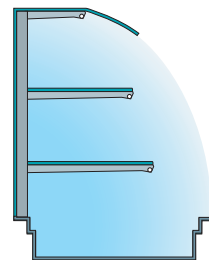

The basin and the shelves of open air curtain display are cold, two shelves.





**Halo LED cold display, open air curtain**

	Code	Dimensions mm	Electric connection
1O800 LED	4312001	800x650x1500	230V1~1,1 kW 16A
1O1200 LED	4312003	1200x650x1500	230V1~1,1 kW 16A

**Halo LED cold display, open air curtain with cold cupboards**

	Code	Dimensions mm	Electric connection
1OC800 LED	4312031	800x650x1500	230V1~1,1 kW 16A
1OC1200 LED	4312033	1200x650x1500	230V1~1,1 kW 16A

# METOS HALO LED ROUNDED COLD DISPLAYS WITH DOORS

**Metos Halo displays** with rounded front give the products the presentation they deserve. The LED lighting under the front edge of the shelf, separate for each shelf, brings the goods out at their best. Displayed products are protected with transparent acrylic doors, which are light and easy to open. All the products will be visible in the whole display thanks to the transparency of the whole upper part. Separate basin bottom plates facilitate use and cleaning of the basin.

Well-designed airflow system together with an effective cold unit ensures that all shelves as well as the basin get their share of cold air. The units temperature class is 3M2, when ambient temperature is max +25°C and humidity 60% R.H.

Displays are stainless steel covered and they are available equipped with stainless steel cold cupboards, capacities 800 long model 5x GN1/1-65 and 1200/1600 long models 10x GN1/1-65. Available also with other surface coverings.

Halo displays are designed to fit together with other Metos dispensing units. Models include 800, 1200 and 1600mm long versions.

- Cold display with doors, handles
- One sided
- Two shelves
- Stainless steel covering
- LED lighting for each shelf and the basin
- Effective cold unit (refrigerant R404a)
- Easy sliding doors on personnel side
- Automatic defrosting
- GN dimensioned basin with airflow to the top and bottom of the container
- Available for remote cooling
- Flat or tube-shaped tray slides are offered as an accessory for the displays

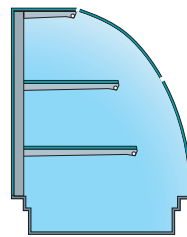

One-sided display with two doors, two shelves

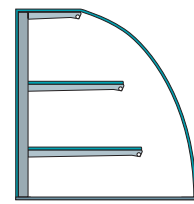

Neutral tabletop display, two shelves





#### Halo LED cold display with doors

	Code	Dimensions mm	Electric connection
1R800 LED	4312101	800x650x1500	230V1~1,1 kW 16A
1R1200 LED	4312103	1200x650x1500	230V1~1,1 kW 16A
1R1600 LED	4312105	1600x650x1500	230V1~1,4 kW 16A

#### Halo LED cold display with doors and cold cupboards

	Code	Dimensions mm	Electric connection
1RC800 LED	4312131	800x650x1500	230V1~1,1 kW 16A
1RC1200 LED	4312133	1200x650x1500	230V1~1,1 kW 16A
1RC1600 LED	4312135	1600x650x1500	230V1~1,4 kW 16A

#### Halo LED tabletop display without basin, neutral

	Code	Dimensions mm	Electric connection
1TR800 LED	4312107	800x650x1500	230V1~0,042 kW 16A
1TR1200 LED	4312109	1200x650x1500	230V1~0,042 kW 16A

# METOS HALO LED SQUARE COLD DISPLAYS WITH DOORS

**Metos Halo displays with square profile** are the best choice when big presentation capacity is needed in a small space. The square looks with straight lines fit the modern interior designs. The LED lighting under the front edge of the shelf, separate for each shelf, brings the goods out at their best. Displayed products are protected with doors, which are light and easy to open. All the products are visible in the whole display thanks to the transparency of the whole upper part. Separate basin bottom plates facilitate use and cleaning of the basin.

Well-designed airflow system together with an effective cold unit ensures that all shelves as well as the basin get their share of cold air. The units temperature class is 3M2, when ambient temperature is max +25°C and humidity 60% R.H.

Displays are stainless steel covered and they are available equipped with stainless steel cold cupboards, capacities 800 long model 5x GN1/1-65 and 1200/1600 long models 10x GN1/1-65. Available also with other surface coverings.

Halo displays are designed to fit together with other Metos dispensing units. Models include 800, 1200 and 1600mm long versions both one and double-sided.

- Cold display with doors, handles
- One sided
- Two shelves
- Stainless steel covering
- LED lighting for each shelf and the basin
- Effective cold unit (refrigerant R404a)
- Easy sliding doors on personnel side
- Automatic defrosting
- GN dimensioned basin with airflow to the top and bottom of the container
- GN dimensioned shelves each with separate airflow
- Available for remote cooling
- Flat or tube-shaped tray slides are offered as an accessory for the displays

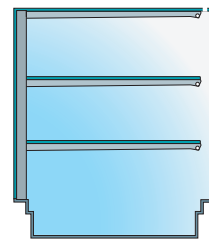

1S = One-sided display with two doors, two shelves

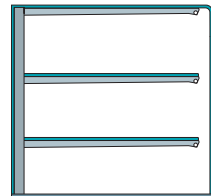

1TS = Neutral tabletop display, two shelves



Square 1200 and 1600 Halo displays have laterally two doors for one shelf

Pictured Halo display case with white Tekno covering (optional)





#### Halo LED cold display with doors

	Code	Dimensions mm	Electric connection
1S800 LED	4312201	800x650x1500	230V1~1,1 kW 16A
1S1200 LED	4312203	1200x650x1500	230V1~1,1 kW 16A
1S1600 LED	4312205	1600x650x1500	230V1~1,4 kW 16A

#### Halo LED cold display with doors and cold cupboards

	Code	Dimensions mm	Electric connection
1SC800 LED	4312231	800x650x1500	230V1~1,1 kW 16A
1SC1200 LED	4312233	1200x650x1500	230V1~1,1 kW 16A
1SC1600 LED	4312235	1600x650x1500	230V1~1,4 kW 16A

#### Halo LED tabletop display without basin, neutral

	Code	Dimensions mm	Electric connection
1TS800 LED,	4312207	800x650x1500	230V1~0,042 kW 16A
1TS1200 LED	4312209	1200x650x1500	230V1~0,042 kW 16A

## METOS HALO ACCESSORIES

Halo LED displays can be fitted with the laminated Nova panels to fit Nova serving line. The standard colours of the laminate are white (K1040), grey (F7912), oak (F2510) and birch (K7024). Special colours and materials are available on request.

Accessories	Code	Dimensions mm	
Nova cover panels 800	4312350	800	white, grey, oak, birch
Nova cover panels 1200	4312352	1200	white, grey, oak, birch
Nova cover panels 1600	4312354	1600	white, grey, oak, birch
Flat tray slide 800	4312304	800	
Flat tray slide 1200	4312306	1200	
Flat tray slide 1600	4312308	1600	
Tube tray slide 800	4312344	800	stainless steel
Tube tray slide 1200	4312346	1200	stainless steel
Tube tray slide 1600	4312348	1600	stainless steel
S/s plinths	4312356	800 display	stainless steel
S/s plinths	4312358	1200 display	stainless steel
S/s plinths	4312360	1600 display	stainless steel
Cold cupboard GN guides	4312310		
Air flow grid	4312362		stainless steel



# METOS CD GLASS DISPLAYS

**Metos CD display** has open bottle basin and glass shelves, each with one door. One powerful lighting device in the top. The spacious display offers a plenty of presentation area.

The CD displays are available at 800 and 1200 mm sizes, both with 2 or 3 shelves. CD 800 has one refrigerated cupboard under the display and CD 1200 has two. Metos CD glass displays have sturdy moulded polyurethane bodies. The coolant is R404a. All visible surfaces are stainless steel. The temperature regulation and defrosting are controlled automatically. The CD display is also available as a neutral counter top display and a model for wall installation with cupboards facing front.

- Powerfull compressor
- Refrigerant R404a
- Refrigerated cupboards
- Stainless steel housing
- Shelf doors
- 2 or 3 shelves
- Counter top displays
- The temperature adjustment range is +4...+9°C.

CD refrigerated display	Code	Dimensions mm	
CD 800-2, 2 shelves, basin, cupboard	4312400	800x650x1490	
CD 800-3, 3 shelves, basin, cupboard	4312402	800x650x1630	
CD 1200-2, 2 shelves, basin, 2 cupboards	4312410	1200x650x1490	
CD 1200-3, 3 shelves, basin, 2 cupboards	4312412	1200x650x1630	

CD counter top display neutral	Code	Dimensions mm	
TD 800-2, 2 shelves	4312420	800x650x590	
TD 800-3, 3 shelves	4312422	800x650x730	

Counter top basket rack	Code	Baskets/ rail distance	Dimensions mm
BAS-2	4554156	2 /195 mm	560x560x600
BAS-3	4554154	3 /195 mm	560x560x850



# METOS PROFF FIXTURES



Proff fixtures offer many practical details and numerous combination possibilities with refrigerated and heated Proff units. Pictured trash cupboard 4204140, table top with waste hole 180 mm 4205633 and corner cupboard 4180410.

**Metos Proff kitchen fixture** range takes you to a new millennium in the field of professional kitchens. The Proff fixture range together with other Proff units provides a unique opportunity to raise your kitchen to a new level of hygiene and ergonomics.

A distinctive feature of the Proff range is the rounded design of the front edge and splash guard. Sturdy handles, made of polypropylene plastic, are easy to clean, as they can withstand all the chemicals used in the kitchen.

You can choose from the Proff standard selection or you can design a Proff unit of your own choosing. Start planning your table unit by selecting the counter top, either 650, 700 or 800 mm. The module dimension of the lower units is 400 mm.

The standard height of the Proff tables is 900 mm, the adjustment range of the legs is + or - 25 mm. The adjustable threads of the pleasant round legs are totally hidden. The square legs are of 40x40 mm stainless steel tube. Proff fixtures are also available with a high base with 250 mm high lower space. The standard splash guard in wash tables is 60 mm high. As an option, a 60-200 mm high splash guard is available.

Please contact your nearest Metos representative or our planning department for your future Proff kitchen.



The seamless counter top is tailor-made to match your need. Below the counter top there is stainless supporting frame with efficient soundproofing.



Wash table with 7mm wash table edge. Standard splash guard in wash tables is 60 mm high, optional splash guard 60-200 mm.



All drawers are fitted with frame for GN containers (containers are optional). The telescopic runners enable the drawers to be pulled out entirely.

# METOS PROFF STANDARD UNITS

**Metos Proff standard table units** comprise counter top and described elements. Standard counter top width is 650 mm. You can also design table units to suit your specific need using the Proff elements presented on the next opening.

Proff work table	Code	Dimensions mm
1200 solid shelf	4180420	1200x650x900
1600 drawer D-1, solid shelf	4180430	1600x650x900
1800 drawers D-3, cupboard CB-1, solid shelf	4180500	1800x650x900
2000 cupboard CB-2, solid shelf	4180480	2000x650x900

Proff wash table	Code	Dimensions mm
1200 basin P520, grid shelf	4180440	1200x650x900
1600 basin P520, drawer D-1, grid shelf	4180450	1600x650x900
1800 basin P520, drawers D-3, grid shelf	4180510	1800x650x900
2000 basin BE55, cupboard CB-2, grid shelf	4180490	2000x650x900

Supplied with splash guard h= 60 mm



Work table 1200,  
code 4180420



Wash table 1200,  
code 4180440



Work table 1600,  
code 4180430



Wash table 1600,  
code 4180450



Work table 1800,  
code 4180500



Wash table 1800,  
code 4180510



Work table 2000,  
code 4180480



Wash table 2000,  
code 4180490

# METOS PROFF STANDARD UNITS

**Metos Proff neutral cupboard** sizes are 400, 800, 1200 and 1600 mm. The cupboards have a middle shelf with an adjustable height. The uniform construction with rounded edges is ergonomic and easy to keep clean. In addition to the standard range Metos Proff NC neutral cupboards can be assembled at your discretion with other Proff units.

Proff low cupboards	Code	Dimensions mm
NC-400/R, 1 door, adjustable shelf	4250130	400x650x900
NC-400/L, 1 door, adjustable shelf	4250131	400x650x900
NC-800, 2 doors, adjustable shelf	4205143	800x650x900
NC-1200, 3 doors, adjustable shelf	4205168	1200x650x900
NC-1600, 4 doors, adjustable shelf	4205175	1600x650x900

Cupboard with gliding doors	Code	Dimensions mm
2 gliding doors, solid shelf	4180460	800x650x900
2 gliding doors, solid shelf	4180470	1200x650x900

Supplied with splash guard h= 60 mm

Corner table	Code	Dimensions mm
solid shelf	4180400	940/940x650x900

Supplied with splash guard h= 60 mm

Corner cupboard	Code	Dimensions mm
left hinged door, solid shelf	4180410	940/940x650x900

Supplied with splash guard h= 60 mm



Metos Proff NC-1200



Cupboard with gliding doors 1200



Corner table



Corner cupboard

## METOS PROFF WORK TABLE

**Metos Proff neutral work table** is 800 mm wide. Rounded edges and uniform construction make table easy to clean. All stainless steel construction and 60 mm high splash guard on the back edge. Three drawers 700x565x158 mm with telescopic runners.

Neutral work table	Code	Dimensions mm
D-3-800	4252210	800x650x900



# METOS PROFF CUPBOARDS

## Proff wall cupboards

Single door	Code	Dimensions mm
HCB-1-700/R shelf	4250140	400x320x700
HCB-1-700/L shelf	4250141	400x320x700
HCB-1-900/R 2 shelves	4250150	400x320x900
HCB-1-900/L 2 shelves	4250151	400x320x900
HCB-1-1100/R 3 shelves	4250160	400x320x1100
HCB-1-1100/L 3 shelves	4250161	400x320x1100
HCBS-1 extra shelf	4204277	400
HCB-1 lock	4204288	
Double door	Code	Dimensions mm
HCB-2 shelf	4204252	800x320x700
HCB-2 2 shelves	4205746	800x320x900
HCB-2 3 shelves	4205753	800x320x1100
HCBS-2 extra shelf	4204284	800
HCB-2 lock	4204428	

## Proff high cupboards

1 door, 4 adjustable shelves	Code	Dimensions mm
FC-1/R	4250170	600x600x2000
FC-1/L	4250171	600x600x2000
FC-1 lock	4204952	
2 doors, 4 adjustable shelves	Code	Dimensions mm
FC-2	4204925	800x600x2000
FC-2	4204932	1200x600x2000
FC-2 lock	4204949	



Wall cupboard HCB-2



High cupboard FC-2



## METOS PROFF CHEF'S WORK STATION

**Metos Chef's work station** has been designed together with one of the leading chefs in Finland. The basic structure is 800 mm wide Proff stainless steel working table with drawers and cupboard underneath. In drawers there is a frame for GN-containers. In cupboard there is a plastic waste bin and the top plate has a waste hole. The collar of waste hole can be easily removed for washing in dishwasher. There is also a wooden holder for knives and a sharpener. On the left side there is foldable side plate.

A wooden cutting plate 600 x 450 x 50 mm and spice rack are standard accessories.

Metos	Code	Dimensions mm
CS800	4204290	800x650x900

Metos Proff chef's work station increases flexibility in restaurant kitchen. It is also a distinguished piece of furniture for public areas.

## METOS PROFF HAND HYGIENE UNIT

The hand hygiene is important in food production. To complete the Proff line, a unit for hand hygiene is available. The cupboard unit comprises a hand wash basin and door with waste paper hole. Inside the cupboard there is a plastic waste paper bin and storage space for detergent and paper towels. The mixer-tap is a single-handle tap or a top hygienic electronic tap operating with a photo cell, thus operating without touching. The unit has a splash guard.

Proff hand wash unit	Code	Dimensions mm	kWh	EUR
HW-400	4204286	400x650x900	-	1711
HWE-400	4204289	400x650x900	0,01	2187



Metos hand hygiene unit

## PROFF COUNTERTOPS

The length of the top is free between 400 and 3900 mm, longer tops on special order.

Proff counter tops	Code	Dimensions mm
Work top 650	4204256	length x 650x900
Work top 700	4204261	length x 700x900
Work top 800	4204264	length x 800x900
Wash table 650	4204266	length x 650x900
Wash table 700	4204271	length x 700x900
Wash table 800	4204274	length x 800x900

Splashback	Code
60-100 mm	4205792
100-200 mm	4205802

Pair of legs	Code
Proff pair of legs	4204275

## Proff elements, 140 mm socle

Shelf cupboards	Code	Dimensions mm
CB-1, 1 door	4204044	400x640x730
CB-2, 2 doors	4204051	800x640x730

With one solid shelf.

Drawers	Code	Dimensions mm
D-1 GN max h 100	4204086	400x640x250
D-2 GN max h 200	4204118	400x640x730
D-3 GN max h 150	4204125	400x640x730
D-4 GN max h 100	4204132	400x640x730

With telescopic runners, frame for GN container

Waste cupboard	Code	Dimensions mm
Waste cupboard 400	4204140	400x640x730

## Low bases, height 140 mm

Base	Code	Dimensions mm
LS-4, width 400	4204157	400x564x140
LS-8, width 800	4204164	800x564x140
LS-12, width 1200	4204171	1200x564x140
LS-16, width 1600	4204173	1600x564x140
LS-20, width 2000	4204175	2000x564x140

round feet, height 140 mm, depth 564 mm

Wheel bases	Code	Dimensions mm
CS 390, width 390	4204189	390x534x140
CS 790, width 790	4204196	790x534x140

height 140 mm, depth 534 mm

## Proff elements, 250 mm socle

Shelf cupboards	Code	Dimensions mm
CBH-1 / R, 1 door	4250110	400x640x620
CBH-1 / L, 1 door	4250111	400x640x620
CBH-2, 2 doors	4205893	800x640x620

With one solid shelf.

Drawers	Code	Dimensions mm
DH-3	4205908	400x640x620

With telescopic runners, frame for GN 2x100 + 1x150 mm

## High bases, height 250 mm

Base	Code	Dimensions mm
LSH-4, width 400	4205915	400x564x250
LSH-8, width 800	4205922	800x564x250
LSH-12, width 1200	4205947	1200x564x250

square feet of 40x40 ss tube

## Proff elements FOR BOTH SOCLE HEIGHTS

Runners	Code	
R-4	4204069	for racks
R-7	4204076	for GN container
RT-3	4205841	for racks
RR-4	4205866	for racks
RR-7	4205859	for GN containers

Shelf, 1 m	Code
S solid shelf	4204213
GS grid shelf	4204238





# METOS PROFF ELEMENTS

## Sinks

Sink	Code	Dimensions mm
K 1	4205224	250x100x125
K 2	4205231	290x155x125
K 314	4205249	335x200x140
K 414	4205256	170x400x140
T 29	4205263	290x400x160

## Wash basin

Wash basin	Code	Dimensions mm
P 314	4205288	335x300x140
P 414	4205295	335x400x140
P 420	4205305	335x400x200
P 425	4205312	335x400x250
P 4420	4205351	400x400x200
P 4425	4205369	400x400x250
P 520	4180932	500x400x200
P 525	4180957	500x400x250
BE 55	4205383	550x500x240
P 620	4182538	600x400x200
P 625	4182545	600x400x250
P 630	4182552	600x400x300
PE 70	4205418	700x440x240
SK 55/25	4180964	550x550x250
P 6528	4205432	600x500x280
P 75525	4205457	700x550x250
P 75530	4205464	700x550x300
P 532, GN basin	4180996	510x305x210
D2714	4204809	ø 270
D3714	4204816	ø 370
D3814	4204823	ø 380

## Accessories

Product	Code
Strainer basket SA212	4181943
Closing valve with filter	4205489
Overflow closing valve	4205496
Siphon for 1 basin	4205506
Siphon for 2 basins	4205513
Flow break	4205538
Connection to dishwasher	4205546
Rack guide for prewash table	4205552
Rack guide	4205577
Lattice bottom valve	4204828
Bevelled end	4205584
Pillar cut-out in corner	4205591
Pillar cut-out in middle	4205601
Corner attachment	4205619
Lowered table top	4205627
Waste hole 240mm, stainless, lid	4180918
Waste hole 180mm, stainless, lid	4205633
Cover plate for stand h 0-200mm x 1m	4205665
Cover plate for stand h 200-300mm x 1m	4205672
Cover plate for stand over 300mm x 1m	4205697
Abloy lock CB-1&CBH-1	4204862
Abloy lock CB-2&CBH-2	4204887
Extra shelf CB-1&CBH-1	4205778
Extra shelf CB-2&CBH-2	4205785
Pull-out shelf 400x600 mm	4205827
Pull-out shelf 800x600 mm	4205834

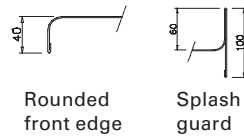

Rounded front edge

Splash guard

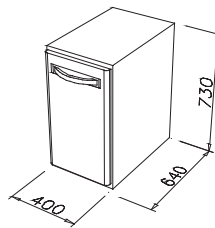

Shelf cupboard CB-1, code 4204044

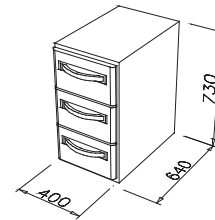

Drawers D-3, code 4204125

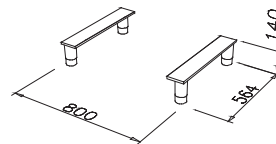

Base LS-8, code 4204164

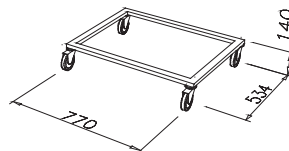

Wheel base CS 790, code 4204196

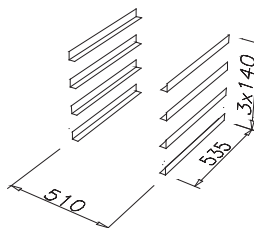

Runners R-4 for racks, code 4204069



# METOS CLASSIC FIXTURES



Metos Classic tables in stainless steel for professional kitchens and restaurants.

**Metos Classic** product range allows you to build specialised constructions to suit just your own kitchen. The units are made of sturdy stainless steel, which is long-lasting and simple to clean.

The standard thickness of the counter top is 1.0 mm. The legs are of 30x30x1 mm tube and the cross and longitudinal supports are of 20x30x1 mm stainless steel tube. A support structure made of square tubes is under the counter top, also of stainless steel. The underside of the table can be washed daily without any damage to the structure. Efficient soundproofing.

Customizing a table unit for your needs is easy. Start by selecting the unit width, either 650, 700 or 800 mm, as well as the total length. If needed, select a sink and specify its location. The counter top can be equipped with a 60-200 mm high splash plate. The desired lower units with a modular size of 400 mm will be installed into the stand. The drawer set, easy to clean, has GN1/1 -65 containers with plastic runners. The shelved cupboards have one shelf as standard. Additional shelves can be ordered as needed. The height of the Classic fixtures is 900 mm and the adjustment range of the legs is + or - 20mm. The base cupboards and drawer sets can also be ordered with casters.

In addition to the work and washing counters you can choose Classic cupboards from the table below. The Classic cupboard range contains low and high floor cupboards and wall-mounted units. In the planning of fixtures you can turn to our local representative or our design department.

<b>Low cupboards</b>	<b>Code</b>	<b>Dimensions mm</b>
MK-400/R	4250035	400x650x900
MK-400/L	4250036	400x650x900
MK-800	4205177	800x650x900
MK-1200	4205178	1200x650x900
MK-1600	4205179	1600x650x900
<b>High cupboards</b>	<b>Code</b>	<b>Dimensions mm</b>
LK-1/R, 1 door	4250075	600x600x2000
LK-1/L, 1 door	4250076	600x600x2000
LK-2, 2 doors	4204929	800x600x2000
LK-2, 2 doors	4204936	1200x600x2000
LK-1 lock	4204919	
LK-2 lock	4204935	
<b>Wall cupboard 400</b>	<b>Code</b>	<b>Dimensions mm</b>
SK 1-700/R - one shelf	4250045	400x320x700
SK 1-700/L - one shelf	4250046	400x320x700
SK 1-900/R - two shelves	4250055	400x320x900
SK 1-900/L - two shelves	4250056	400x320x900
SK 1-1100/R - three shelves	4250065	400x320x1100
SK 1-1100/L - three shelves	4250066	400x320x1100
SK 1 - extra shelf	4150247	400
SK-1 lock	4150251	
SK-2 lock	4150258	
<b>Wall cupboard 800</b>	<b>Code</b>	<b>Dimensions mm</b>
SK 2 - one shelf	4150222	800x320x700
SK 2 - two shelves	4188586	800x320x900
SK 2 - three shelves	4188593	800x320x1100
SK 2 - extra shelf	4150254	800

# METOS CLASSIC FIXTURES

Classic	Code	Dimensions mm
Work top 650	4184535	length x650x900
Work top 700	4184540	length x700x900
Work top 800	4184542	length x800x900
Sink table 650	4184545	length x650x900
Sink table 700	4184550	length x700x900
Sink table 800	4184552	length x800x900

Splashback	Code
60-100 mm	4205792
100-200 mm	4205802

Pair of legs	Code
Classic pair of legs	4184553

Shelf cupboards	Code
H-1	4180756
H-2	4180763
Shelf H-1	4205707
Shelf H-2	4205714

Rails	Code
J-4	4180788
J-7	4180795

Drawers	Code
L-1	4187543
L-3	4180805
L-4	4180837
Trash cupboard	4188040

Wheel base	Code
PA 390 mm	4187575
PA 790 mm	4187092

Cutting board rack	Code
LT	4180876

Shelf	Code
Solid shelf · 1m	4180851
Grid shelf · 1m	4180869

Sink	Code	Dimensions mm
K 1	4205224	250x100x125
K 2	4205231	290x155x125
K 314	4205249	335x200x140
K 414	4205256	170x400x140
T 29	4205263	290x400x160

Wash basin	Code	Dimensions mm
P 314	4205288	335x300x140
P 414	4205295	335x400x140
P 420	4205305	335x400x200
P 425	4205312	335x400x250
P 4420	4205351	400x400x200
P 4425	4205369	400x400x250
P 520	4180932	500x400x200
P 525	4180957	500x400x250
BE 55	4205383	550x500x240
P 620	4182538	600x400x200
P 625	4182545	600x400x250
P 630	4182552	600x400x300
PE 70	4205418	700x440x240
SK 55/25	4180964	550x550x250
P 6528	4205432	600x500x280
P 75525	4205457	700x550x250
P 75530	4205464	700x550x300
P 532, GN basin	4180996	510x305x210



H-1: cupboard 400 mm, H-2: cupboard 800 mm



J-4: rails for four wash racks



J-7: rails for seven GN1/1-65 containers



L-3: three drawers, L-1: one drawer below top



L-4: four drawers



LT: cutting board rack



Wide range of standard sinks



Wash basins with rounded edges

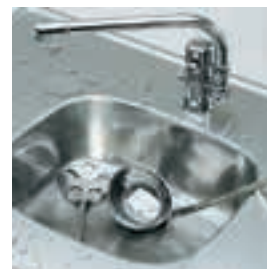

Sinks with rounded edges

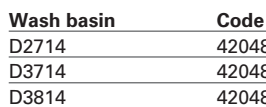

Wash basin	Code	Dimensions mm
D2714	4204809	ø 270
D3714	4204816	ø 370
D3814	4204823	ø 380

Accessories	Code
Strainer basket SA212	4181943
Closing valve with filter	4205489
Overflow closing valve	4205496
Siphon for 1 basin	4205506
Siphon for 2 basins	4205513
Flow break	4205538
Lattice bottom valve	4204828
Connection to dishwasher	4205546
Rack guide for prewash table	4205552
Rack guide	4205577
Bevelled end	4205584
Pillar cut-out in corner	4205591
Pillar cutout in middle	4205601
Corner attachment	4205619
Lowered table top	4205627
Waste hole 180mm, stainless, lid	4205633
Waste hole 240mm, stainless, lid	4180918
Cover plate for stand h 0-200mm x 1m	4205665
Cover plate for stand h 200-300mm x 1m	4205672
Cover plate for stand over 300mm x 1m	4205697
H-1 lock	4204848
H-2 lock	4204855



Strainer basket, rounded construction easy to clean.



Round waste hole with collar

## METOS COMBINED UNITS AND SPECIAL FURNITURE

---



**Metos combined units** are made by combining different elements produced by Metos factories. The elements can be assembled at the factory to match customers requirements. These combined units can be delivered up to 5 m.

The top can include different basins, drop-in units and upper shelves.

Combinations available under one solid top plate include neutral, cold or heated cabinets, drawers and shelves.

The units can be totally stainless steel or front panels can be covered with laminates or be painted. All units can also be designed according to customer needs.



## METOS INSTALLATION WALL

**Metos installation wall** helps to hide and cover all electric and technical connections in the kitchen in a stylish way. Three wall heights for different purposes e.g. room divider. Accessory shelves available to the sides and to the top of the wall.

The wall element is installed on a socle or a pair of legs.

Installation wall elements	Code	Dimensions mm
850	4252315	600x200x850
1150	4252320	600x200x1150
1550	4252325	600x200x1550

Accessories	Code	
Socle	4252330	1 per wall element
Pair of feet	4252335	600x195x400
Support for shelf	4252340	
Top shelf	4252345	600x403
Side shelf		
Upright pair		
Power distribution unit		



## CUPBOARD FOR CLEANING SUPPLIES

Metos	Code	Dimensions mm
SVSK	4150261	800x400x1850
Classic K	4252200	800x600x1850
LKSK	4251000	600x600x2000



**Metos SVSK** cupboard is designed for storage of long-handled cleaning supplies. It is fixed to the wall at a height of approx. 50 cm from the floor. The cupboard bottom and ceiling are open allowing free air circulation. The brush holder is fitted with a fastening device for handles.



**Metos Classic K** cleaning cupboard is for storing supplies. It is fixed to the wall. The cupboard bottom is open and there is a ventilation connection hole on the roof. Standard: wash basin, water mixer, radiator, rack for cloths, three holders for long-handled supplies, brush holder.



**Metos LKSK** cleaning cupboard is for storing supplies. The cupboard bottom, roof and shelves are perforated allowing free air circulation. Socle height 150 mm. Standard: wash basin, 2 shelves, rack for cloths, three holders for long-handled supplies.

# METOS HEIGHT ADJUSTABLE TABLES



Metos height adjustable table is ergonomic. You can choose the right working height of your table by simply pressing a button. The adjustment is from 700 mm to 900 mm.

In many work fases it is important to transfer the arm strength to machines in a correct way. This is possible when the work height is lower than normally. It is recommended to use height adjustable table e.g. when using small kitchen appliances like slicers, in order to prevent any work related arm and shoulder injuries.

The right working height is quickly adjusted thanks to motored mechanism. The construction of the table is of sturdy stainless steel, and all the corners are rounded. The operating switch is within easy reach, yet shielded behind the front edge.

The adjustment limits of Metos height adjustable tables are from 70 cm to 90 cm. With adjustable feet the table is always horizontal position. The table is equipped with a transformer. The motor operates 24V current, so the table is always safe to use. The max loading capacity of the table is 200 kg.

The Metos height adjustable table manual version comes with hydraulic height adjustment. The table can be set in a place where there's no electricity available.

Electrically adjustable table ATE	Code	Dimensions mm	El. connection
ATE700	4136101	700x650x700...900	230V-0,3 kW 10A
ATE1500	4136109	1500x650x700...900	230V-0,3 kW 10A
ATE1900	4136113	1900x650x700...900	230V-0,3 kW 10A
ATE2300	4136117	2300x650x700...900	230V-0,3 kW 10A

Optionals ATE	Koodi	Dimensions mm
Cupboard KH-1/O	4250085	400x560x438
Cupboard KH-1/V	4250086	400x560x438
Cupboard KH-2	4136119	800x560x438
Drawer KL-3	4136120	400x560x438
Drawer L-1	4187543	400x560x187

Electrically adjustable table ATHE	Dimensions mm	El. connection
ATHE1065	1000x650x700...900	
ATHE1265	1200x650x700...900	
ATHE1365	1300x650x700...900	
ATHE1665	1600x650x700...900	
ATHE2065	2000x650x700...900	

Manually adjustable table ATHM	Code	Dimensions mm	El. connection
ATHM1065	4136130	1000x650x700...900	
ATHM1265	4136131	1200x650x700...900	
ATHM1365	4136132	1300x650x700...900	
ATHM1665	4136133	1600x650x700...900	
ATHM2065	4136134	2000x650x700...900	

All Classic accessories can be applied to ATHE and ATHM

Accessories for all models	Code	Dimensions
Splash guard RL / metre	4205792	h = 60 - 100 mm x 1 m
Grid shelf / metre	4180869	
Solid shelf / metre	4180851	



The manual table height adjustment.

# METOS WALL SHELVES

**Metos shelf system** is a flexible way to arrange kitchen shelves according to your specific needs. Shelf intervals steplessly adjustable. Shelf brackets with firm screw fastening. Both solid and grid shelves available.

Shelves are fitted with a rear upstand and the front edge is turned down, which improves steadiness and load capacity. Shelf bracket intervals should be determined according to use.



Metos wall shelves

Solid shelf	Code
580x300mm	4188522
680x300mm	4188547
780x300mm	4150367
880x300mm	4150374
980x300mm	4150381
1080x300mm	4188018
1180x300mm	4150399
1280x300mm	4150409
1380x300mm	4188025
1480x300mm	4150416
1580x300mm	4150423
1680x300mm	4150448
1780x300mm	4150455
1880x300mm	4205048
1980x300mm	4150462

Grid shelf	Code
580x300mm	4188554
680x300mm	4188032
780x300mm	4150487
880x300mm	4150494
980x300mm	4150504
1080x300mm	4188057
1180x300mm	4150511
1280x300mm	4150529
1380x300mm	4188064
1480x300mm	4150536
1580x300mm	4150543
1680x300mm	4150568
1780x300mm	4150575
1880x300mm	4205055
1980x300mm	4150582

Solid shelf	Code
580x400mm	4188258
680x400mm	4188071
780x400mm	4188089
880x400mm	4188096
980x400mm	4188113
1080x400mm	4188138
1180x400mm	4188145
1280x400mm	4188152
1380x400mm	4188177
1480x400mm	4188184
1580x400mm	4188191
1680x400mm	4188219
1780x400mm	4188226
1880x400mm	4205062
1980x400mm	4188233

Grid shelf	Code
580x400mm	4188265
680x400mm	4188272
780x400mm	4188297
880x400mm	4188314
980x400mm	4188321
1080x400mm	4188339
1180x400mm	4188346
1280x400mm	4188353
1380x400mm	4188378
1480x400mm	4188385
1580x400mm	4188392
1680x400mm	4188427
1780x400mm	4188434
1880x400mm	4205087
1980x400mm	4188441

Shelf bracket	Code
280mm	4150342
380mm	4187776
480mm	4187582
515mm, slanting	4187783

Upright	Code
300mm	4150279
600mm	4150286
900mm	4150293
1200mm	4150303
1600mm	4150328
2000mm	4150335

Shelf bracket, stainless steel	Code
270mm	4187585
370mm	4187586

Upright, stainless steel	Code
400mm	4150281
600mm	4150282
1000mm	4150283

Solid shelf for racks	Code
580x520mm	4188459
1080x520mm	4188466
1680x520mm	4188473





# **NORDIEN-SYSTEM**

## Dishroom Equipment



# NORDIEN-SYSTEM DISHWASHING BASKETS 500 x 500 mm



Basket for cups and glasses

- Smooth sides – no water residue
- Diagonal handles – better balance and better grip
- Wide mesh – for better washing results
- Stackable – for safe transportation and storage
- Double wall construction – for strength and stability
- Injection moulded polypropylene
- Suitable for all types of dishwashing machines

Basket for cups and glasses	Code	Glass h	Pc
010G, grey	4550000	70 mm	~30
Service basket, cups/glasses			
050, beige	4550002	70 mm	~30
Basket for flat and deep plates		Plate Ø	
030, blue	4550004	240 mm	18/12
Basket for cutlery			
040, grey	4550006		
Basket for trays			
060, green	4550008		9



Basket for 18 flat or 12 deep plates



Basket for cutlery



Open base guarantees a good wash result.



Service basket for cups and glasses with one low side for easy access to glasses and cups.



Basket for trays

### Compartment basket, grey

Code	Glass Ø	Glass h	Pc	Colour code	
014G	4550010	110 mm	70 mm	16	yellow
015G	4550012	87 mm	70 mm	25	blue
016G	4550014	72 mm	70 mm	36	white
017G	4550016	60 mm	70 mm	49	red
018G	4550018	52 mm	70 mm	64	green

### Compartmented heightening frame

Code	Glass Ø	Pc	Colour	
024G	4550022	110 mm	16	yellow
025G	4550024	87 mm	25	blue
026G	4550026	72 mm	36	white
027G	4550028	60 mm	49	red
028G	4550030	52 mm	64	green

### Compartment basket with one heightening frame

Code	Glass Ø	Glass h	Pc	Colour code	
014G-1-024G	4550032	110 mm	120 mm	16	yellow
015G-1-025G	4550034	87 mm	120 mm	25	blue
016G-1-026G	4550036	72 mm	120 mm	36	white
017G-1-027G	4550038	60 mm	120 mm	49	red
018G-1-028G	4550040	52 mm	120 mm	64	green

### Compartment basket with two heightening frames

Code	Glass Ø	Glass h	Pc	Colour code	
014G-2-024G	4550042	110 mm	170 mm	16	yellow
015G-2-025G	4550044	87 mm	170 mm	25	blue
016G-2-026G	4550046	72 mm	170 mm	36	white
017G-2-027G	4550048	60 mm	170 mm	49	red
018G-2-028G	4550050	52 mm	170 mm	64	green

### Compartment basket with three heightening frames

Code	Glass Ø	Glass h	Pc	Colour code	
014G-3-024G	4550052	110 mm	220 mm	16	yellow
015G-3-025G	4550054	87 mm	220 mm	25	blue
016G-3-026G	4550056	72 mm	220 mm	36	white
017G-3-027G	4550058	60 mm	220 mm	49	red
018G-3-028G	4550060	52 mm	220 mm	64	green



Ridged compartments – no water-marks – no polishing.



Compartment basket is ideal to prevent breakage and scratches during washing, transporting and storing glasses and cups.



Compartmented heightening frame



Compartment basket for glasses with two heightening frames. Note that compartments and frames are very firmly fixed to the basket. For easy handling it is important that the heights of glasses and the basket are as carefully aligned as possible.

## NORDIEN-SYSTEM DISHWASHING BASKETS 500 x 500 mm



Cover for baskets to protect the goods during storage and transport.

Product		Code
Cover for baskets 119	plastic, white	4550062
Drip tray 135	height 50 mm	4550064
Cover grid 154	rilsan coated steel, blue	3054759
Insert for containers 155	stainless steel wire	4550070
Tray grid	stainless steel wire	4550071

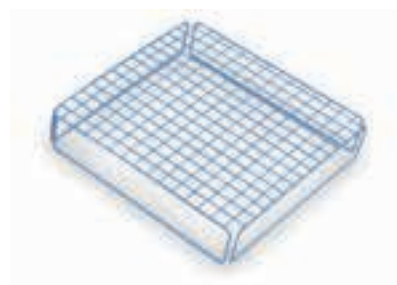

Cover grid to be used when washing lightweight items.



Insert for containers for washing containers and lids placed on edge.



Tray grid



Stainless steel drip tray used with trolleys and tables to prevent dripping on the floor and on table cloths.



### BASKET PRINTING

By a unique system, we can offer printing/coding of baskets. The printing/coding can indicate different glasses, own logo or address and is available in different colours. The printing/coding is ideal for catering and large banquet operations as well as for small restaurants with a large variety of glasses.

**Ask for options.**



Plate cassettes are colour coded.

### PLATE CASSETTES

The cassettes are used in all handling and storage of clean and dirty crockery. They protect the edges of the crockery from becoming chipped during transport and they drastically reduce the crockery breakage. The cassettes can be used in hot cupboards, max 50°C and washed in a dishwashing machine. Height: 30 cm. Made of coated steel wire. Available in eleven sizes.

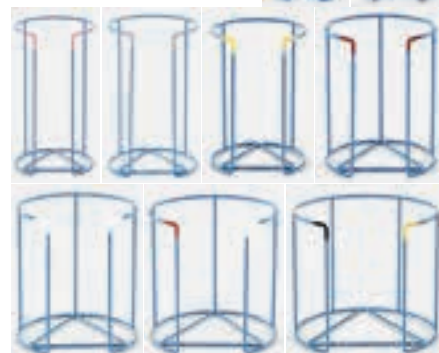

Plate cassettes	Code	Plate Ø	Pcs	Colour
126	4550076	12 cm	45	blue
127	4550078	13 cm	45	black
128	4550080	15 cm	45	pink
129	4550082	17 cm	35	grey
130	4550084	19 cm	30	yellow
131	4550086	22 cm	25	red
132	4550088	25 cm	25	white
133	4550090	28 cm	20	red/white
133A	4550092	32 cm	15-20	black/yellow



We can also supply customer adapted plate cassettes on request.

# THE ONLY DISHWASHING BASKET DEVELOPED WITH THE SERVING STAFF IN MIND

**A glass basket** spends more than 99 % of its time outside the dishwashing machine; that is why it should not be constructed solely for that purpose. Only Nordien-System has paid attention to that fact. For more than 30 years the 460 mm basket system has been developed and improved in closed co-operation with operators all over the world.

Thanks to the smaller dimension of the 460 mm basket, together with round corners and soft edges, the serving staff can carry the basket on their arm, at the same time putting glasses on the tables. The smart construction and the colour options make it possible to use the basket within the restaurant and bar areas.

The 460 mm baskets are ideal in the storage area. The low sides not only enable easy identification but also give a much larger storage capacity as the distance in height between the baskets can be reduced to a minimum and still give easy access to the glasses. The low sides drastically reduce the breakages in the handling-in area.

When the 460 mm basket goes through the dishwashing machine it is placed in an open dishwashing basket (500 mm). When Nordien-System open 500 mm baskets are used the 460 mm basket can be placed tilted for optimum wash and dry result.

1 Dirty goods are being picked up from the tables and carried out to the dishwashing area.

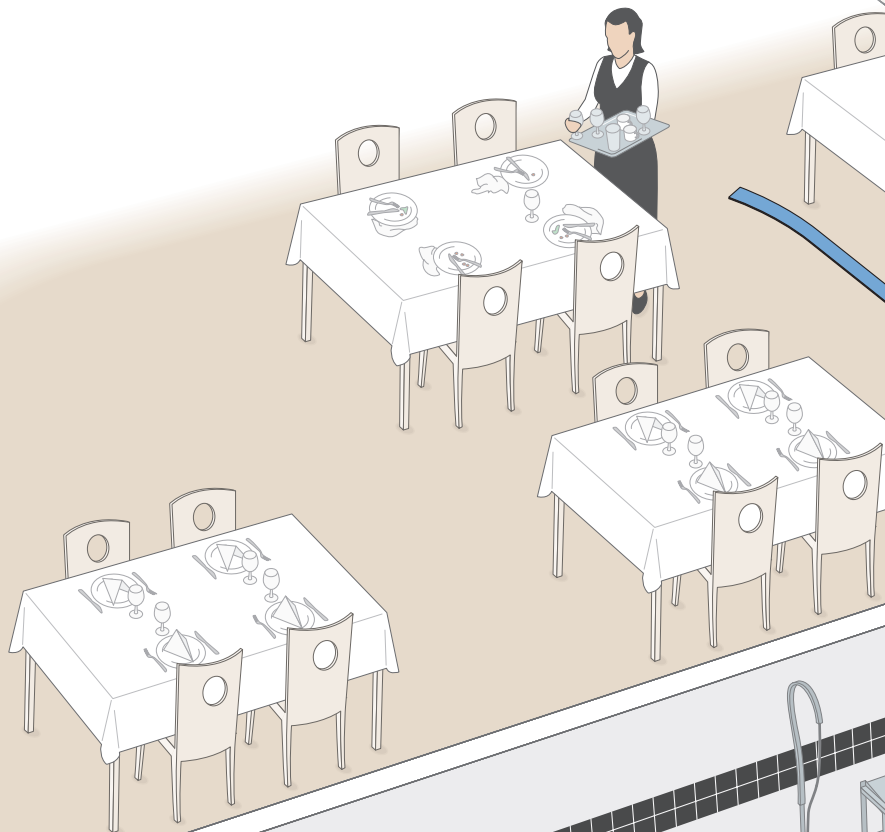

6 The dishwashing process.

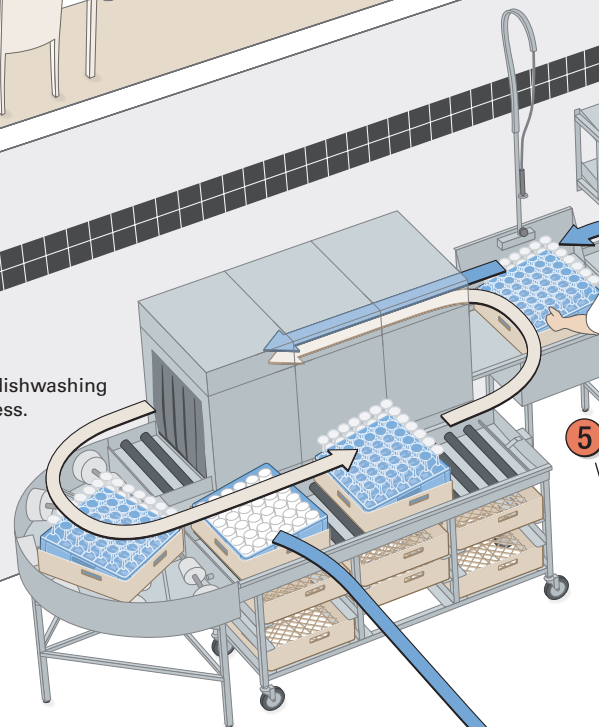

7 Dripping/drying.

The container baskets (in which the 460 x 460 mm baskets are to be placed) are only used in the dishwashing machine. The empty container baskets can be stored under the drying line.



# NORDIEN-SYSTEM DISHWASHING BASKETS 460 x 460 mm

The advantages of the 460 mm system:

- User friendly for both serving and stewarding staff
- Less weight
- Available in 11 different glass compartment diameters for the majority of glasses to fit exactly, minimizing the need for high baskets
- Available in a high version for tall glasses when the diameter of the foot is larger than the bowl
- Coded with different colour codes for each individual compartment size
- Ridged compartments no water marks on the glasses no polishing
- The goods are washed tilted for the best washing and drying result without reduced capacity
- The baskets are washed in a container basket and therefore remain undamaged and unscratched
- Less space required for empty baskets
- A complete system with baskets, trolleys, shelving and tabling
- Used worldwide

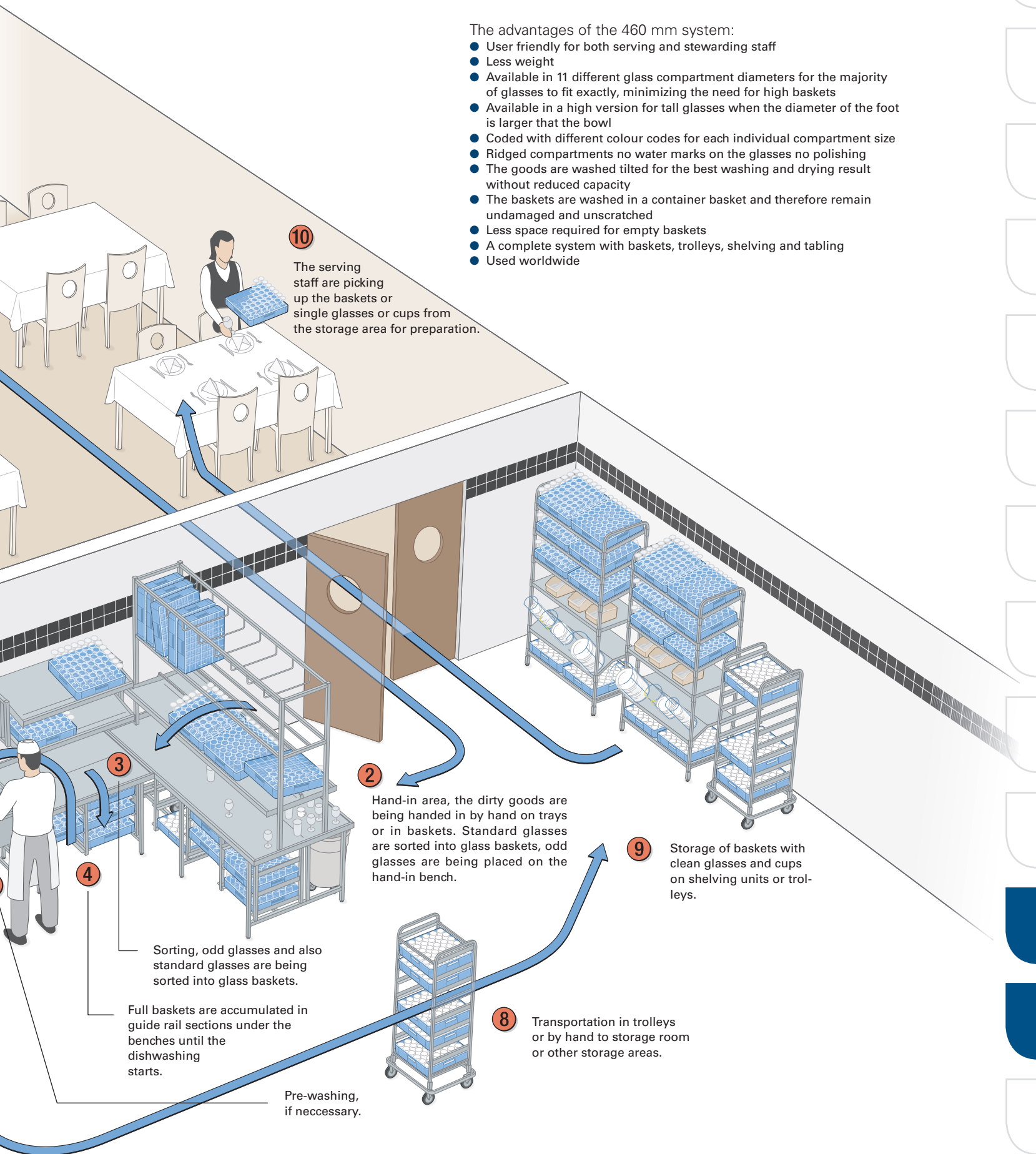

**10** The serving staff are picking up the baskets or single glasses or cups from the storage area for preparation.

**2** Hand-in area, the dirty goods are being handed in by hand on trays or in baskets. Standard glasses are sorted into glass baskets, odd glasses are being placed on the hand-in bench.

**3** Sorting, odd glasses and also standard glasses are being sorted into glass baskets.

**4** Full baskets are accumulated in guide rail sections under the benches until the dishwashing starts.

Pre-washing, if necessary.

**8** Transportation in trolleys or by hand to storage room or other storage areas.

**9** Storage of baskets with clean glasses and cups on shelving units or trolleys.

# NORDIEN-SYSTEM DISHWASHING BASKETS 460 x 460 mm



Compartment basket for glasses and cups The ideal basket for washing, carrying and storing glasses. Each glass is placed in a compartment to prevent breakage and scratches.

- For glasses and cups
- Small dimension with large capacity.
- Light weight – easy handling
- Prior to being placed in the dishwashing machine they are placed at an angle into a 500 x 500 mm basket
- Ridges in the compartments for optimum drying result
- Injection moulded polypropylene

The unique 460 mm compartment basket system from Nordien-System is today used throughout the world. Thanks to its light weight and reduced size (460x460 mm), the serving staff can support the basket on the arm when laying up tables. As the compartment basket is placed in an open 500x500 mm basket for washing it will remain as new without scratches and can therefore also be used in bars and other guest areas. The angle of the basket during washing means that a perfect washing result is obtained and the drying is speeded up.

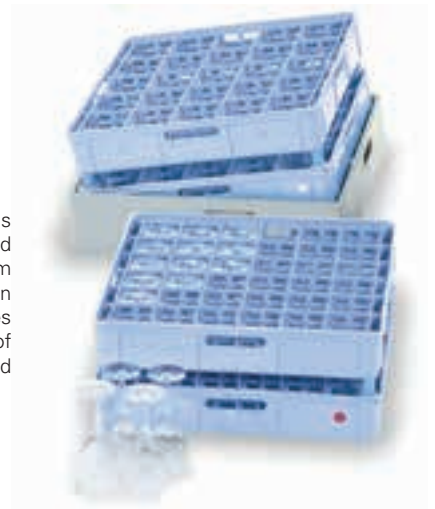

High compartment baskets are for glasses with a larger foot than bowl or very tall glasses.



The picture shows the angle of the basket during washing.

Baskets are colour coded to indicate the glass diameter.

## Compartment basket for glasses and cups, blue

	Code	Glass Ø	Glass h	Pc	Colour code
106	4550094	46 mm	85 mm	81	black
107	4550096	52 mm	85 mm	64	green
108	4550098	56 mm	85 mm	49	grey
109	4550100	60 mm	85 mm	49	pink
110	4550102	65 mm	85 mm	36	red
111	4550104	72 mm	85 mm	36	white
112	4550106	76 mm	85 mm	25	red/yellow
113	4550108	81 mm	85 mm	25	yellow
114	4550110	87 mm	85 mm	25	not coded
115	4550112	95 mm	85 mm	16	white/red
116	4550114	110 mm	85 mm	16	pink/grey
117	4550116	149 mm	85 mm	9	black/white

Ordered in sets of 8 baskets.

High compartment baskets are for glasses with a larger foot than bowl or very tall glasses. When ordering, please state height of glass and the diameter of foot if it is greater than that of the bowl.

Open basket	Code	
103	4550126	blue, height 85 mm

Drip tray for 460 x 460 baskets	Code	
134	4550128	height 50 mm



Open basket

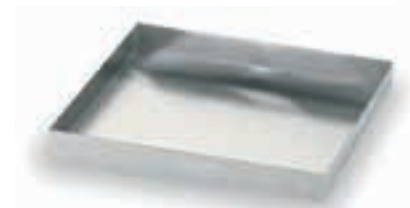

Drip tray in stainless steel, used with trolleys and tables to prevent dripping on the floor and on table cloths.

# CUTLERY HANDLING



Dishwashing tray for cutlery in stainless steel is also suitable for sterile washing.

### Dishwashing tray for cutlery

	Code	Size	Height	Pc
120	stainless steel 4550130	340x160 mm	130 mm	100-150
121	polypropylene 4550132	490x180 mm	140 mm	150 - 200

For soaking and washing cutlery. The dishwashing tray is placed inside basket (code 4550000) when washing.

Cutlery cylinder	Code	Ø	Height	Pc
118	polypropylene 4550134	110 mm	130 mm	40 - 50

For cutlery on server counters and in kitchens. The cutlery cylinder is placed inside basket (code 4550010) when washing.

### Cutlery box for clean cutlery

	Code	Colour	Size	Height	Pc
123	4550136	grey	160x290 mm	130 mm	80 - 120
123B	4550138	blue	160x290 mm	130 mm	80 - 120
123G	4550140	green	160x290 mm	130 mm	80 - 120
123R	4550142	red	160x290 mm	130 mm	80 - 120
123W	4550144	semi-white	160x290 mm	130 mm	80 - 120
123Y	4550146	yellow	160x290 mm	130 mm	80 - 120
124	4550148	brown	160x290 mm	130 mm	80 - 120
125	4550150	beige	160x290 mm	130 mm	80 - 120

polypropylene

### Lid for cutlery box

	Code
156	plexiglass cover for cutlery box 4550153

Lid can easily be put on and taken off. It protects the cutlery against dust and dirt and encourages guests and staff to take the cutlery by the handles.

Stand for cutlery boxes	Size	Height	Code
151	350x295 mm	320 mm	4550154

To hold four Nordien-System's cutlery boxes. Stainless steel.

Wall bracket for cutlery boxes	Length	Code
152-2 for 2 boxes	330 mm	4550160
152-3 for 3 boxes	500 mm	4550162
152-4 for 4 boxes	660 mm	4550164

Stainless steel.

Dishwashing tray for cutlery in polypropylene.



The cutlery cylinders are placed inside compartment basket when washing.



Stand for cutlery boxes



Cutlery box for clean cutlery



Stainless steel wall bracket for cutlery boxes

## NORDIEN-SYSTEM KITCHEN TROLLEYS



**Nordien-System kitchen trolley** assortment provides trolleys for every purpose. The trolleys are sturdy and designed for every day use. All trolleys have stainless steel construction completed with polypropylene guide rails, in trolleys for GN containers also guide rails are steel. The guide rails have basket stops to prevent sliding while moving trolley.

The trolleys are light to push. All trolleys are fitted with ball bearing wheels, two with brakes. Wheel diameter 125 or 75 mm.

Many trolleys are available with options, such as fender to reduce the crockery breakage. Options are to be ordered at the same time with trolley.

Some trolleys have useful accessories to facilitate working, for example additional shelves for basket trolleys.

### FLAT PACK

Most trolleys are available as FLAT PACK versions, which means that trolleys are delivered flat packed unassembled. The trolleys are easy and quick to assemble with instructions and tool included. Small size makes FLAT PACK -models beneficial when transporting.



Flat pack models are easily assembled with instructions and tool included.



The optional fender (to be ordered together with the trolley, not available for flat pack models) makes trolleys resilient and strong.





## TROLLEYS FOR GN CONTAINERS



GNT-7 GN container trolley with s/s top shelf.

**Nordien-System GN container trolleys** can be used to facilitate food preparation, storage and transportation. The trolley construction is sturdy and of stainless steel throughout. The trolleys are fitted with 125 mm ball bearing wheels, two with brakes. The guide rails have basket stops to prevent the containers sliding.

Accessory: s/s top shelf with noise insulation

The GNT-7 trolley has capacity of 7 pcs GN1/1 containers and the GNT-14 trolley 14 pcs GN1/1 containers. Guide rail interval is 75 mm. GNT-12 trolley has capacity of 12 pcs GN1/1 containers and the GNT-24 24 pcs. Guide rail interval is 105 mm.



GNT-14 GN container trolley with s/s top shelf.

Product	Code	Dimensions mm
GNT-7	4554278	410x588x857
GNT-14	4554280	770x588x857
GNT-12	4554282	410x588x1591
GNT-24	4554284	770x588x1591

Accessories	Code	Dimensions mm
S/s top shelf GNT-7/12	4554182	385x565x70
S/s top shelf GNT-14/24	4554184	750x565x70

Flat pack	Code	Package dimensions mm
FP GNT-7	4554374	1255x610x153
FP GNT-14	4554376	1255x610x153
FP GNT-12	4554378	1775x610x153
FP GNT-24	4554380	1775x610x153



Stainless steel top shelf for GNT-14/24 trolleys.



GNT-12 GN container trolley.

GNT-24 GN container trolley.



SHT-90 shelf trolley.



SHT-75 shelf trolley.

## SHELF TROLLEYS

**Nordien-System SHT-75 shelf trolley** is sturdy and of stainless steel throughout. Shelves have a rounded profile rim and noise insulation underneath. Model SHT-90 has plastic grid shelves and stainless steel body. The trolleys are fitted with 125 mm ball bearing wheels, two with brakes. Shelf interval 370 mm. Maximum load 120 kg.

Product	Code	Dimensions mm	Shelves mm
SHT-75	4554286	765x585x1570	4 pcs 730x550
SHT-90	4554288	970x480x1570	4 pcs 900x450

Flat pack	Code	Package dimensions mm
FP SHT-75	4554382	1775x610x153 +1480x645x380
FP SHT-90	4554384	1775x610x153

# SERVICE TROLLEYS



SET-70/2 service trolley.



SET-75/2 service trolley.



SET-75/3 service trolley.

**Nordien-System service trolley** with push-handle is sturdy and of stainless steel throughout. Tiers have a rounded profile rim and noise insulation underneath. The trolleys are fitted with 125 mm ball bearing wheels, two with brakes. Maximum load of 2-tiered trolleys is 80 kg and that of 3-tiered 120 kg.

Option: fender

Accessory: S/S waste bin 2x11 litres with holder and plastic buckets included

Two tiers, interval 495 mm

Product	Code	Dimensions mm	Tiers mm
SET-70/2	4554290	685x485x800*	2 pcs 650x450
SET-75/2	4554292	765x585x800*	2 pcs 730x550
SET-105/2	4554294	1120x585x800*	2 pcs 1085x550

\*handle height 900 mm

Three tiers, interval 230 mm

Product	Code	Dimensions mm	Tiers mm
SET-75/3	4554296	765x585x800*	3 pcs 730x550
SET-105/3	4554298	1120x585x800*	3 pcs 1085x550

\*handle height 900 mm

Options	Code	Dimensions mm
Fender SET-70*	4554172	740x540
Fender SET-75*	4554174	820x640
Fender SET-105*	4554176	1175x640

\*to be ordered with trolley

Accessory	Code	Dimensions mm
S/S waste bin 2x11 litres*	4554190	holder and plastic buckets included
Flat tier SET-70	4554173	
Flat tier SET-75	4554175	

\*photo on page 16

Flat pack	Code	Package dimensions mm
FP SET-70/2	4554386	1480x645x380
FP SET-75/2	4554388	1480x645x380
FP SET-105/2	4554390	1480x645x380
FP SET-75/3	4554392	1480x645x380
FP SET-105/3	4554394	1480x645x380



SET-105/3 service trolley.

## SERVICE TROLLEYS WITHOUT HANDLE

**Nordien-System service trolley** is sturdy and of stainless steel throughout. Tiers have a rounded profile rim and noise insulation underneath. Tier interval is 495 mm, in high models 595 mm. The trolleys are fitted with 125 mm ball bearing wheels, two with brakes. Maximum load 80 kg.

Option: fender

Accessory: S/S waste bin 2x11 litres with holder and plastic buckets included

Height 800 mm, tier interval 495 mm

Product	Code	Dimensions mm	Tiers mm
SET-75WH/2	4554300	765x585x800	2 pcs 730x550

High model, height 900 mm, tier interval 595

Product	Code	Dimensions mm	Tiers mm
SET-75WH/2high	4554302	765x585x900	2 pcs 730x550

**Option**

Code	Dimensions mm
Fender SET-75*	820x640

\*to be ordered with trolley

**Accessory**

Code	Dimensions mm
S/S waste bin 2x11 litres*	holder and plastic buckets included
Flat tier SET-75	4554175

\*photo on page 16

**Flat pack**

Code	Package dimensions mm
FP SET-75WH/2	1480x645x380
FP SET-75WH/2high	1480x645x380



SET-75WH/2 service trolley with a fender.



SET-70/2 wooden service trolley.

## SERVICE TROLLEYS WITH BEECH TIERS

**Nordien-System service trolley** is sturdy and it has stainless steel body. Tiers are of copper beech and fitted with a profile rim of 2 cm. The tier interval of 2-tiered trolleys is 485 mm and that of 3-tiered 220 mm. The trolleys are fitted with ball bearing wheels, two with brakes. Maximum load 80 kg.

Product	Code	Dimensions mm	Tiers beech mm
SET-70/2wooden	4554304	710x445x800*	2 pcs 640x430
SET-70/3wooden	4554306	710x445x800*	3 pcs 640x430

\*handle height 900 mm

**Flat pack**

Code	Package dimensions mm
FP SET-70/2wooden	1480x645x380
FP SET-70/3wooden	1480x645x380



SET-70/3 wooden service trolley.

## KINDERGARTEN TROLLEYS

**Nordien-System handled kindergarten trolley** is sturdy and of stainless steel throughout. Tiers have a rounded profile rim and noise insulation underneath. Tier interval is 300 mm. The handle is at a height of 800 mm. The trolleys are fitted with ball bearing wheels, two with brakes. Maximum load 80 kg.

Product	Code	Dimensions mm	Tiers mm
SET-75/2low	4554308	765x585x600*	2 pcs 730x550

\*handle height 800 mm

**Flat pack**

Code	Package dimensions mm
FP SET-75/2low	1480x645x380



SET-75/2low kindergarten trolley.

## BASKET TROLLEYS FOR 500x500 mm BASKETS



BAT-8 basket trolley with a fender, s/s top shelf and s/s drip tray.



BAS-3 counter top basket rack.



The Dolly without and with handle.

**Nordien-System basket trolleys** for transporting and storing baskets are sturdy, stable and long lasting. Frames are of stainless steel complete with polypropylene guide rails. The guide rails have basket stops to prevent the baskets sliding. The trolleys are fitted with 125 mm ball bearing wheels, two with brakes.

Option: fender

Accessories: Water drip tray, s/s shelf and s/s top shelf

Product	Code	Dimensions mm	Baskets/guide rail distance
BAT-4	4554310	590x590x832	4 baskets/ 160/120mm
BAT-5	4554312	590x590x1072	5 baskets/ 160 mm
BAT-6high	4554480	590x590x1591	6 baskets/ 228 mm
BAT-8	4554314	590x590x1591	8 baskets/ 160 mm

Option	Code	Dimensions mm
Fender BAT*	4554164	645x645

\*to be ordered with trolley

Accessories	Code	Dimensions mm
Water drip tray	4550064	510x510x50
S/S shelf	4554160	510x560x35
S/S top shelf	4554528	565x565x70

Flat pack	Code	Package dimensions mm
-----------	------	-----------------------

FP BAT-4	4554406	1255x610x153
FP BAT-5	4554408	1255x610x153
FP BAT-6high	4554482	1775x610x153
FP BAT-8	4554410	1775x610x153



BAT-4 basket trolley with a fender.



The water-drip tray placed on a basket trolley's lower runners prevents the floor from getting wet and dirty.

## BASKET SERVICE TROLLEY

**Nordien-System basket service trolley** for self service counters etc. Capacity is six baskets. The two upper guide rail sets are angled for easy access to cups and glasses. Frames are of stainless steel complete with polypropylene guide rails. The guide rails have basket stops to prevent the baskets sliding. The trolleys are fitted with 125 mm ball bearing wheels, two with brakes.

Option: fender

Accessories: Water drip tray, s/s shelf

Product	Code	Dimensions mm	Baskets/guide rail distance
BAT-6	4554316	590x590x1596	6 baskets/195 mm

Option	Code	Dimensions mm
Fender BAT*	4554164	645x645

\*to be ordered with trolley

Accessories	Code	Dimensions mm
Water drip tray	4550064	510x510x50
S/S shelf	4554160	510x560x35

Flat pack	Code	Package dimensions mm
-----------	------	-----------------------

FP BAT-6	4554412	1775x610x153
----------	---------	--------------

Counter top basket rack	Code	Dimensions mm	Baskets/guide rail distance
BAS-2	4554156	560x560x617	2 /195 mm
BAS-3	4554154	560x560x870	3 /195 mm



BAT-6 service trolley.

## BASKET DOLLY

**Nordien-System basket dolly** for transporting dishwashing baskets. Trolley and handle of stainless steel. The trolleys are fitted with 125 mm ball bearing wheels, two with brakes.

Product	Code	Dimensions mm	
Dolly	4554346	520x520x205	without handle
Dolly	4554348	565x580x920	with handle

## DISPENSER TROLLEYS



TDT tray dispenser trolley.



Holder for cutlery boxes for TDT and RDT. Cutlery boxes are not included in the delivery.

**Nordien-System dispenser trolley** is used in serving lines for storing glass baskets or trays. The basket dispenser trolley has capacity of five baskets, the tray dispenser trolley approximately 70 trays. The new spring mechanism brings the serving platform always to the right height. The trolleys are of stainless steel. The trolleys are fitted with 75 mm ball bearing wheels, two with brakes.

Option: push-handle

Accessory: holder for plastic cutlery boxes

Product	Code	Dimensions mm
RDT basket dispenser	4554318	515x645x975
TDT tray dispenser	4554320	400x645x975

Options	Code	
Handle*	4554198	handle height 900 mm

\*to be ordered with trolley

Accessory	Code	
Holder for cutlery boxes	4554192	1200 mm*

\*height including cutlery boxes

**Nordien-System TCT tray and cutlery trolley** is sturdy and of stainless steel. Capacity is approx. 100/200 trays. The shelf has a rounded profile rim and noise insulation underneath. The trolleys are fitted with 125 mm ball bearing wheels, two with brakes. The TCT-45 model is fitted with two plastic cutlery boxes, TCT-75 model with four boxes.

Accessories: stainless steel shelf, napkin dispenser

Product	Code	Dimensions mm	Capacity
TCT-45	4554322	425x590x1061	100 pcs
TCT-75	4554324	765x590x1061	200 pcs

Accessories	Code	Dimensions mm
S/S shelf TCT-45	4554186	350x285x60
S/S shelf TCT-75	4554188	690x285x60
Napkin dispenser	4554189	450x320x140

Flat pack	Code	Package dimensions mm
FP TCT-45	4554414	1255x610x153
FP TCT-75	4554416	1255x610x153



RDT basket dispenser trolley with a cutlery box holder.



TCT-75 tray and cutlery trolley.



Hanging napkin dispenser to TCT trolley.

## PLATE CASSETTE TROLLEYS

**Nordien-System plate cassette trolleys** for transport and storage of plates in plate cassettes. Sturdy stainless steel construction. The trolleys are fitted with 125 mm ball bearing wheels, two with brakes.

Option: fender

Product	Code	Dimensions mm	Capacity/shelf interval
PCT-4	4554325	765x415x900	4 dinner plate cass./475 mm
PCT-6**	4554326	1010x415x900	6 dinner plate cass./475 mm
PCT-8	4554328	765x630x900	8 dinner plate cass./475 mm
PCT-12	4554330	765x630x1300	12 dinner plate cass./425mm
PCT-12 low	4554532	1010x630x900	12 dinner plate cass./425mm

\*\*one-sided

Options	Code	Dimensions mm
Fender PCT-4*	4554524	820x470
Fender PCT-6 *	4554168	1065x470
Fender PCT-8/12*	4554166	820x685
Fender PCT-12low*	4554534	1065x685

\*to be ordered with trolley

Flat pack	Code	Package dimensions mm
FP PCT-4	4554522	1480x645x380
FP PCT-6**	4554418	1480x645x380
FP PCT-8	4554420	1480x645x380
FP PCT-12	4554422	1480x645x380
FP PCT-12 low	4554530	1480x645x380

\*\*one-sided



Double sided plate cassette trolley PCT-12 with steel wheels.



Plate cassette trolley PCT-6 with a fender.

# DISH RETURN TROLLEYS AND COMBINATION TROLLEYS

Well organized return of dishes increases customer satisfaction and facilitates the work of kitchen staff. The versatile range of return trolleys enables effective return arrangements even when space is limited.

**Nordien-System dish return trolley** is sturdy and of stainless steel throughout. The trolleys are fitted with 125 mm ball bearing wheels, two with brakes. Two shelves, tray slide and holder for cutlery boxes including 4 plastic cutlery boxes.

Accessory: waste bin (holder and plastic buckets included)

Product	Code	Dimensions mm	Shelves mm
COT-75	4554332	765x585x800/1300	2 pcs 730x550
COT-75low	4554334	765x585x800/1100	2 pcs 730x550

Accessory	Dimensions mm	Code
S/S waste bin 2x11 litres	370x270x325	4554190

Flat pack	Code	Package dimensions mm
FP COT-75	4554424	1480x645x380
FP COT-75low	4554426	1480x645x380



On the left COT-75 dish return trolley with a s/s waste bin and on the right BAT-4 basket trolley.



Stainless steel waste bin 2x11 litres, holder and buckets included.

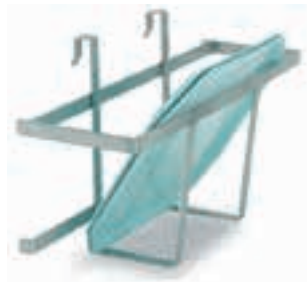

Tray holder for COT-110 and COT-282.



Holder for cutlery tray for COT-110.



Angled plate cassette shelf for COT-110.

**Nordien-System combination trolley** for many uses such as dish return, laying and clearing tables. Stainless steel construction throughout. The trolley is fitted with 125 mm ball bearing wheels, two with brakes. The trolley capacity is five 500 mm or 460 mm baskets. Guide rail distance is 165 mm. Guide rails have basket stops to prevent the baskets sliding. On the right hand side there is a plain shelf as standard, optionally angled plate cassette shelf.

Option: fender

Accessories: additional shelf, tray holder, waste bin (incl. holder and lid), water drip tray, holder for cutlery tray.



COT-110 combination trolley with tray holder, waste bin and fender.

Product	Code	Dimensions mm
COT-110	4554336	1128x590x1089

Option	Code	Dimensions mm
Fender COT-110	4554170	to be ordered with trolley 1185x645

Accessories	Code	Dimensions mm
Plate cassette shelf	4554178	to the right side of trolley 515x560x180
Additional shelf	4554160	to the left side of trolley 510x560x35
Tray holder	4554180	to the left/right side of trolley 570x280x310
Waste bin and holder	4554442	to the left side of trolley 540x210x125
Holder for cutlery tray	4554200	to the left/right side of trolley 540x210x125
Water drip tray	4550064	to the left side of trolley 510x510x50

Flat pack	Code	Package dimensions mm
FP COT-110	4554428	1480x645x380

## DISH RETURN TROLLEYS AND COMBINATION TROLLEYS

**Nordien-System compact combination trolley** for many uses such as laying and clearing tables. Stainless steel construction throughout. The trolley is fitted with 125 mm ball bearing wheels, two with brakes. The capacity is three 500 mm or 460 mm baskets, guide rail distance is 165 mm. Guide rails have basket stops to prevent the baskets sliding.

Accessories: tray holder, waste bin, waste bin holder, water drip tray

Product	Code	Dimensions mm
COT-282	4554338	1120x585x800*

\*handle height 900 mm

Accessories	Code	Dimensions mm
Tray holder	4554180	570x280x310
Waste bin including lid	4554202	310x210x310
Waste bin holder	4554440	
Water drip tray	4550064	510x510x50

Flat pack	Code	Package dimensions mm
FP COT-282	4554430	1480x645x380



COT-282 combination trolley

## DEPARTMENT SERVING TROLLEY



WST Mini with optional side shelf, waste bin holder, hand sanitizer holder and top shelf.

**Nordien-System department serving trolley** has been developed to assist food distribution for instance in a hospital ward. Patient trays are finalized on the trolley by adding cutlery, serviette, etc. Or it can serve as station for afternoon coffee or tea. Trolleys are made of stainless steel. Ball bearing plastic wheels with brakes, diameter 125 mm.

Uniform working platform with ergonomic height. Under the platform there are pull-out tray slides (1 pc WST Mini, 2pcs WST Std/Flex) on both sides and room for 500 x 500 baskets. WST Mini has 2 pairs of pull out guide rails for baskets, WST Std model has 2 + 2 pairs of plastic guide rails for baskets, WST Flex model 2 + 2 pairs of pull out guide rails. Above the trolley on the top frame there is room for GN 1/4 or GN 1/2 containers. Accessories: holder for three 11 liter waste bins, s/s waste bin 2 x 11 liter, plastic side shelf, hand sanitizer holder and a detachable shelf for top frame.

Product	Code	Dimensions mm
WST Mini	4554628	000x000x000
WST Std	4554550	1150x560x1300
WST Flex	4554552	1150x560x1300

Accessories	Code	Dimensions mm
Waste bin holder	4554553	3x11 liter
S/s waste bin	4554554	2x11 liter
Down-fold side shelf	4554555	plastic
Hand sanitizer holder	4554556	
Shelf to top frame	4554557	450 mm

## TRAY RETURN TROLLEYS



TRT-10 tray return trolley.

**Nordien-System tray return trolleys** as single or double models. Standard tray size 430-530 x 325 mm. Frames are of stainless steel complete with polypropylene guide rails. Guide rail distance 125 mm, capacity 10 or 20 trays. Guide rails have tray stops to prevent the trays sliding. The trolleys are fitted with 125 mm ball bearing wheels, two with brakes. Other tray sizes on request.

Accessory: s/s shelf on to top of the trolley or to lower guide rails

Product	Code	Dimensions mm	Trays
TRT-10	4554340	410x590x1591	10 pcs 430-530x325 mm
TRT-20	4554454	775x590x1591	20 pcs 430-530x325 mm

Accessories	Code	Dimensions mm
S/S shelf	4554158	330x560x35
Fender TRT-10*	4554165	464x642
Fender TRT-20*	4554167	826x642

\* to be ordered with trolley

Flat pack	Code	Package dimensions mm
FPTRT-10	4554432	1775x610x153
FPTRT-20	4554458	1775x610x153



Stainless steel shelf.

## TRAY RETURN TROLLEYS WITH LAMINATED COVERS



TRT-10C tray return trolley with s/s shelf on top.

**Nordien-System tray return trolleys** as single or double models. Standard tray size 430-530 x 325 mm. Frames are stainless steel complete with polypropylene guide rails. Guide rail distance 125 mm, capacity 10 or 20 trays. Guide rails have tray stops to prevent the trays sliding. The trolleys are fitted with 125 mm ball bearing wheels, two with brakes. Other tray sizes on request.

Standard colours for laminated covers are white, gray, birch and beech. Other materials on request.

Accessory: s/s shelf on to top of the trolley or to lower guide rails



TRT-20C tray return trolley with s/s shelves on top.

Product	Code	Dimensions mm	Trays
TRT-10C	4554342	410x590x1591	10 pc 430-530 x 325 mm
TRT-20C	4554344	775x590x1591	20 pc 430-530 x 325 mm

Accessories	Code	Dimensions mm
S/S shelf	4554158	330x560x35
Fender TRT-10*	4554165	464x642
Fender TRT-20*	4554167	826x642

\* to be ordered with trolley

Flat pack	Code	Package dimensions mm
FPTRT-10C	4554434	1775x610x153
FPTRT-20C	4554436	1775x610x153



## MULTIPURPOSE TROLLEY

**Nordien-System multipurpose trolley** can be used as container support when emptying kettles and peeling machines, to take the output of vegetable slicers etc. Unnecessary transfers are thus avoided. Adjustable GN runners, heights 450, 550, 650, 750 and 850 mm. Construction stainless steel throughout. The trolley is fitted with 75 mm ball bearing wheels, two with brakes. GN containers are optional.

Product	Code	Dimensions mm	
MPT-450	4554354	570x400x1040	GN1/1
MPT-2/450	4554355	590x720x1040	GN2/1



MPT-450 multipurpose trolley.



MPT-2/450 multipurpose trolley.

## TRANSPORT TROLLEY

**Nordien-System platform trolley** is sturdy stainless steel throughout. The PFT-67 trolley is fitted with 125 mm ball bearing wheels (PFT-75 with 75 mm), two with brakes. PFT-67 maximal load capacity is 60 kg and PFT-75 200 kg.

Product	Code	Dimensions mm
PFT-67	4554358	730x465x920
PFT-75	4554360	820x600x900



PFT-67 transport trolley.



PFT-75 transport trolley.

## SPICE TROLLEYS



SPT-600 spice trolley

**Nordien-System spice trolley** conveniently takes spices to the work point. The trolleys are sturdy and stainless steel throughout. Two models. Ball bearing castors, two of castors have brakes.

Product	Code	Dimensions mm	Capacity
SPT-500	4554128	400x475x920	25 pcs Tetra-Pak
SPT-600	4554130	600x550x850	28 pcs Tetra-Pak



SPT-500 spice trolley

## FLOUR TROLLEYS



IBI-81 flour trolley

Nordien-System flour trolleys are for storing flour, sugar, rice etc. Easily reached products and convenient space saving storage under table.

**Nordien-System JAV** flour trolley is tight, sturdy and of stainless steel throughout. Ball bearing castors, of which two equipped with brakes.

Product	Code	Dimensions mm
JAV-100	2026446	480x600x660



JAV-100 flour trolley

**Nordien-System IBI flour trolley** is white food grade polypropylen, lid is polycarbonate. Lid is easily opened with one hand. Flour scoop has a place under the lid. Four castors, two of them with brakes. Two sizes: 81 and 102 litres.

Product	Code	Dimensions mm
IBI-81	4133246	333x743x711
IBI-102	4133252	394x749x711



IBI-102 flour trolley

## LAUNDRY TROLLEY



LAT laundry trolley.

**Nordien-System laundry trolley** is for collecting soiled linen in restaurants, room service etc. Frames are sturdy stainless steel throughout. The stong cotton sack is suspended to frame with strings. The trolley is fitted with 125 mm ball bearing wheels, two with brakes.

Product	Code	Dimensions mm
LAT	4554362	800x480x910

Flat pack	Code	Package dimensions mm
FP LAT	4554438	1255x610x153

## BASIN TROLLEYS

**Nordien-System basin trolley** is sturdy and of stainless steel throughout. Thanks to seamless construction and rounded corners, the trolley is hygienic and simple to clean. The trolley is fitted with 125 mm ball bearing wheels, two with brakes. Basin capacities are indicated by model numbers. The basin is fitted with a closing valve.

Product	Code	Dimensions mm	Basin mm
AV-45	4554600	470x570x800	400x500x250
AV-50	4554602	615x765x800	550x700x140
AV-70	4554604	470x670x800	400x600x300
AV-75	4554606	610x610x700	550x550x250
AV-90	4554608	615x765x800	550x700x250
AV-175	4554610	610x610x720	550x550x550



AV-45 basin trolley



AV-175 basin trolley



245 cutlery soak trolley with cutlery chute

## CUTLERY SOAK TROLLEY

**Nordien-System cutlery soak trolley** is of stainless steel. A 500x500 mm dishwashing basket fits in it. The trolley is fitted with 125 mm ball bearing wheels, two with brakes. The basin is fitted with a closing valve.

Accessory: cutlery chute, which can be easily removed for cleaning.

Product	Code	Dimensions mm	Basin depth mm
245	4554620	550x550x700	250
263	4554622	cutlery chute	

# WASTE TROLLEYS



217 waste trolley.

**Nordien-System waste trolley** in heavy duty design with rilsan coated handles. Convex bottom for easier emptying and cleaning. Diameter 385 mm and volume 45 litres. Separate stainless steel chassis is fitted with 75 mm ball bearing wheels, two with brakes.

Delivery includes bin and chassis.

Product	Code	Diameter	Height	Volume
217	4551222	Ø 385	615 mm	45 litres



WAB-45 waste bin.

**Nordien-System WAB conical waste bin** in grey plastic. Diameter and volume: 458 mm/45 liters and 485 mm/65 litres. Separate stainless steel chassis is fitted with 75 mm ball bearing wheels, two with brakes.

Delivery includes bin and chassis.  
Accessory: lid

Product	Code	Diameter	Height	Volume
WAB-45	4554366	Ø 458 mm	535 mm	45 l
WAB-65	4554368	Ø 485 mm	580 mm	65 l

Accessories	Code
Lid 45 litres	4554194
Lid 65 litres	4554196



WAB-65 waste bin with a lid.



WAT-60 waste trolley.

**Nordien-System WAT waste trolley.** Plastic bin with cover. Cover opening ø 150 mm. Platform with push-handle of stainless steel. The trolley is fitted with 75 mm ball bearing wheels, two with brakes. Handle is detachable.

Accessory: 60 l extra plastic bin

Product	Code	Dimensions	Volume
WAT-60	4554370	285x555x660*	60 l
WAT-120	4554372	555x555x660*	2x60 l

\*Total height with the plastic bin is 720mm.

Accessory	Code	Dimensions	Volume
WAC-60	4554526	285x555x620	60 l extra plastic bin



WAT-120 waste trolley

## SACK TROLLEY

**Nordien-System sack trolley** is made of rilsan finished spring steel in a construction that keeps the sack stretched. Colour grey. The trolley is fitted with 75 mm ball bearing wheels, two with brakes.

Product	Code	Dimensions mm	Sack volume
SAT-60	4551250	365x340x750 mm	60 litres
SAT-125	4551248	485x450x800 mm	125 litres



SAT Sack trolley

## WASTE TROLLEYS AND CUPBOARDS



LBJV-2 waste trolley with tray shelf, two 30 litre bins

The sorting of kitchen waste has become part of modern waste management. Sorting out organic waste from other waste for composting decreases environmental load. From the range you will find a wide variety of solutions enabling you to link waste management to other kitchen activities.

**Nordien-System waste trolleys** and cupboards are manufactured of stainless steel. Detachable guide collars and open bottom makes the construction easy to clean. Guide collar diameter is 240 mm, except in model LBJVM-2 the diameter is 180 mm. Cupboard models are fitted with adjustable legs and trolley models with 125 mm ball bearing wheels, two with brakes. A drop-down tray shelf is available as an accessory. The shelf is easy to fit into the mounting holes.



LBJV-1 waste trolley with a 30 litre bin



LBJVM-2 waste trolley with tray shelf, two 10 litre bins



Open construction, in hygienic stainless steel throughout, does not collect dirt.



Detachable guide collar.

Waste cupboards	Code	Outer dim. mm	Volume
LBJK-1	4208458	400x580x850	30 l
LBJK-2	4208465	800x580x850	2 x 30 l

Waste trolleys	Code	Outer dim. mm	Volume
LBJV-1	4208472	400x580x850	30 l
LBJV-2	4208497	800x580x850	2 x 30 l
LBJVM-2	4208507	400x580x850	2 x 10 l

Accessories	Code	Outer dim. mm	Volume
Tray shelf	4150906	400x250 mm	
Tray shelf	4150977	800x250 mm	
Guide collar	4208627	diam. 240 mm	
Guide collar	4140913	diam. 180 mm	
Plastic waste bin	4150938		30 l
Plastic waste bin	4250010		10 l

# NORDIEN-SYSTEM RACKS FOR 500 x 500 mm BASKETS

**Nordien-System service racks** are designed to better utilise limited storage space and to reduce the distance for dishwashing, serving and kitchen staff. The racks help to reduce breakages and the staff have more time for efficient work and improved service to guests. All racks are available for 460x460 mm baskets.



901 double



902 single



903 double



904 single



905 double



906 single



907 double



908 single

## RESTAURANT RACKS

**Restaurant racks** have angled shelves for easier access. Available as single and double models.

For glasses				Capacity
500 baskets	Code	Dimensions mm	Shelves	glasses approx.
901 double	4551308	1100x520x1910	6	430
902 single	4551310	590x520x1910	6	210

For glasses/crockery				Glasses/
500 baskets	Code	Dimensions mm	Shelves	plates approx.
903 double	4551312	1100x520x1910	5	300/240
904 single	4551314	590x520x1910	5	150/120

## SERVING RACKS

**Serving racks** are adapted so that serving staff can easily take those items which are needed for laying tables. Available as single and double models.

For glasses/crockery/cutlery				Glasses/plates/
500 baskets	Code	Dimensions mm	Shelves	cutlery approx.
905 double	4551316	1100x520x1910	5	210/350/450
906 single	4551318	590x520x1910	5	100/170/220

For glasses/crockery/cutlery				Glasses/plates/
500 baskets	Code	Dimensions mm	Shelves	cutlery approx.
907 double	4551320	1100x520x1910	6	280/240/450
908 single	4551322	590x520x1910	6	140/120/450

# NORDIEN-SYSTEM RACKS FOR 500 x 500 mm BASKETS

The service racks are made in stainless steel square tubing, 20x20 mm. Stainless steel distance tubing and shelves. Grid shelves in polypropylene. Manufactured with adjustable feet. The service racks are very stable. The racks are easily assembled with supplied tools.



909 double



910 single



911 double



912 single



913 double



914 single



915 double



916 single

## STORAGE RACKS

**Storage racks** have large capacity for glasses or cups and crockery or cutlery. Available as single and double models.

For glasses/crockery		Dimensions mm	Shelves	Glasses appr.
500 baskets	Code			
909 double	4551324	1100x520x1910	7	500
910 single	4551326	590x520x1910	7	250

For glasses/crockery/cutlery		Dimensions mm	Shelves	Glasses/plates appr.
500 baskets	Code			
911 double	4551328	1100x520x1910	7	430/240
912 single	4551330	590x520x1910	7	210/120

## SERVING RACKS

**Service racks** with a flat shelf are very suitable for preparation of trays etc. Available as single and double models.

For glasses/crockery/cutlery		Dimensions mm	Shelves	Glasses/plates/ cutlery appr.
500 baskets	Code			
913 double	4551332	1100x520x1910	8	210/100/450
914 single	4551334	590x520x1910	8	100/50/220

For glasses/crockery/cutlery		Dimensions mm	Shelves	Glasses/plates/ cutlery appr.
500 baskets	Code			
915 double	4551336	1100x520x1910	7	70/480/900
916 single	4551338	590x520x1910	7	30/240/450

# CUTLERY SORTING RACK

**Nordien-System cutlery sorting rack** is specially designed for sorting and storage of cutlery. The work surface has an upstand on three sides which prevents the cutlery from falling onto the floor.

The rack is delivered flat packed and is easily assembled with supplied tools.

Cutlery sorting and storage rack	Code	Dimensions mm	Shelves
917	4551340	1100x520x1910	7
918	4551342	590x520x1910	7



Cutlery sorting rack 917.



Basket storage rack 932.



Basket storage rack 973.

# BASKET RACK

**Nordien-System storage racks** for 12 baskets. Stainless steel frame, guide rails polypropylene with basket stops. Separate models for 500 mm and 460 mm baskets. The rack is delivered flat packed and is easily assembled.

Storage racks for baskets	Code	Dimensions mm	Capacity baskets
<b>500 baskets</b>			
932	4551058	590x520x1910	12
<b>460 baskets</b>			
973	4551092	560x490x1910	12



# CLIPS FOR RACKS

**Nordien-System clips for racks** for connecting racks to each other and making a more stable unit. Stainless steel. With wallclip the racks can be fastened to a wall. Stainless steel.

Clips for racks	Code
wallclip for racks	4551392
clip for racks	4551394



## STORAGE RACK



Storage rack 919.

Storage rack 920.

**Nordien-System storage racks** are ideal for storing crocery in cassettes. Frames are in stainless steel square tubing, 20x20 mm. Stainless steel shelves support heavy loads. Distance between shelves 340 mm. 330 mm or 520 mm deep shelves. Adjustable feet.

The rack is delivered flat packed and it is easily assembled with supplied tools.

### Storage rack

depth 330 mm	Code	Dimensions mm	Shelves	Plates approx.
919	4551344	1100x330x1910	5	600
920	4551346	590x330x1910	5	300
depth 520 mm				
921	4551348	1100x520x1910	5	1200
922	4551350	590x520x1910	5	600

## POT AND PAN RACK

**Nordien-System racks** for storing pots, pans and containers etc. Frames stainless steel square tubing 20x20 mm, grid shelves stainless steel wire. Distance between shelves 513 mm. Adjustable feet.

The rack is delivered flat packed and is easily assembled with supplied tools.

### Pot and pan rack

depth 52 cm	Code	Dimensions mm	Shelves
357	4551300	590x520x1910	4
358	4551302	1100x520x1910	4



Pot and pan rack 358.

Pot and pan rack 357.



Crate rack 360.

Crate rack 359.

## CRATE RACK

**Nordien-System crate rack** is designed for collecting empty bottles into crates and for storage of beverages. The crate shelf speeds up the handling of bottles. The rack frames are of stainless steel square tubing, 20 x 20 mm. Adjustable feet.

Crate rack		Code	Dimensions mm
360	For eighth crates	4551006	960x320x1540
359	For four crates	4551004	510x320x1540

The bottle crate shelf keeps crates firmly in place. Removal and return is fast and effortless.



At lunch or dinner the serving staff are very busy selling and serving food and drinks. This means that depositing of the dirty dishes must be easy and quick. To achieve this, Nordien-System has developed the accumulating principle for hotels and restaurants which works as follows:

**The serving staff's work:**

1. Place the cutlery in the cutlery soak trolley.
2. Scrape the left overs into the waste bin using the plate scraper.
3. Put the plates, saucers and bowls on the lower level of the carousel.
4. Glasses and cups on the upper level.

**The dishwashing staff's work:**

5. Sort the glasses and cups into the correct baskets.  
Put the full baskets in the guide rail sections under the table.  
Empty basket is put on the shelf.  
The plates are sorted according to size and are placed in piles on the sorting table.
6. If required, serving dishes can be put into the basin for soaking.
7. When the busiest period is over, the actual washing begins.  
The glass baskets are ready to be placed on the basin line for sliding into the dishwasher. Load plate baskets. Finally cutlery will be washed two times first flat and then standing UNSORTED.
8. 180° turn track and roller table return baskets to the dishwashing staff for removal.
9. The baskets are put into basket trolleys and the plates are put into cassettes on a plate cassette trolley for transport to the storage area.
10. In the storage area everything is stored in the correct place so that all staff know where to find specific items. Optimal storage racks give easy access to all goods.

## DELIVERY CAROUSEL

**Nordien-System delivery carousel:** One of Nordien-System's innovations is the delivery carousel. Since the carousel rotates all the time, the serving staff can quickly find space to dump the dirties. At the same time the steward can remain standing in the same place and sort glasses and cups into baskets and plates into piles. A carousel with two levels, diameters 1800+1500 mm is equivalent to a table 5300 mm long and 800 mm deep!



Carousel 810-1H with tray support and sink on right.

The carousel has two levels. Construction is of stainless steel. Motor driven, speed 1.2 revolutions per minute.

Tray support on one side, can be delivered with or without sink. The length is equal to the diameter of the carousel. Depth 450 mm. The tray support for corner includes 45° corner element. Adjustable feet.

Carousel	Code	Diameter mm	Height mm	El.connection
810-2 with tray support	4552358	Ø 1800+1500	1250	230V 1~18W
810-2H with tray support+sink on right	4552360	Ø 1800+1500	1250	230V 1~18W
810-2V with tray support+sink on left	4552362	Ø 1800+1500	1250	230V 1~18W
811-2 with corner tray support	4552372	Ø 1800+1500	1250	230V 1~18W
810-1 with tray support	4552352	Ø 1500+1200	1250	230V 1~18W
810-1H with tray support+sink on right	4552354	Ø 1500+1200	1250	230V 1~18W
810-1V with tray support+sink on left	4552356	Ø 1500+1200	1250	230V 1~18W
811-1 with corner tray support	4552370	Ø 1500+1200	1250	230V 1~18W
810-3 with tray support	4552364	Ø 1200+1000	1250	230V 1~18W
810-3H with tray support+sink on right	4552366	Ø 1200+1000	1250	230V 1~18W
810-3V with tray support+sink on left	4552368	Ø 1200+1000	1250	230V 1~18W
811-3 with corner tray support	4552374	Ø 1200+1000	1250	230V 1~18W

## SCRAPER

To scrape left overs from plates to the waste bin below without using hands or cutlery. The scraper can be fitted to most type of tables.



Scraper unit 421.

Scraper unit	Code
421	4551910

Scraper without holder	Code
421A exchange blade	4552136



## DELIVERY/SORTING TABLE



Delivery table includes guide rail sections either for 500x500 mm or 460x460 mm baskets are available. Delivery unit includes sorting shelf and empty basket rack. Mobile waste bin, scraper, tray support and cutlery soak trolley are accessories.

**A free standing Nordien-System delivery/ sorting table.** Serving staff can deposit dirty dishes while the dishwashing staff are sorting them on the other side. Under the table there are guide rail sections for 500 x 500 mm or 460 x 460 mm baskets.

The table can be supplied with a sorting shelf and an empty basket rack. On sorting shelf baskets can be angled towards either the serving or dishwashing staff. A basket rack is for empty baskets standing on side.

The table and shelves are of stainless steel. Outlet connection on table top. Adjustable feet.

Accessory: tray support, 300 mm deep

### Delivery unit consists of guide rail sections, sorting shelf and empty basket rack.

Delivery unit, 500 baskets	Code	Dimensions mm
640-2-50-642-644	4552264	1176x1000x2355 with shelves
640-3-50-642-644	4552266	1719x1000x2355 with shelves
640-4-50-642-644	4552268	2262x1000x2355 with shelves
640-5-50-642-644	4552270	2805x1000x2355 with shelves
640-6-50-642-644	4552272	3356x1000x2355 with shelves

### Delivery table includes guide rail sections for 500 baskets.

Delivery table, 500 baskets	Code	Dimensions mm
640-2-50	4552246	1176x1000x875±25
640-3-50	4552250	1719x1000x875±25
640-4-50	4552254	2262x1000x875±25
640-5-50	4552258	2805x1000x875±25
640-6-50	4552262	3356x1000x875±25

### Delivery unit consists of guide rail sections, sorting shelf and empty basket rack.

Delivery unit, 460 baskets	Code	Dimensions mm
640-2-46-642-644	4552274	1176x1000x2355 with shelves
640-3-46-642-644	4552276	1719x1000x2355 with shelves
640-4-46-642-644	4552278	2262x1000x2355 with shelves
640-5-46-642-644	4552280	2805x1000x2355 with shelves
640-6-46-642-644	4552282	3356x1000x2355 with shelves

### Delivery table includes guide rail sections for 460 baskets.

Delivery table, 460 baskets	Code	Dimensions mm
640-2-46	4552244	1176x1000x875±25
640-3-46	4552248	1719x1000x875±25
640-4-46	4552252	2262x1000x875±25
640-5-46	4552256	2805x1000x875±25
640-6-46	4552260	3356x1000x875±25

# SORTING TABLE

**Nordien-System sorting tables** are available in two designs, either for placing against the wall or free standing. The wall model has an upstand at the back while the free standing model has a low edge on all four sides. The tables are normally supplied with one or two sorting shelves which are either attached to the table top or wall mounted with brackets. If only one sorting shelf is used, a basket rack can be mounted above.

The table top, as well as the sorting shelves, are provided with drainage outlet. Under the table, guide rail sections for 500x500 mm or 460x460 mm baskets are standard.

Table tops and sorting shelves in stainless steel sheet. Adjustable feet.



Sorting table includes guide rail sections for either 500x500 mm or 460x460 mm baskets are available. Mobile waste bin, plate cassettes and scraper are accessories.

## Sorting table for 500 baskets

Placing against the wall	Code	Dimensions mm
600V-2-50	4552186	1176x800x875±25
600V-3-50	4552190	1719x800x875±25
600V-4-50	4552194	2262x800x875±25
600V-5-50	4552198	2805x800x875±25
600V-6-50	4552202	3356x800x875±25

## Free standing

620F-2-50	4552206	1176x800x875±25
620F-3-50	4552210	1719x800x875±25
620F-4-50	4552214	2262x800x875±25
620F-5-50	4552218	2805x800x875±25
620F-6-50	4552222	3356x800x875±25

## Sorting table for 460 baskets

Placing against the wall	Code	Dimensions mm
600V-2-46	4552184	1176x800x875±25
600V-3-46	4552188	1719x800x875±25
600V-4-46	4552192	2262x800x875±25
600V-5-46	4552196	2805x800x875±25
600V-6-46	4552200	3356x800x875±25

## Free standing

620F-2-46	4552204	1176x800x875±25
620F-3-46	4552208	1719x800x875±25
620F-4-46	4552212	2262x800x875±25
620F-5-46	4552216	2805x800x875±25
620F-6-46	4552220	3356x800x875±25

Sorting shelf wall mounted	Code	Dimensions mm
650-2	4552284	1076x550
650-3	4552286	1619x550
650-4	4552288	2162x550
650-5	4552290	2705x550
650-6	4552292	3248x550

Brackets	Code	
654	4552118	for one shelf
653	4552116	for two shelves

Suitable for 500 and 460 baskets

## BASKET RACK WALL MOUNTED

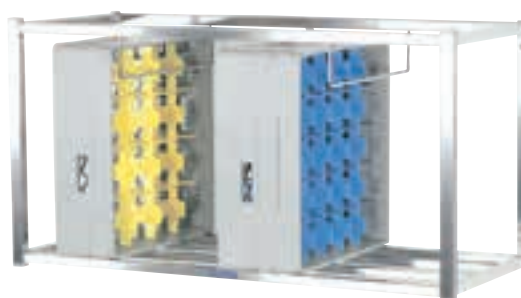

For 460 and 500 baskets	Code	Dimensions mm
501-2	4552158	1136 x 560 x 480 mm
501-3	4552160	1679 x 560 x 480 mm
501-4	4552162	2222 x 560 x 480 mm
501-5	4552164	2765 x 560 x 480 mm
501-6	4552166	3308 x 560 x 480 mm

## PRE-WASH TABLES FOR HOOD TYPE MACHINES



The basin line 700-6-3 with 600 mm basin is supplied with a splash guard and a connection plate to machine; the pre-rinse shower, the unloading table and the grid shelf are accessories.

**Nordien-System basin** is of sturdy stainless steel throughout with guide rails for baskets. There is a large strainer at the bottom of the basin which can be lifted upwards and an outlet ball valve connection. The basin depth is 300 mm. Adjustable feet. Connection plates available in lengths 300 mm and for angled installation 500 mm. The basins are supplied with splash guards.

Basin	Code	Outer dimensions mm	Installation length
300 mm connection plate:			
700-11-3	4552316	1100x590x880±25	1400 mm
700-6-3	4552320	600x590x880±25	900 mm
700D-6-3, 2 basins	4552332	1200x590x880±25	1500 mm

500 mm connection plate for angled installation:			
700-11-5	4552319	1100x590x880±25	1600 mm
700-6-5	4552317	600x590x880±25	1100 mm
700D-6-5, 2 basins	4552321	1200x590x880±25	1700 mm

Accessories:	Code	Dimensions mm	For basins
Grid shelf	4552324	600x590	700-6-3, 700-6-5
Grid shelf	4552326	1100x590	700-11-3, 700-11-5
Grid shelf	4552328	1200x590	700D-6-3, 700D-6-5
Unloading table	4552325	500x590	

## DRYING LINE

**Nordien-System drying line** for hood type dishwashing machines. The construction is of sturdy stainless steel throughout. Drip tray with outlet drainage. Guide rail section for storage of empty 500 x 500 mm baskets. Adjustable feet.

Drying line	Code	Dimensions mm	Guide rail sections
750-0	4552345	700x580x875±25	1
750-1	4552346	1100x580x875±25	1
750-2	4552348	1600x580x875±25	2
750-3	4552350	2100x580x875±25	3



Double basin line 700D-6 with two 600 mm basins.



Drying line 750-1.

## PRE-WASH SHOWERS



6546 pre-wash shower with a thermostatic mixer and table mounting.

**Europe line of pre-rinse showers** 4013-, 3050, 4023 and 3034 are traditional pre-wash showers with a handled jet pistol. Pre-wash showers are supported at the top with a wall fitting. The shower is started by pushing down the handle. A spring returns the handle to its initial position. Metos 4013 (wall mounted) and Metos 3050 (table mounted) are pre-rinse showers with a down spout and a mixer with two grips. WM 4023 (wall mounted) and TM 3034 (table mounted) are pre-rinse showers with a downspout and a mixer with a long single grip lever.

Europe line	Code	Dimensions mm
Metos WM 4013 (wall, two grips)	4218439	h 1050
Metos TM 3050 (table, two grips)	4218441	h 1500
Metos WM 4023 (wall, single grip)	4218443	h 1050
Metos TM 3034 (table, single grip)	4218445	h 1300

**Top line pre-wash showers** 6546 (table mounted) and 6548 (wall mounted) are Top line pre-wash showers with a thermostatic mixer and a downspout. Top line showers start automatically when the jet pistol is pulled down. The showers are supported at the top by a wall fitting. The showers come with an 2,5 m extension hose, which can be attached to the shower using a bayonet catch (included). By using the extension the showers can be used for cleaning the washing area.

Top Line	Code	Dimensions mm
Metos 6546 table	4218431	h 1250
Metos 6548 wall	4218495	h 950



WM 4013



TM 3034

## WASHING PISTOL

**The washing pistol with hose reel** is wall mounted and can be used for pre-rinsing, cleaning the dishwashing machine and other surroundings. The spray cone can be adjusted from the ergonomic grip. The length of the hose is 8 metres. Thermostatic mixer is an option.

Washing pistol	Code
Washing pistol	4197996
Washing pistol with hose reel	4551900
Thermostatic mixer	4552034
Mixer	4552036



The washing pistol with hose reel for handy cleaning.

# POWERED TURN TRACK



Powered turn track 445, 180°.



Powered turn track 446, 90°.

**Nordien-System powered turn track** for transporting baskets by friction driven conical rollers is connected to exit end of the rack conveyor machine. Operates with all dishwashing baskets and rack conveyor machines. The unique construction guarantees a smooth movement of baskets. All stainless steel construction. Outlet connection.

The range includes both 90 degree and 180 degree curves.

Powered turn track	Code	Dimensions mm
445 180°	4552102	780x1400x875±25
446 90°	4552104	780x780x875±25

Accessories	Code	Dimensions mm
Roller connection 454	4552106	length 300 mm
Connection plate steel 456	4552108	length 300 mm



Roller connection 454.



Connection plate 456.



Drain in the bottom of the basin.



# ROLLER TABLE



The roller sections are easy to lift for washing.



Static roller table 465-3 with two guide rail sections.



Unloading table 430.

**Nordien-System roller table** is attached to the exit of the machine or powered turn track. The construction is of stainless steel. Resistant full length plastic rollers with ball bearings. The roller sections are easy to lift for washing. Outlet drainage either into turn track or from the bottom of the unit. Shelf and rails for storing empty 500 x 500 baskets. Adjustable height.

Pivoted table has four 125 mm ball bearing wheels, two with brakes. If the roller table is connected to a 180 degree curve a pivoted model is advisable.

Pivoted roller table for 180 degree curve			Guide rail sections
	Code	Dimensions mm	
460-2	4552138	1060x630x875±25	1
460-3	4552140	1585x630x875±25	2
460-4	4552142	2110x630x875±25	3
460-5	4552144	2635x630x875±25	4
460-6	4552146	3160x630x875±25	5

Static roller table for 90 degree curve			Guide rail sections
	Code	Dimensions mm	
465-2	4552148	1060x630x875±25	1
465-3	4552150	1585x630x875±25	2
465-4	4552152	2110x630x875±25	3
465-5	4552154	2635x630x875±25	4
465-6	4552156	3160x630x875±25	5

Static roller table for connection to rack conveyor machine			Guide rail sections
	Code	Dimensions mm	
465-2D-WD	4552145	1060x630x875±25	1
465-3D-WD	4552149	1585x630x875±25	2
465-4D-WD	4552151	2110x630x875±25	3
465-5D-WD	4552161	2635x630x875±25	4
465-6D-WD	4552163	3160x630x875±25	5

Accessories	Code	Dimensions mm
Unloading table 430	4552100	width 500 mm depth 300 mm

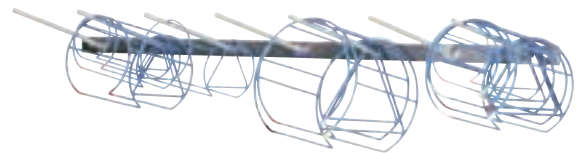

Wall mounted holder	Code	Dimensions mm
502-2	4552168	1120
502-3	4552170	1660
502-4	4552172	2200

Drying line mounted holder	Code	Dimensions mm
502T-2	4552174	1120
502T-3	4552176	1660
502T-4	4552178	2200
502T-5	4552180	2535
502T-6	4552182	3060

# Installation drawings

## KEY TO NUMERICAL SYMBOLS

1. Electric connection
2. Cold water connection
3. Hot water connection
4. Drain
5. Gas connection
6. Steam connection
7. Condensing water connection
8. Steam exhaust
9. Recommended floor drain/pit (not Metos delivery)
11. Alternative el. connection
12. Alternative cold water connection
13. Alternative hot water connection
14. Alternative drain
15. Alternative gas connection
16. Alternative steam connection
17. Alternative condensing water connection
18. Alternative steam exhaust
19. Alternative floor drain / pit
21. Non-return valve
22. Vacuum valve
23. Safety valve
24. Main switch
25. Closing valve
26. Protective tube for electric cables
27. Strainer
28. 2 m electric cable needed
29. Heated equipment
30. Maintenance space
33. Water filter
41. Heat resistant drain tube
42. Inclination 5 %
43. Compressed air
44. Treated water (optional)
45. Data cable (eg HACCP), min. 20 mm cover tube must be reserved
46. Control cables for cooling and heating control in the building  
2 pc of min. 20 mm cover tubes must be reserved
47. Remote cooling unit connection, supply
48. Remote cooling unit connection, exit
49. BUS cable
50. Ice water in
51. Ice water out
52. Detergent connection
53. Ice bank control cable

Principal dimensions: AxBxC = width x depth x height

# METOS PROVENO

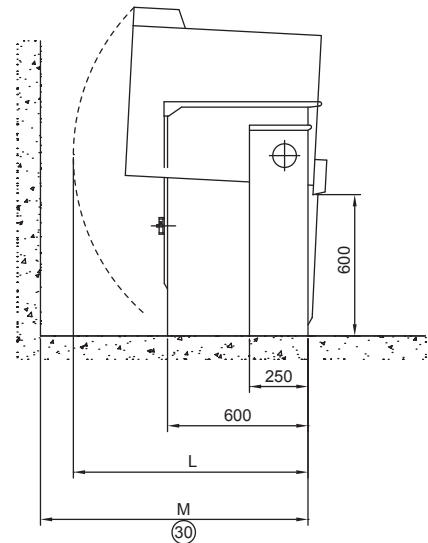
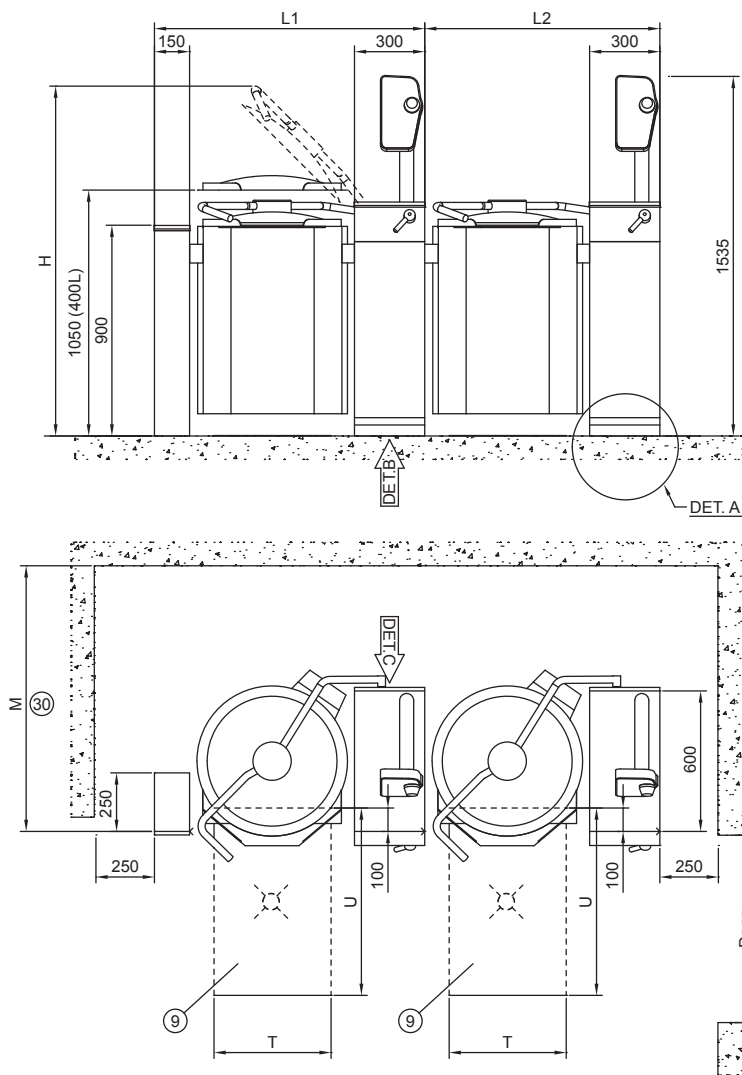

## Connection options

DET. C  
Connection from back

DET. B  
Connection area from ground

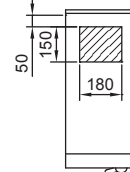
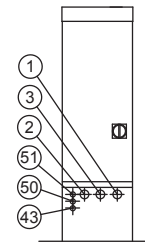

- ② R 1/2"
- ③ R 1/2"
- ⑤① R 3/4" (option)
- ⑤① R 3/4" (option)
- ④③ R 1/2" (option)

Proveno 2G	L1	L2	H	L	M	U	T	Door
40E	1047	897	1740	860	1080	800	400	800
60E	1047	897	1740	945	1080	800	400	800
80E	1154	1004	1745	1000	1230	800	500	800
100E	1154	1004	1745	1000	1230	800	500	800
150E	1360	1210	1945	1070	1175	800	600	1000
200E	1360	1210	1945	1070	1175	800	600	1000
300E	1560	1410	2110	1270	1300	1200	600	1200
400E	1560	1410	2080	1280	1315	1200	600	1200

## DET. A

Installation on subsurface frames casted into the floor.

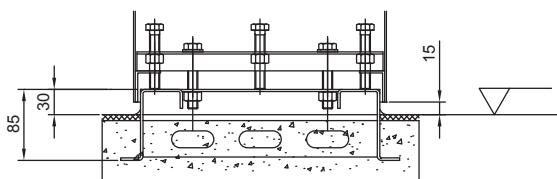

Installation on surface installation frames.

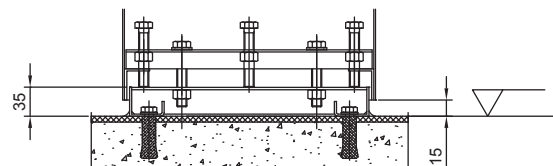

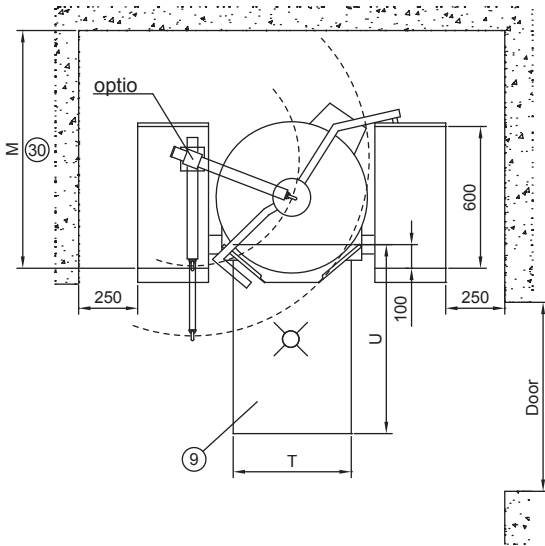
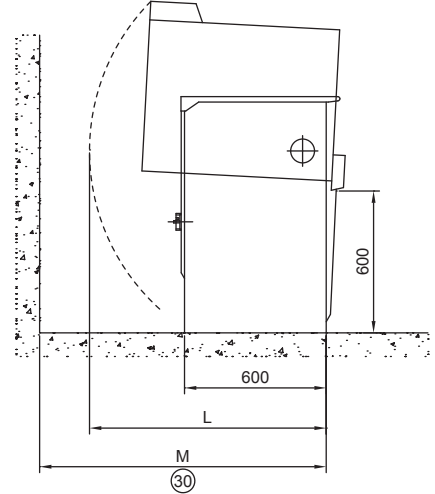
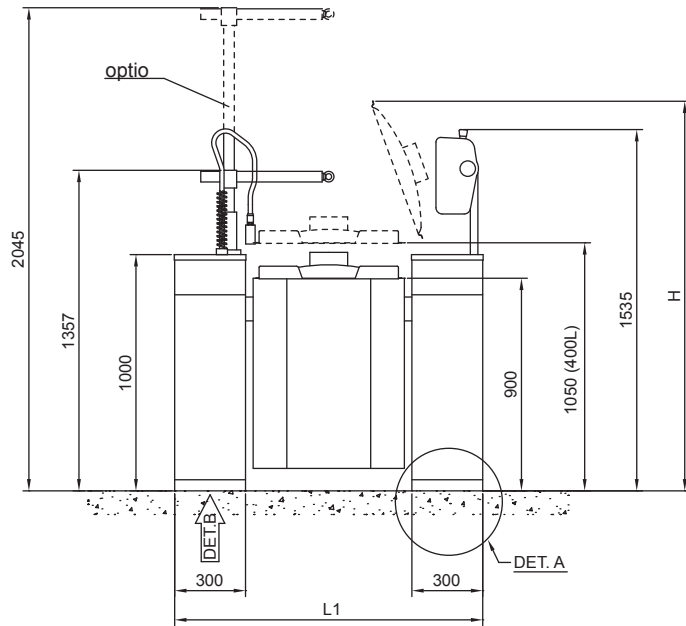

### Connection options

Connection from back

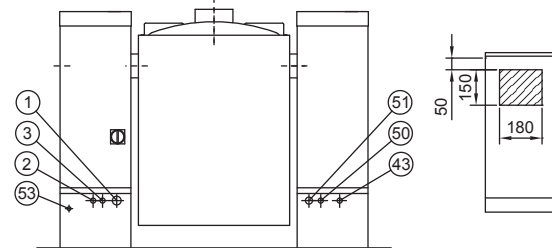

DET. B  
Connection area from ground, both pillars

- ② R 1/2"
- ③ R 1/2"
- ⑤① R 1/2"
- ⑤① R 3/4"
- ④③ R 1/2"

Proveno 2G Climatic	L1	H	L	M	U	T	Door
100E	1304	1745	1000	1230	800	500	800
150E	1510	1945	1070	1175	800	600	1000
200E	1510	1945	1070	1175	800	600	1000
300E	1710	2110	1270	1300	1200	600	1200

### DET. A

Installation on subsurface frames casted into the floor.

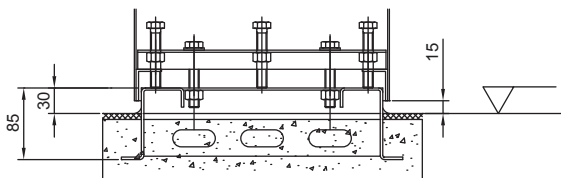

Installation on surface installation frames.

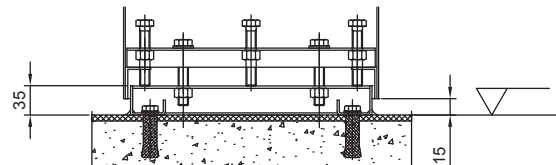

# KETTLE DRAW OFF VALVE CONNECTION

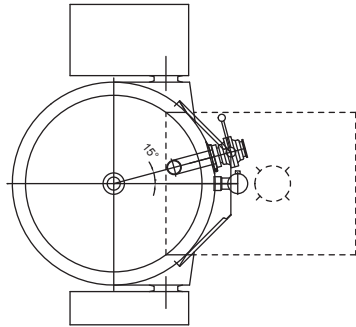
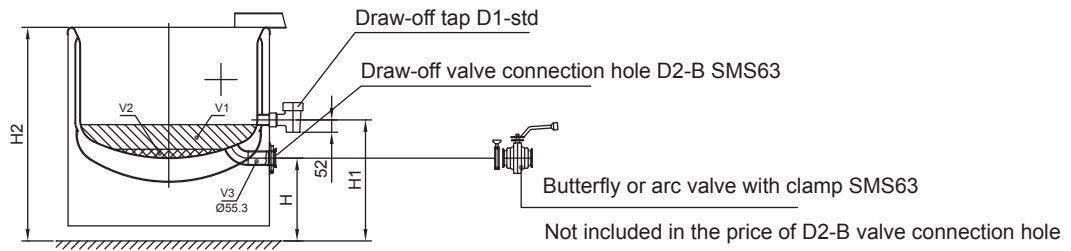

KETTLE	V1 litr.	V2 litr.	V3 litr.	H mm	H1 mm	H2 mm
40					700	900
60					575	900
80	13	2,5	0,3	485	590	900
100	13	2,5	0,3	405	510	900
150	38	3	0,5	465	625	900
200	38	3	0,5	350	510	900
300	70	4	0,7	360	550	900
400	70	4	0,7	370	560	1050

	L1	L2	H	L	M	U	T
40E	1047	897	1740	860	1080	800	400
60E	1047	897	1740	945	1080	800	400
80E	1154	1004	1745	1000	1230	800	500
100E	1154	1004	1745	1000	1230	800	500
150E	1360	1210	1945	1070	1175	800	600
200E	1360	1210	1945	1070	1175	800	600
300E	1560	1410	2110	1270	1300	800	600
400E	1560	1410	2080	1280	1315	1200	600

# METOS CULINO & VIKING 40-100E

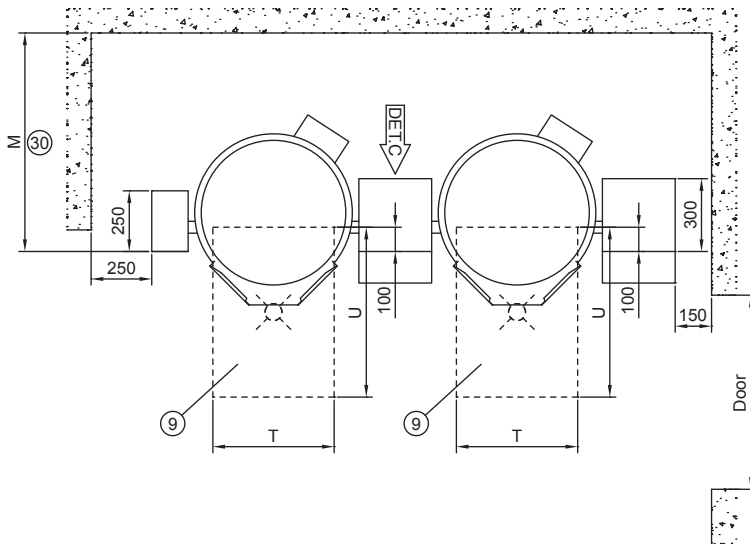
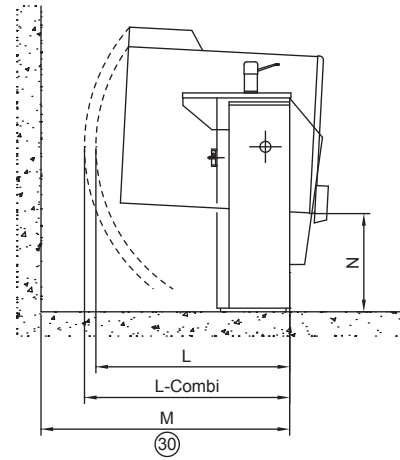
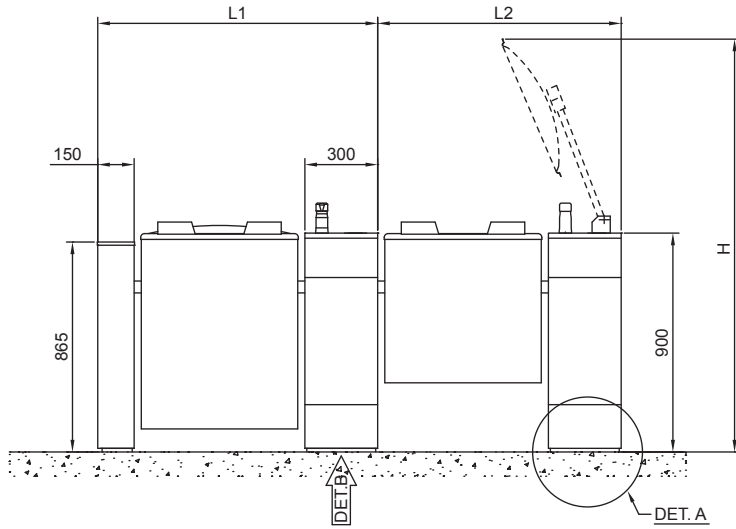

## Connection options

DET. C Connection from back  
DET. B Connection area from ground

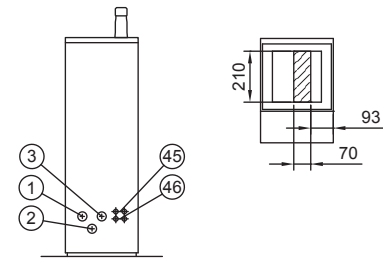

- ② R 1/2"
- ③ R 3/8"
- ④⑤ option
- ④⑥ option

Culino & Viking	L1	L2	H	L -Combi	L	M	N	U	T	Door
40E	1047	897	1710	730	630	900	455	800	400	730
60E	1047	897	1710	820	630	1040	455	800	400	730
80E	1154	1004	1800	850	710	1080	405	800	500	785
100E	1154	1004	1800	850	710	1080	405	800	500	785

## DET. A

Installation on subsurface frames casted into the floor.

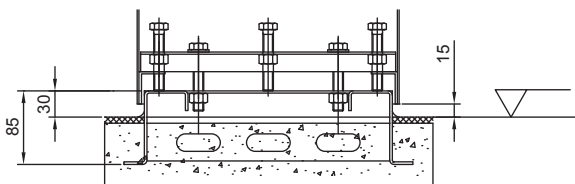

Installation on surface installation frames.

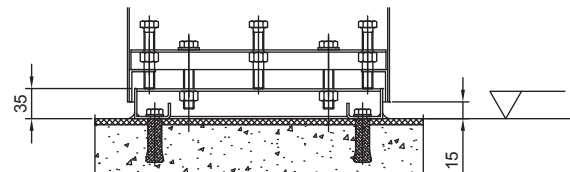

# METOS CULINO & VIKING 150-400E

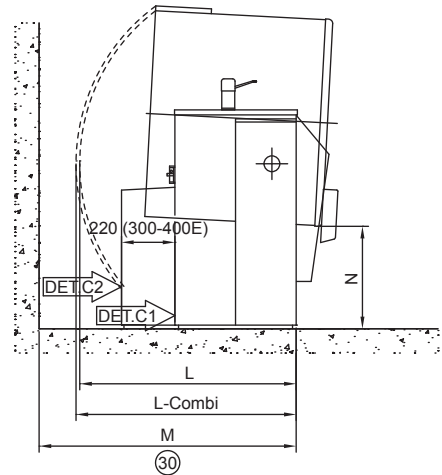
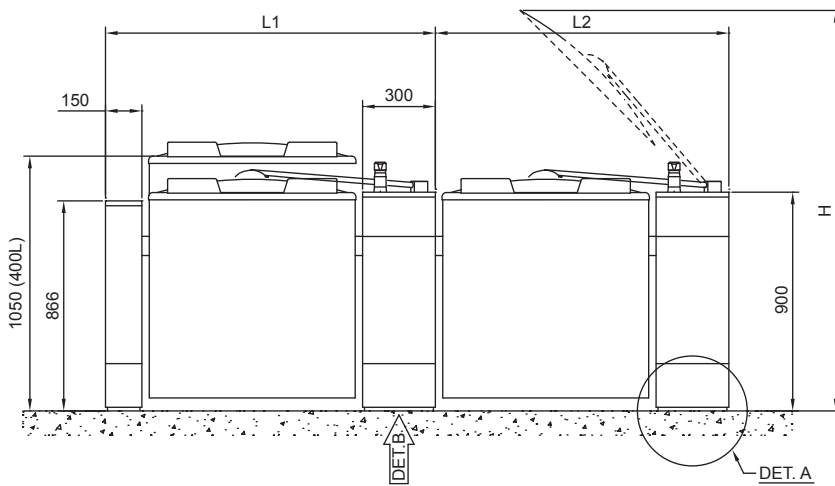

## Connection options

DET.C1  
Connection from back  
150-200E

DET.B  
Connection area from ground  
150-200E

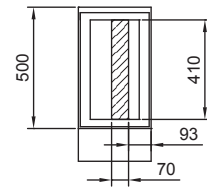
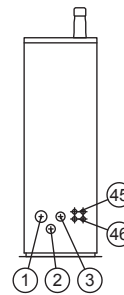

DET.C2  
Connection from back  
300-400E

DET.B  
Connection from ground  
300-400E  
a) outside pillar  
b) inside pillar

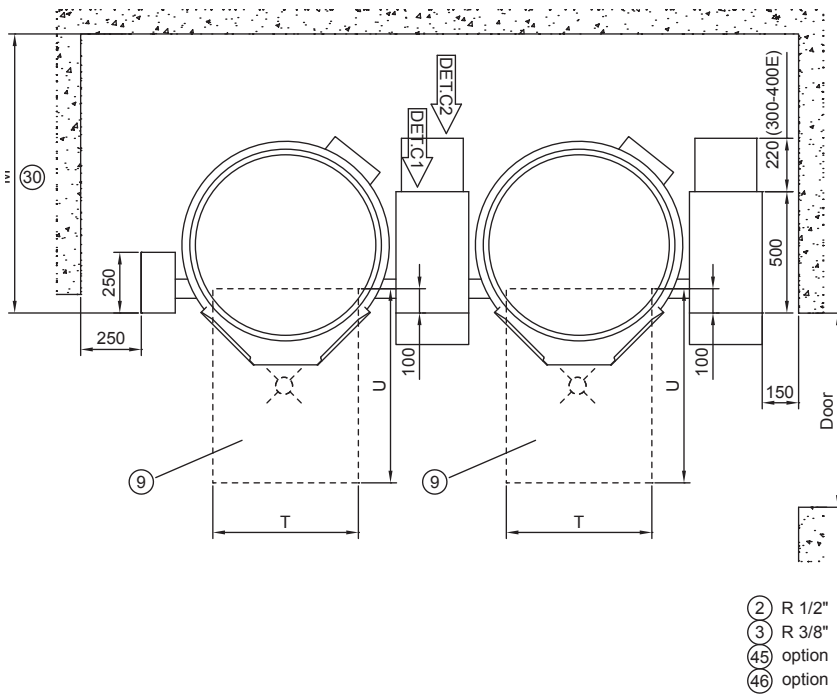
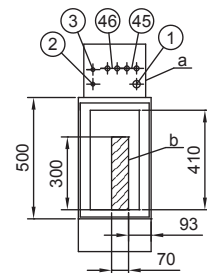
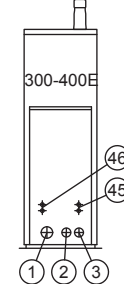

Culino & Viking	L1	L2	H	L - Combi	L	M	N	U	T	Door
150E	1360	1210	1980	910	895	1010	420	800	600	945
200E	1360	1210	1980	980	895	1130	420	800	600	945
300E	1560	1410	2100	1135	1135	1190	450	1200	600	1165
400E	1560	1410	2235	1135	1135	1190	440	1200	600	1165

## DET. A

Installation on subsurface frames casted into the floor.

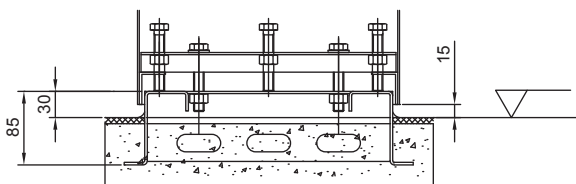

Installation on surface installation frames.

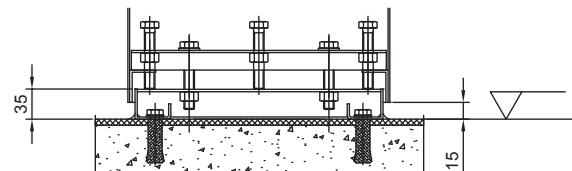

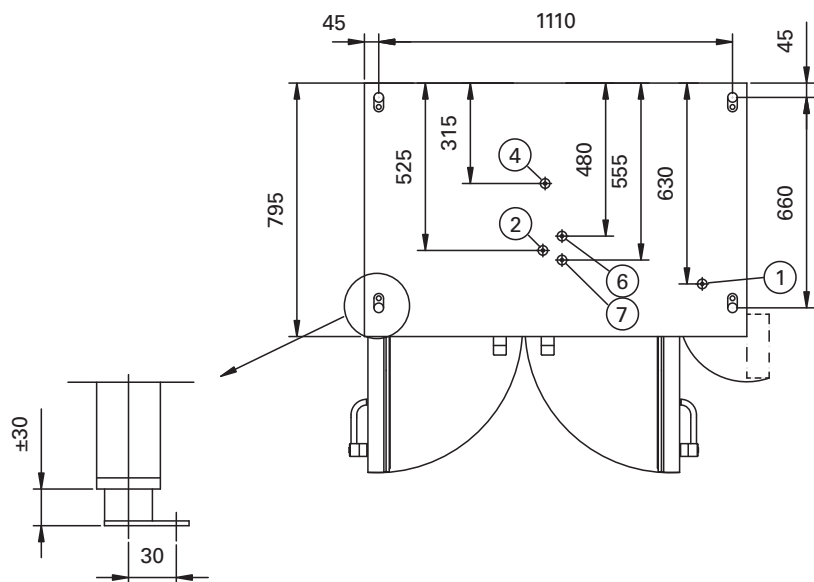
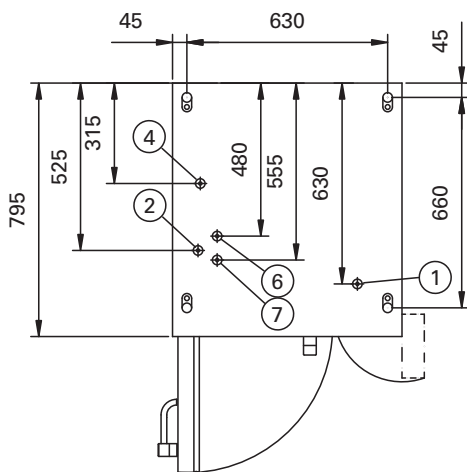
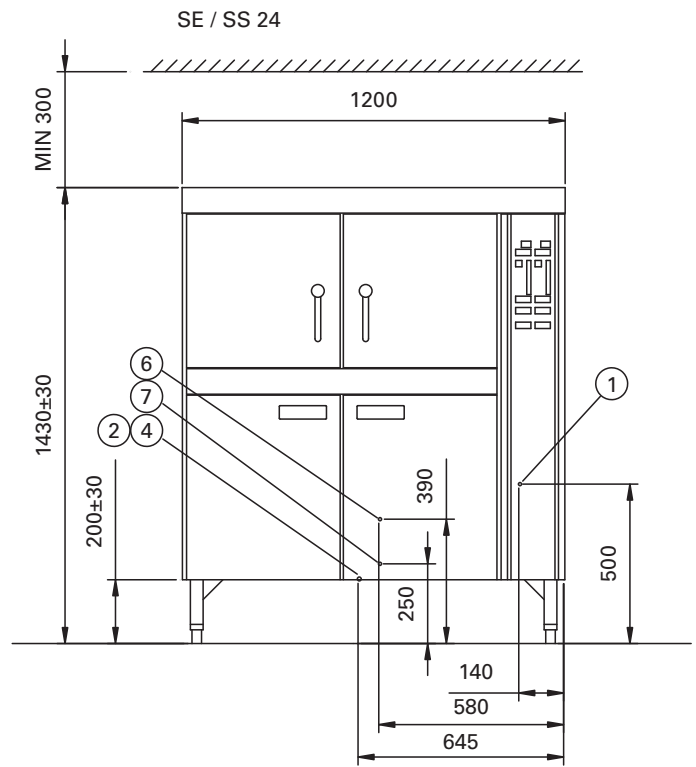
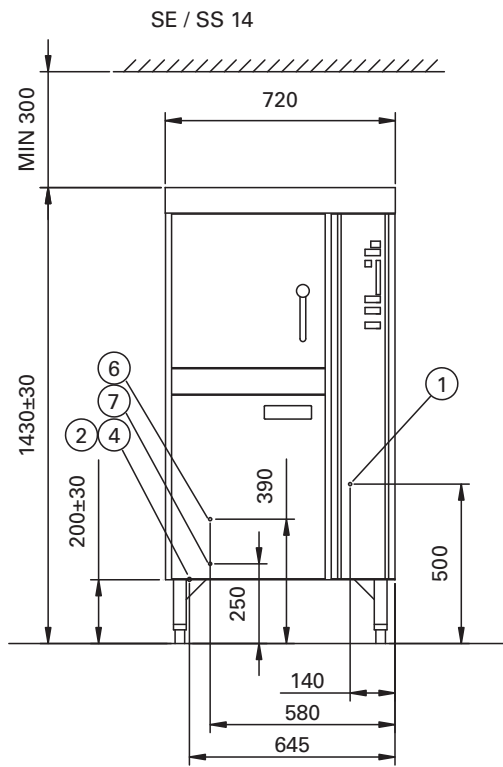

- ② 1/2"
- ④ 32 mm
- ⑥ R 3/4"
- ⑦ R 1/2"



# METOS CHEF 200 / 220 / 240

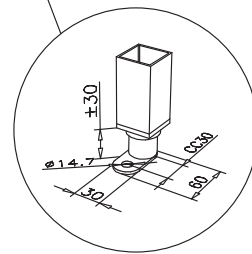
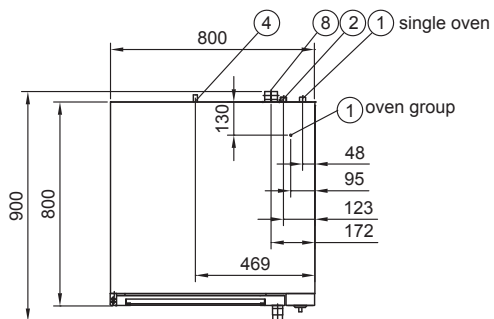
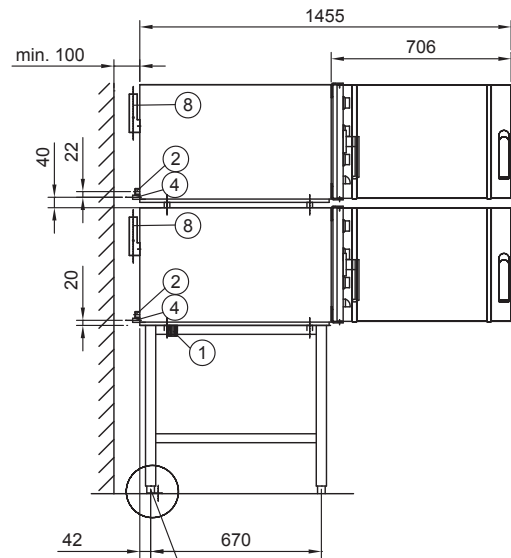
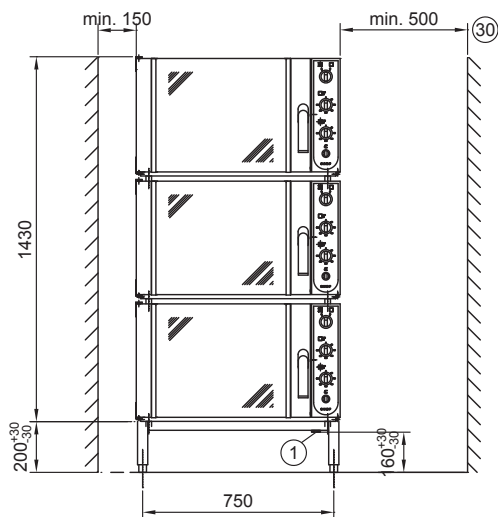
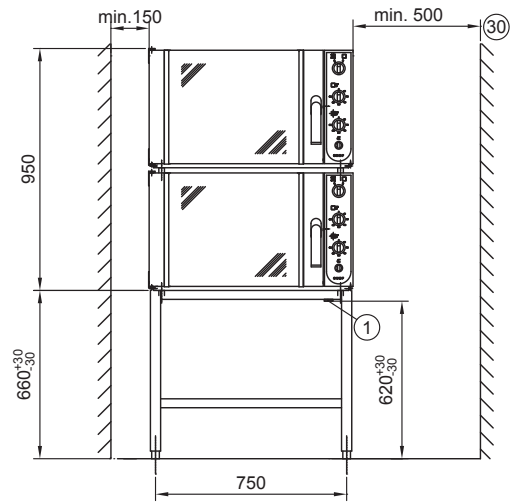
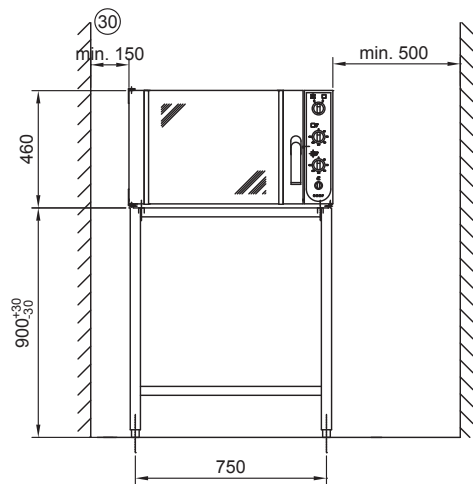

- ② R 3/4", CHEF 200 / 240
- ④ R 3/8", CHEF 240
- ⑧ duct 30x50 mm

# METOS CHEF 40 / 50

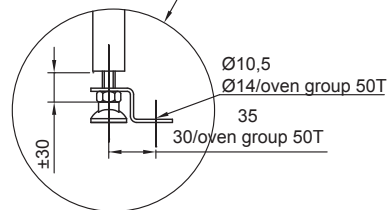
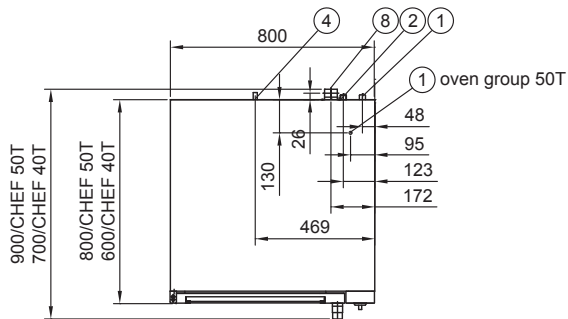
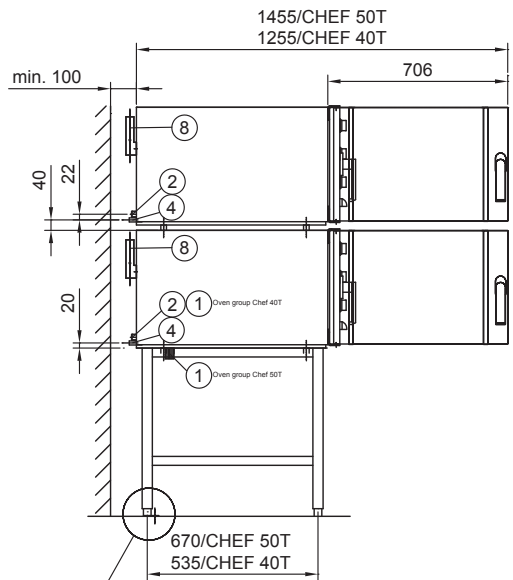
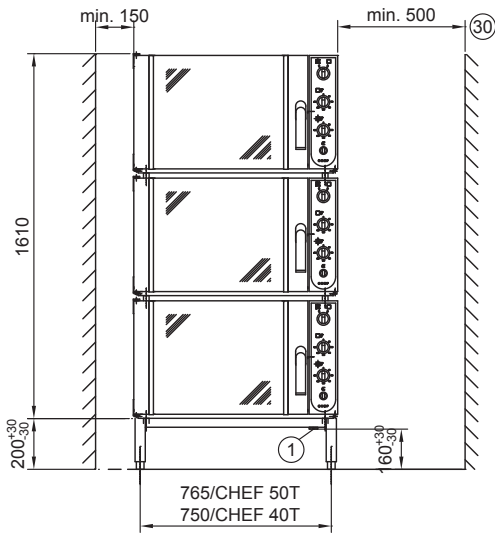
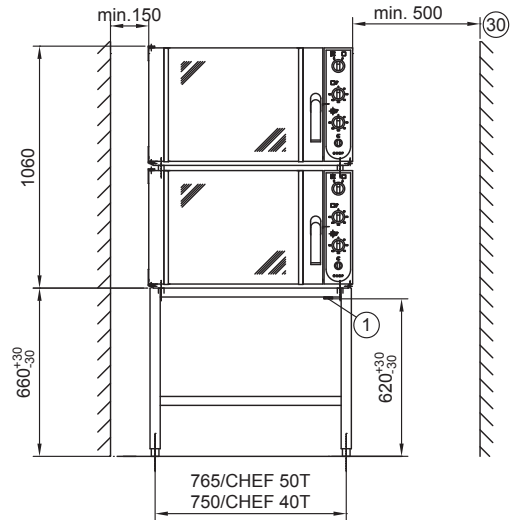
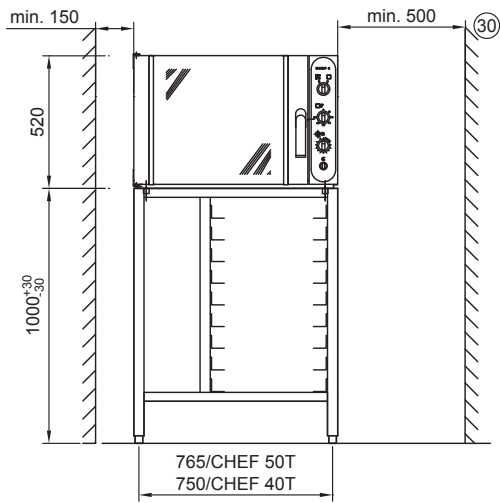

- (2) R 3/4", CHEF 40 / 50
- (4) R 3/8", CHEF 40 / 50
- (8) duct 30x50 mm

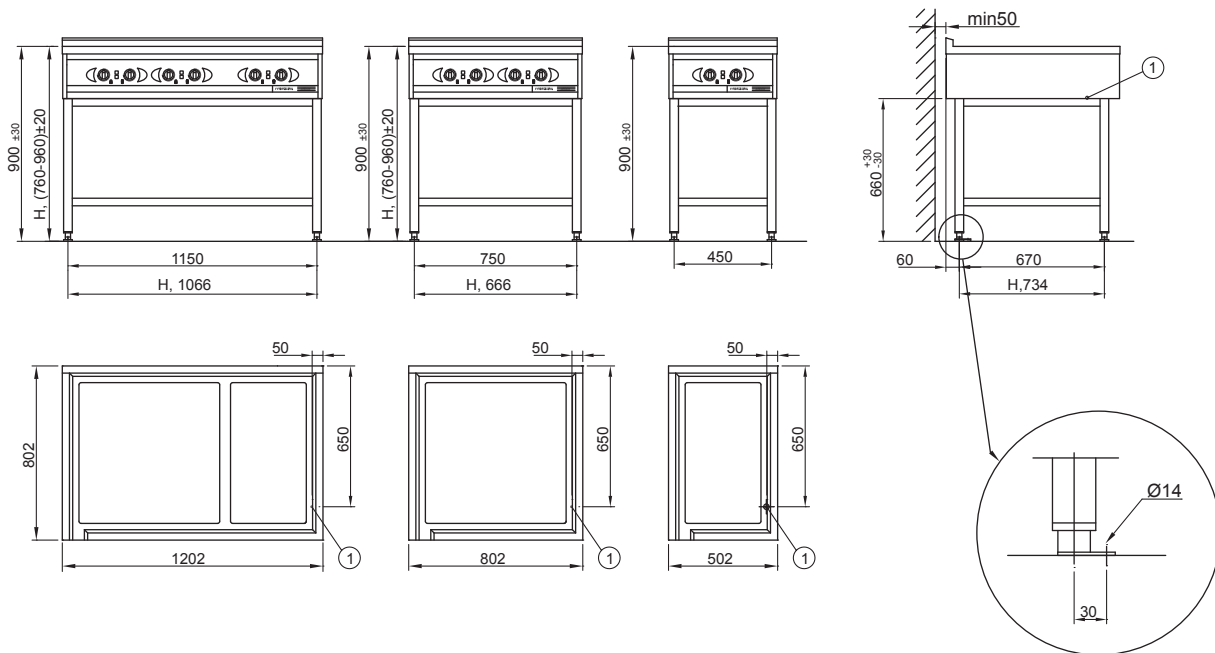
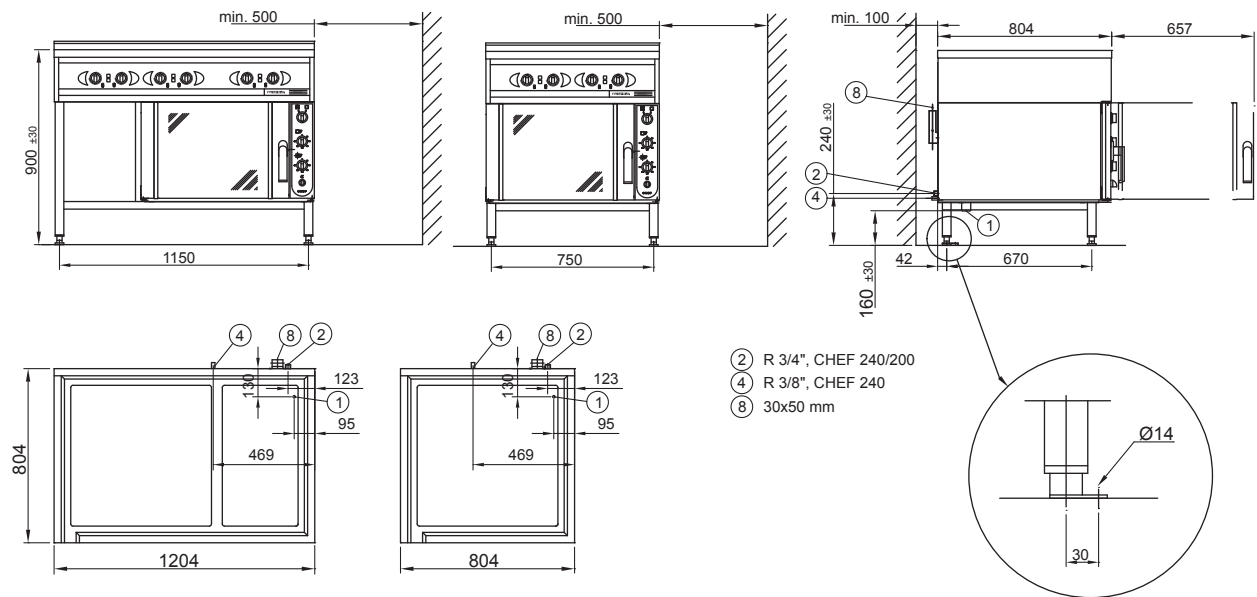

## METOS ARDOX TABLETOP

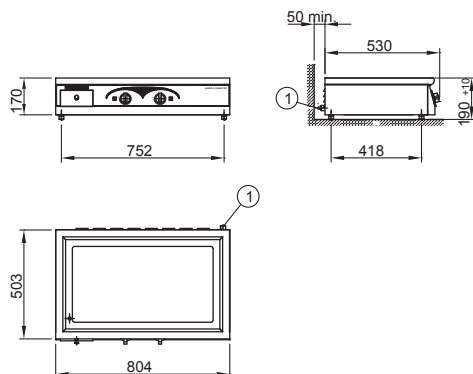

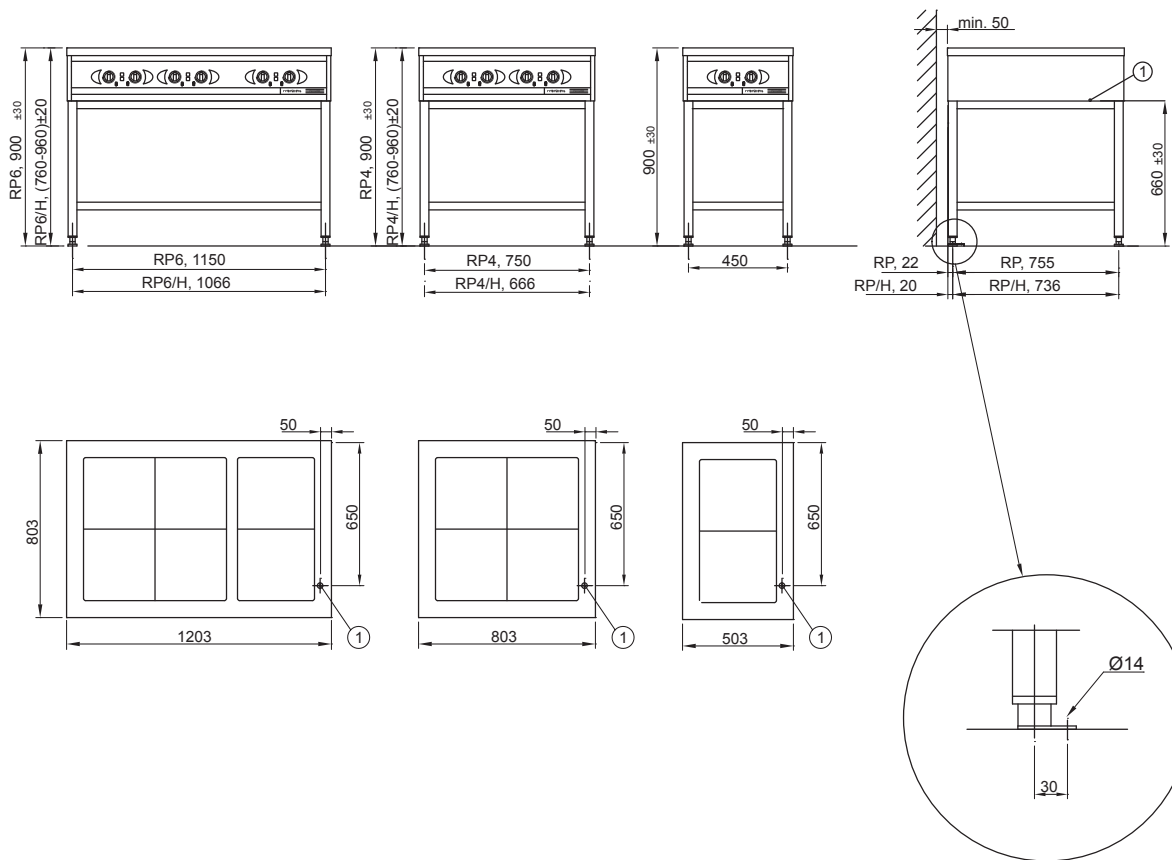
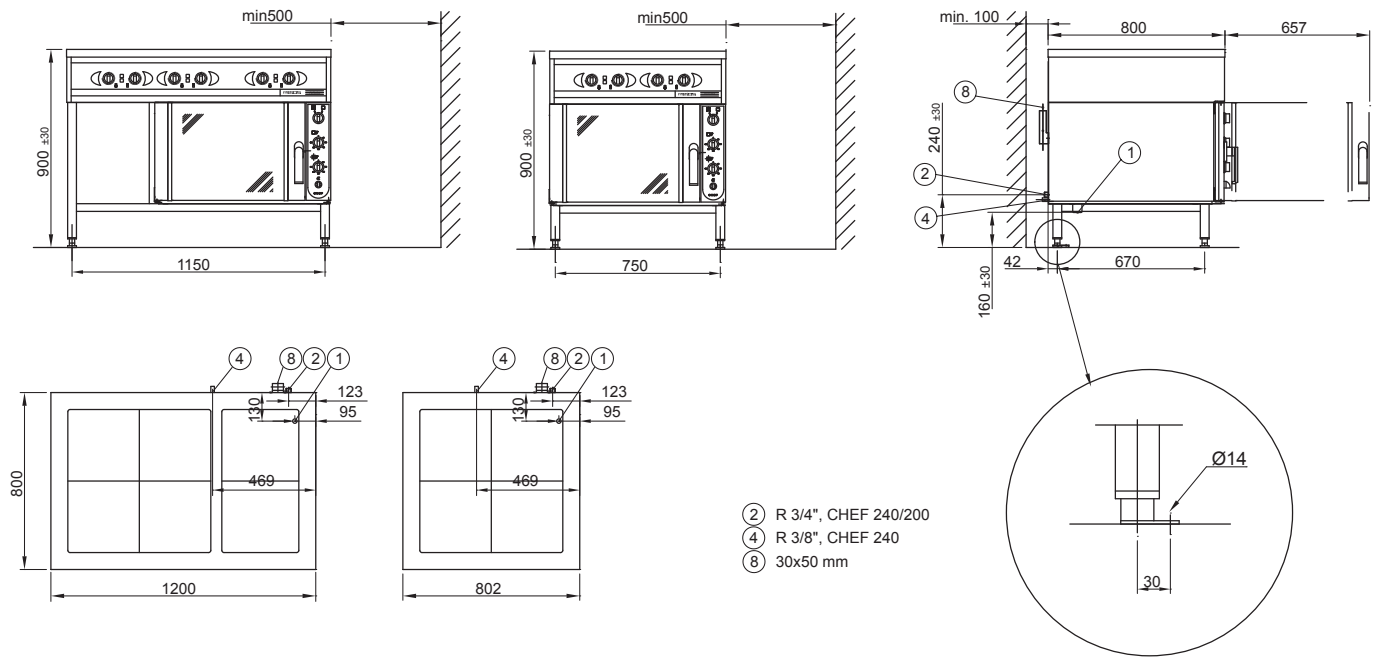

# METOS MINOR

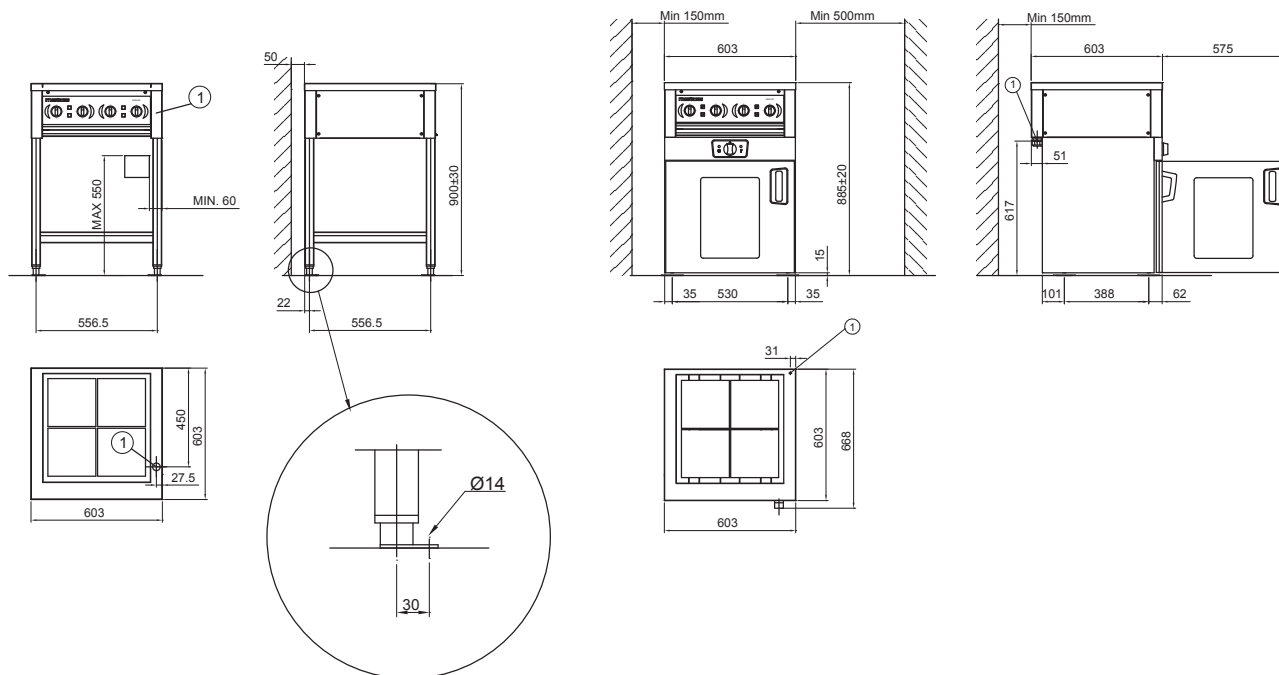

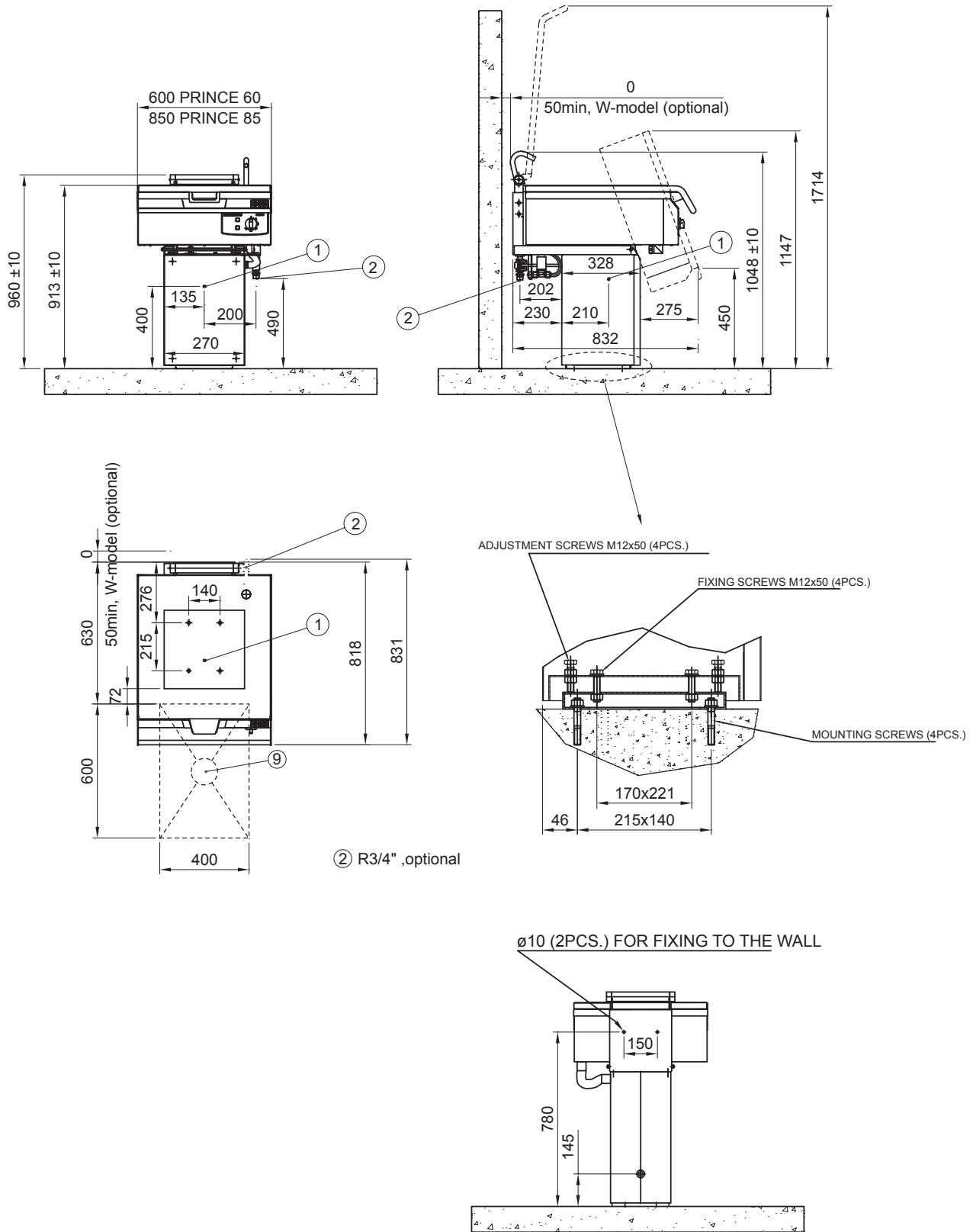

# METOS PRINCE H

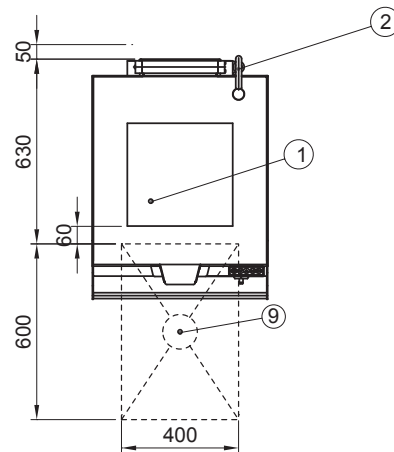
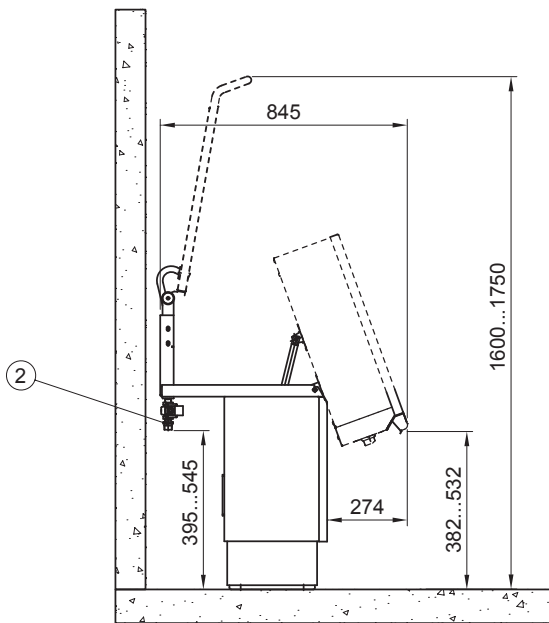
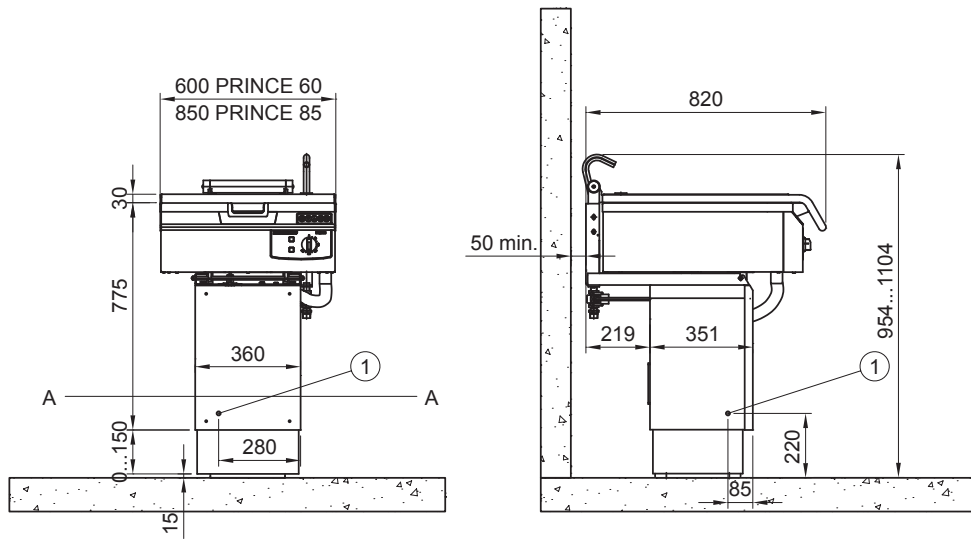

② R3/4" ,optional

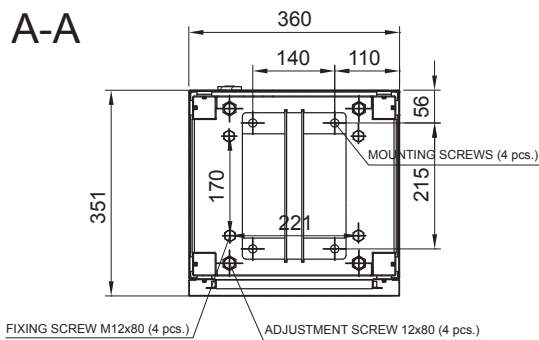

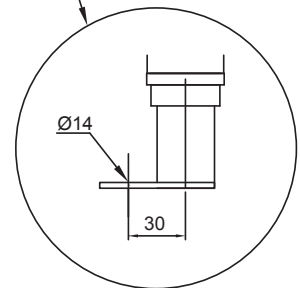
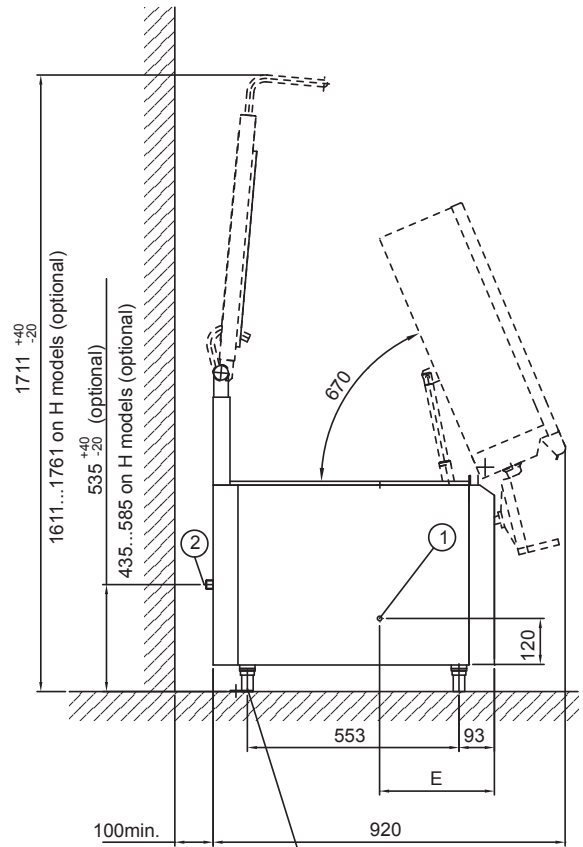
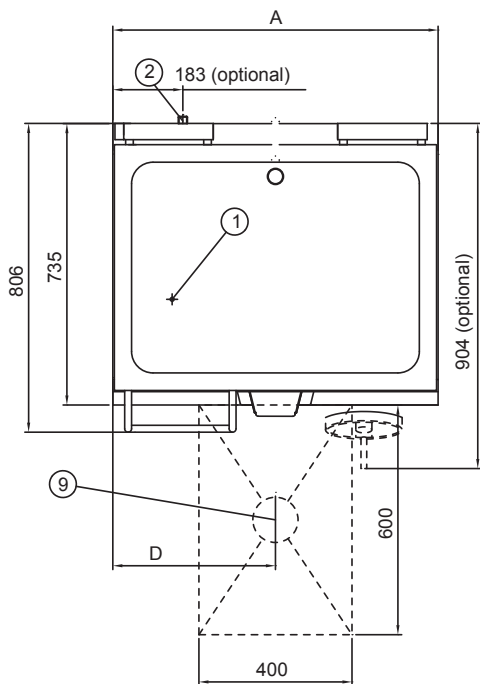
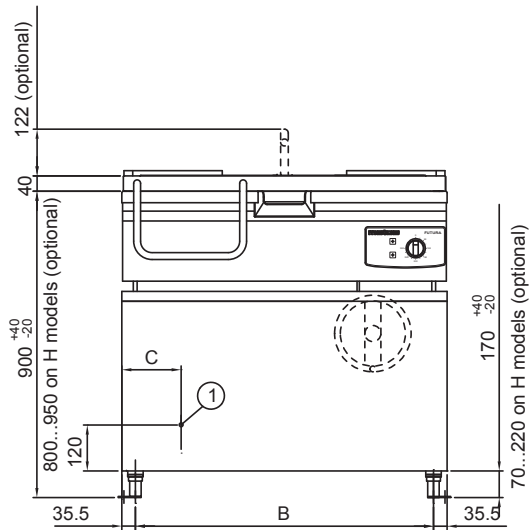

② R3/4", optional

Metos	A	B	C	D	E
Futura 60	600	529	120	300*	225
Futura 85	850	779	200	425	225
Futura 110	1100	1029	230	550	225

\* manual tilting 200 mm



# METOS DROP-IN WATER DISPENSER

## One-sided

drop basin

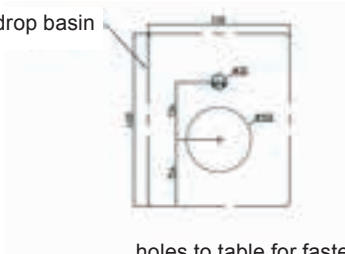

holes to table for fastening  
faucet and drainage

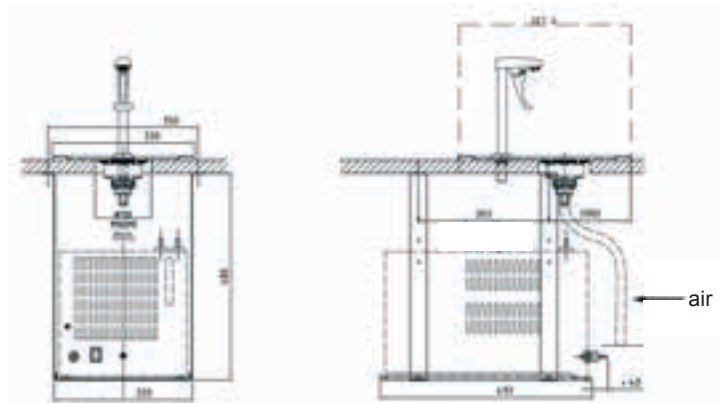

cooling unit  
ensure sufficient ventilation

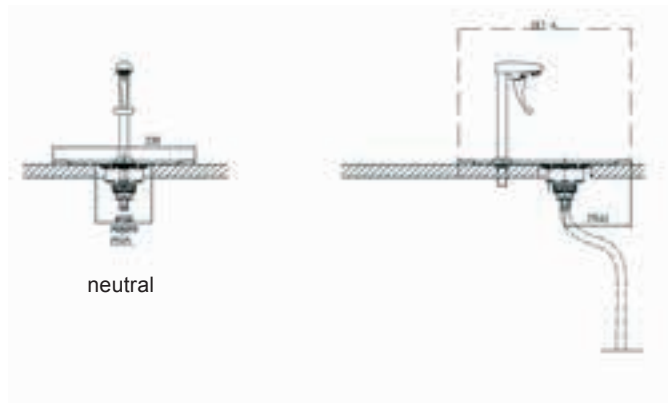

neutral

## Two-sided

drop basin

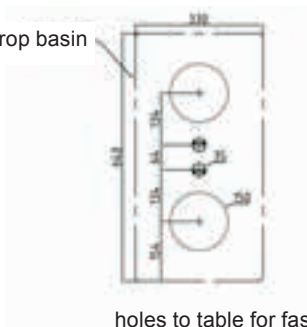

holes to table for fastening  
faucet and drainage

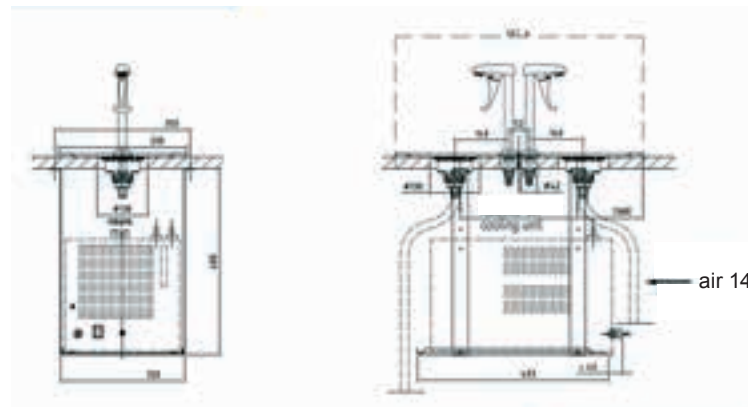

cooling unit  
ensure sufficient ventilation

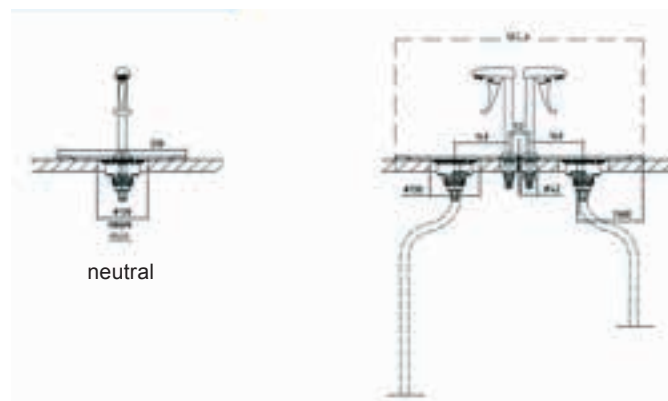

neutral

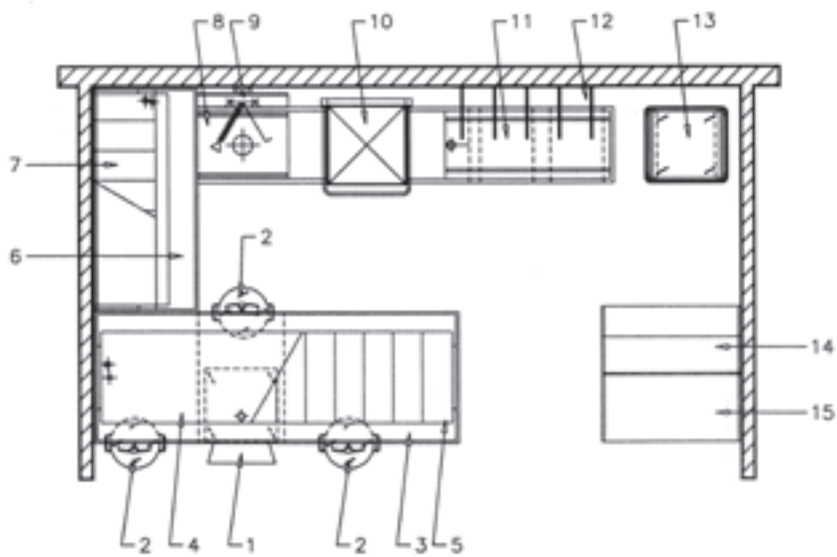
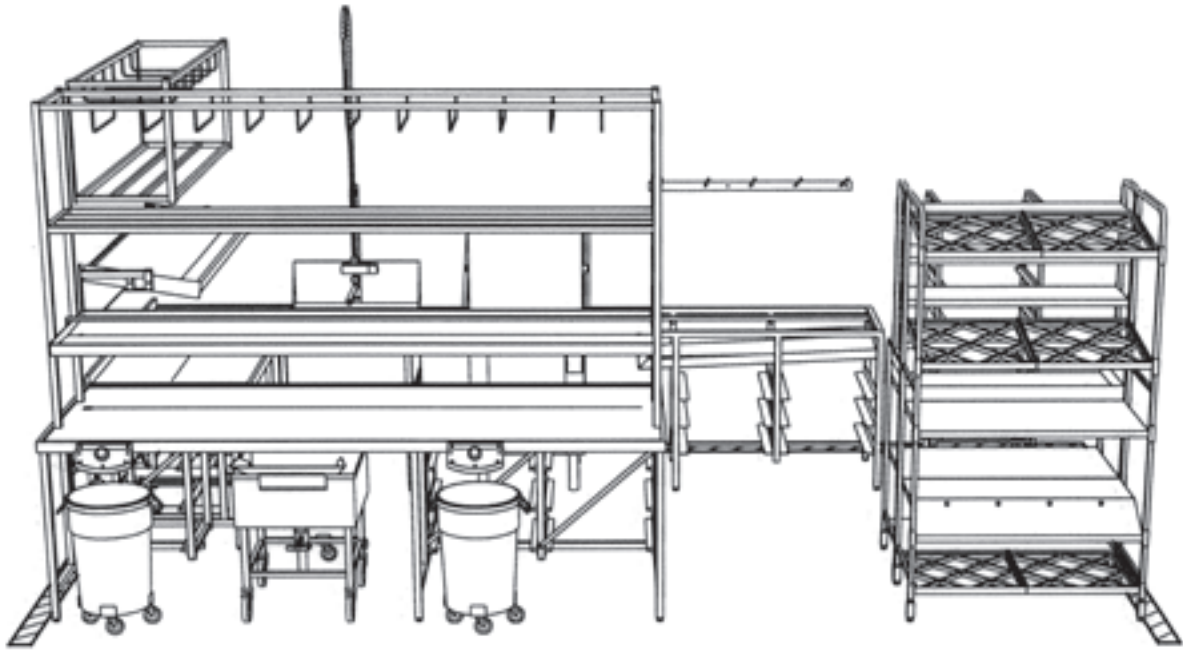

## Table service - pre-sorted goods - accumulated dishwashing

The serving staff place the dirty goods on the sorting bench, which is complete with a sorting shelf, a rack for empty baskets and guide rail sections for accumulation. The cutlery goes directly into the cutlery basket in the cutlery trolley, leftovers are scraped off the plates with the scraper and the plates are stacked on the left side of the bench. Glasses and cups are sorted directly into baskets on the sorting shelf.

The baskets are tilted towards the serving staff and when the basket is full, it is tilted over towards the dishwashing room. The Steward takes the full basket, puts it in the guide rail sections under the bench for accumulation, and replaces it with a clean empty one. Other dirty items, like pots, bowls and special types of glasses are placed on the right side of the bench. The special types of glasses are sorted into baskets on the sorting shelf (pos. 7) which is also used for sorting from trolleys, for instance from room-service, banquet or breakfast. The Steward stacks and stores the plates on the sorting bench. The piles of plates can also be soaked in the basin line. The goods are sorted and accumulated during the intensive period and the dishwashing takes place later. The full glass baskets are then washed. Plates are placed into dishwashing baskets and washed.

When the cutlery is washed the second time in the dishwashing tray for cutlery, the Steward empties the tray onto the cutlery sorting rack with the handles towards him. In that way, he can sort the cutlery into cutlery boxes only touching the handles. The Steward places the clean goods on trolleys and transports them to the storage areas.

The equipment is situated to reduce the working area and to shorten the transportation - still there is a lot of room to place and sort the goods and to store empty baskets etc.

Pos	Qty	Art. nr	Description
1	1	4554620	Cutlery soak trolley Nordien 245
	1	4554622	Cutlery chute Nordien 263
2	3	4551222	Waste trolley Nordien 217, with castors
3	1	4552270	Sorting unit Nordien 640-5-50-642-644,2805mm
	2	4551910	Scraper Nordien 421
4	1		included in pos 3
5	1		included in pos 3
6	1	4552188	Sorting table Nordien 600V-3-46,1719mm,wall
7	1	4552286	Sorting shelf Nordien 650-3, 1619mm, wall type
	1	4552160	Basket rack Nordien 501-3,1679mm,wallmounted
	1	4552118	Pair of brackets Nordien 654, for 1 sort.shelf
8	1	4552320	Pre-wash unit Nordien 700-6-3 ,600+300mm
	1		included in 8
9	1		Shower
10	1		Dishwashing machine
11	1	4552348	Drying line Nordien 750-2,1600mm
12	1	4552168	Cassette holder Nordien 502-2,1120mm,wallmounted
13	1	4554314	Basket trolley Nordien BAT-8 N-S
14	1	4551340	Cutlery rack Nordien 917
15	1	4551068	Serving rack Nordien 955, for 46x46 baskets

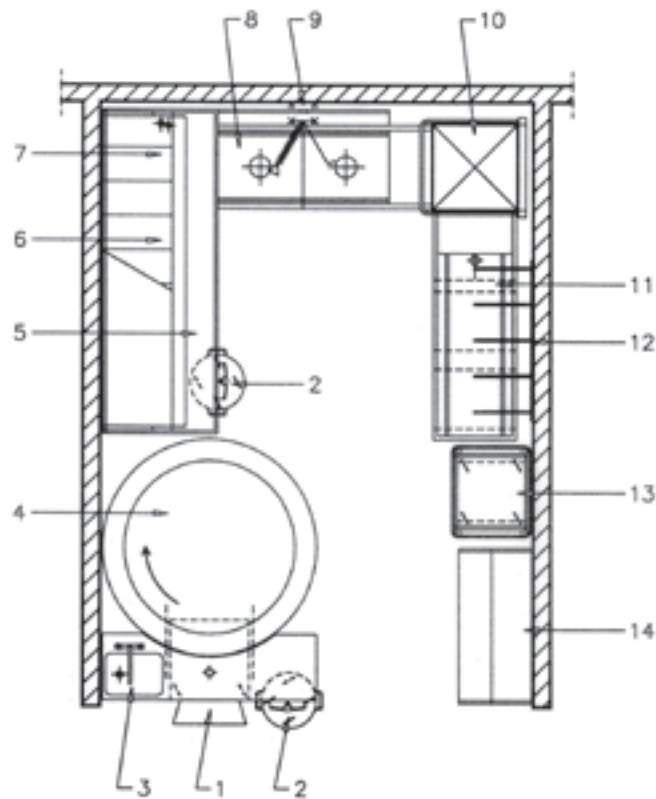
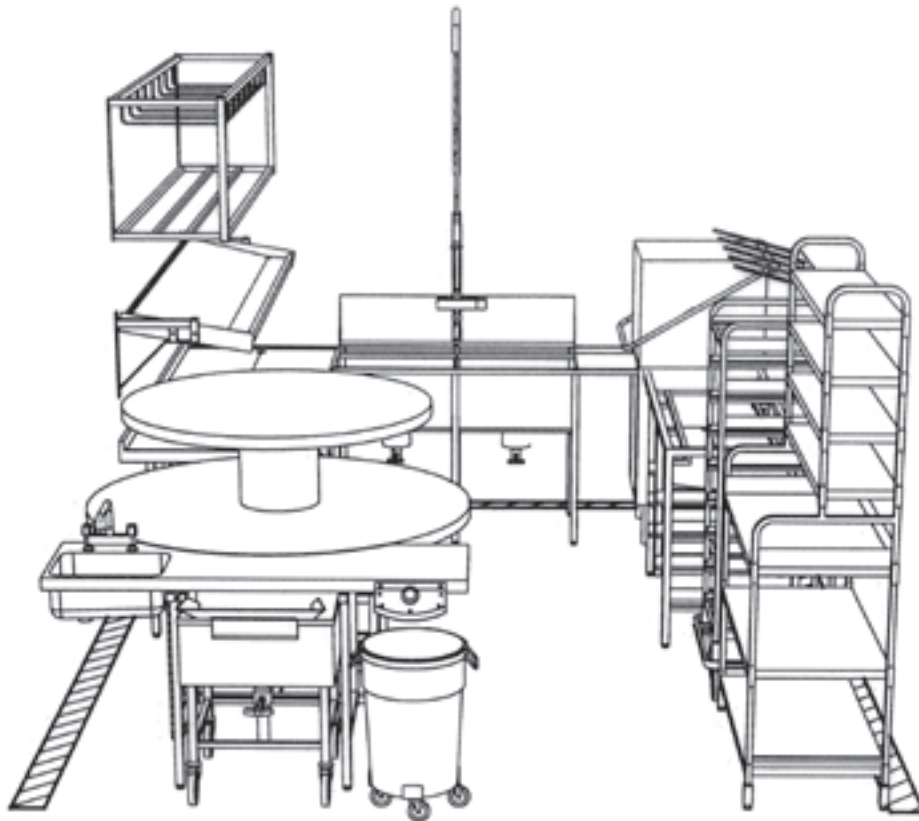

## RESTAURANT 100-400 SEATS

### Tableservice - pre-sorted goods - accumulated dishwashing

The Serving staff place the dirty goods on the two-level carousel; glasses and cups on the upper level, plates and other crockery on the lower level. The cutlery goes directly into the cutlery basket in the cutlery trolley. Leftovers are scraped off the plates with a scraper and stacked on the lower level of the carousel. Ice and slops are poured into the sink. The Steward stands by the sorting bench and uses the sorting shelf to sort glasses and cups from the carousel into baskets. When the baskets are full, they are placed on the guide rail sections under the bench. Plates and other crockery are stacked on the sorting bench or soaked in the basin line. In this way, the goods can be accumulated during the busy working hours such as lunchtime. The big capacity of the carousel makes it possible to work the dishwashing area more evenly regardless of the ups and downs in the restaurant. The goods are sorted and accumulated during the intensive period and the dishwashing takes place later. The full glass baskets are then washed. Plates are placed into dishwashing baskets and washed. The Steward places the clean goods on trolleys and transports them to the storage areas.

The big capacity of the carousel makes it possible to work in a very small area - even for a restaurant with a large variety of glasses and crockery. The equipment is situated to reduce the working area and to shorten the transportation. Still there is a lot room to place and sort the goods and to store empty baskets and plate cassettes.

Pos	Qty	Art. nr	Description
1	1	4554620	Cutlery soak trolley Nordien 245
	1	4554622	Cutlery chute Nordien 263
2	3	4551222	Waste trolley Nordien 217, with castors
3	1		included in pos. 4
	1	4551910	Scraper Nordien 421
4	1	4552354	Carousel 810-1H Nordien tray support, sink right
5	1	4552194	Sorting table Nordien 600V-4-50,2262mm,wall
6	1	4552288	Sorting shelf Nordien 650-4, 2162mm, wall type
	1	4552118	Pair of brackets Nordien 654, for 1 sort.shelf
7	1	4552162	Basket rack Nordien 501-4,2222mm,wallmounted
8	1	4552332	Pre-wash unit Nordien 700D-6-3, 2x600+300mm
9	1		included in 8
	1		Shower
10	1		Dishwashing machine
11	1	4552348	Unloading table Nordien 750-2,1600mm
12	1	4552168	Cassette holder Nordien 502-2,1120mm,wallmounted
13	1	4554446	Basket trolley Metos BAT-8-46 N-S
14	1	4551068	Serving rack Nordien 955, for 46x46 baskets

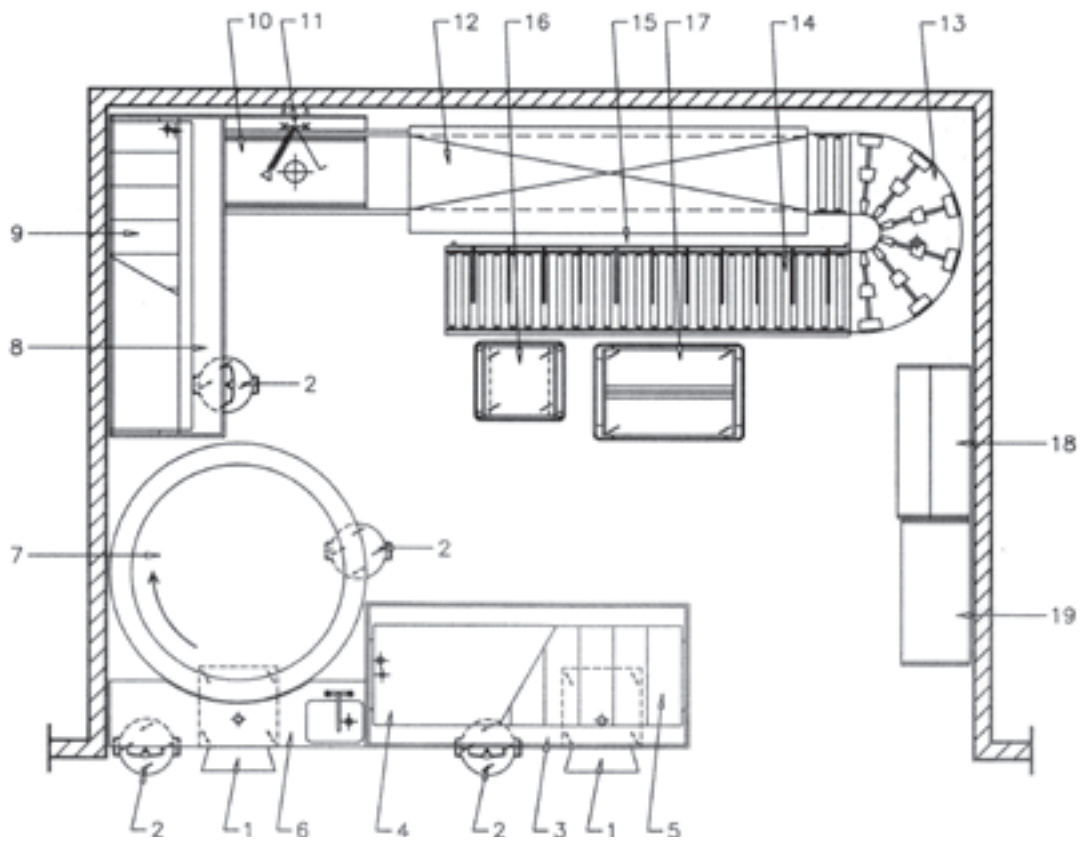
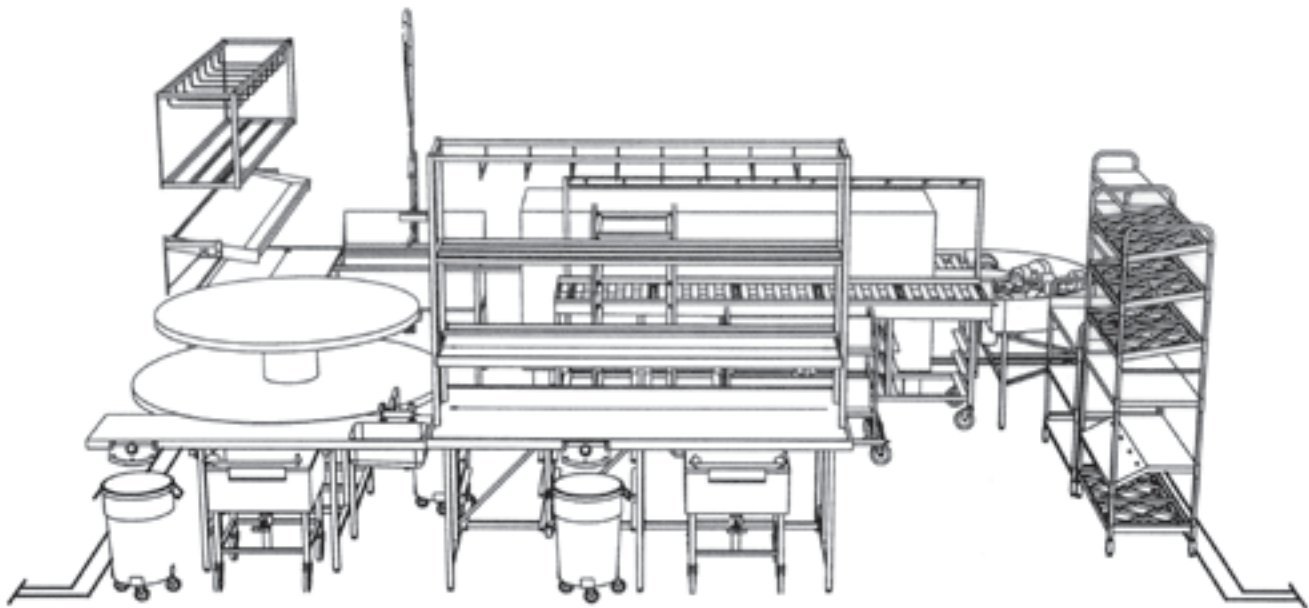

# RESTAURANT 300 - 500 SEATS

## Table service - pre-sorted goods - accumulated dishwashing

The serving staff place the goods as follows:

The cutlery goes directly into cutlery baskets in the cutlery trolley. Cups and the most frequent glasses are pre-sorted directly into baskets on the sorting shelf. The rest of the glasses are put on the upper level of the carousel. Leftovers are scraped off the plates with the scraper and the plates are stacked on the lower level of the carousel. When the baskets with pre-sorted glasses are full, they are stored on the guide rail sections under the bench - or if necessary, on a trolley, to be washed later on. The full baskets are replaced with empty ones from the rack above the shelf. The glasses on the upper level of the carousel are sorted directly into baskets on the sorting shelf (pos. 9) and when they are full they are stored on the guide rail sections under the bench.

The plates are stacked and stored on the sorting bench (pos. 8) or soaked in the basin line. In this way, the goods are being accumulated during the intensive periods, such as lunchtime. When the intensive period is over, the full glass baskets are washed. Plates are placed into dishwashing baskets, pre-rinsed and washed.

When the cutlery is washed the second time in the dishwashing tray for cutlery, the Steward empties the tray onto the cutlery sorting rack with the handles towards him - in this way he can sort all the cutlery into cutlery boxes only touching the handles. The clean cutlery can then be stored on the cutlery rack or transported for storing elsewhere. The Steward places the clean goods on trolleys and transports them to the storage areas. This dishwashing area can be handled by one man in a big restaurant with a large variety of glasses and crockery. The 180° turntable makes it possible to use the area in front of the machine and it also reduces unnecessary movement for the Steward. He can load and empty the machine from the same place.

Pos	Qty	Art. nr	Description
1	2	4554620	Cutlery soak trolley Nordien 245
	2	4554622	Cutlery chute Nordien 263
2	4	4551222	Waste trolley Nordien 217, with castors
3	1	4552278	Sorting unit Nordien 640-4-46-642-644,2262mm
	1	4551910	Scraper Nordien 421
4	1		included in pos. 3
5	1		included in pos. 3
6	1		included in pos. 7
	1		Water mixer
	1	4551910	Scraper Nordien 421
7	1	4552360	Carousel 810-2H Nordien tray support, sink right
8	1	4552192	Sorting table Nordien 600V-4-46,2262mm,wall
9	1	4552288	Sorting shelf Nordien 650-4, 2162mm, wall type
	1	4552162	Basket rack Nordien 501-4,2222mm,wallmounted
	1	4552118	Pair of brackets Nordien 654, for 1 sort.shelf
10	1	4552316	Pre-wash unit Nordien 700-11-3, 1100+300mm
11	1		included in pos. 10
	1		Shower
12	1		Dishwashing machine
13	1	4552102	Conv.curve 180 Nordien 445, motor-driven
	1	4552106	Roller connectionNordien 454
14	1	4552144	Drying line Nordien 460-5, 2635mm, on wheels
15	1	4552180	Cassette holder Nordien 502T-5, 2535mm, fast
16	1	4554446	Basket trolley Metos BAT-8-46 N-S
17	1	4554532	Cassette trolley Nordien PCT-12 low N-S
18	1	4551340	Cutlery rack Nordien 917
19	1	4551068	Serving rack Nordien 955, for 46x46 baskets

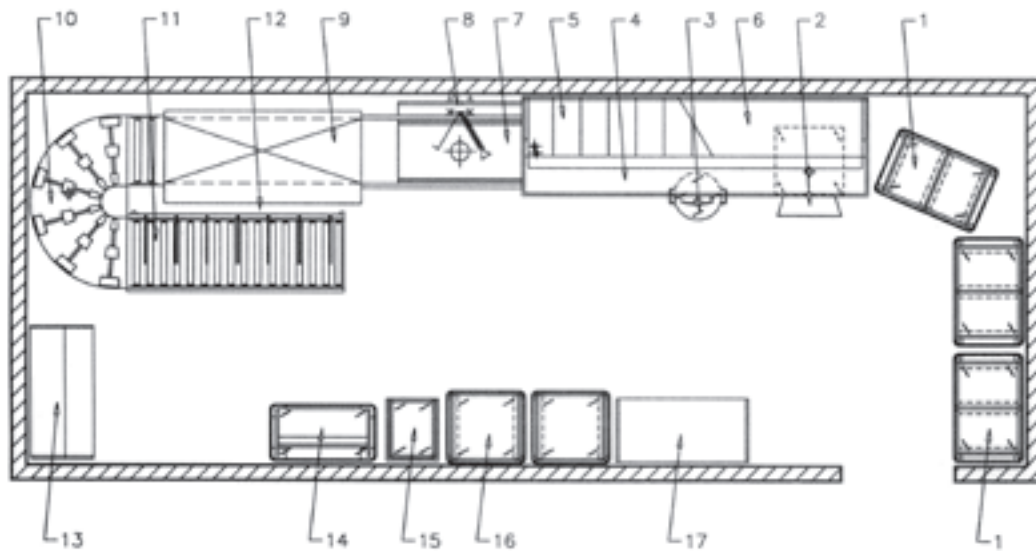
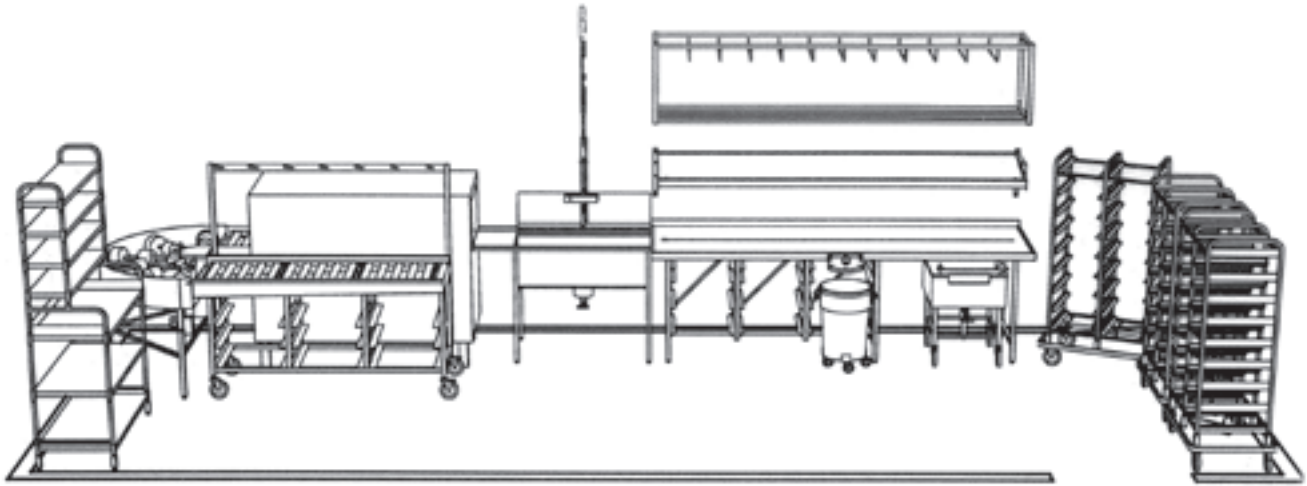



## SELF SERVICE RESTAURANT 200 - 400 SEATS

### Tray service - accumulated dishwashing

The guests or the staff leaves the dirty goods on trays in a tray trolley, which later on is taken to the dishwashing room. The Steward scrapes the leftovers off the plates with the scraper and stacks them on the bench. Glasses and cups are sorted into dishwashing baskets on the sorting shelf. When the baskets are full, they are put on the guide rail sections under the bench for accumulation. The cutlery goes directly into cutlery baskets in the cutlery trolley and the trays are stacked on the bench. In this way, the goods can be accumulated during the intensive period and washed later on. When the intensive period is over, the full glass baskets are washed, plates are placed into dishwashing baskets, pre-rinsed and washed.

The Steward then places the clean goods on the trolleys and transports them to the storage areas.

When the cutlery has been washed the second time in the dishwashing tray for cutlery, the Steward empties the tray onto the cutlery sorting rack with the handles towards him. In that way, he can sort the cutlery into cutlery boxes only touching the handles.

This dishwashing area can, with a minimum of staff, handle the dishwashing for a big lunch restaurant or staff canteen. By accumulating the dirty goods, during the intensive periods, the staff can balance the work more evenly during the working hours. The 180° turntable makes it possible to use the area in front of the machine and it also reduces unnecessary movement for the Steward - he can load and empty the machine from the same place.

Pos	Qty	Art. nr	Description
1	4-6	4554454	Tray trolley Metos TRT-20 N-S
2	1	4554620	Cutlery soak trolley Nordien 245
	1	4554622	Cutlery chute Nordien 263
3	1	4551222	Waste trolley Nordien 217, with castors
4	1	4552198	Sorting table Nordien 600V-5-50,2805mm,wall
	1	4551910	Scraper Nordien 421
5	1	4552290	Sorting shelf Nordien 650-5, 2705mm, wall type
	1	4552118	Pair of brackets Nordien 654, for 1 sort.shelf
6	1	4552164	Basket rack Nordien 501-5,2765mm,wallmounted
7	1	4552316	Pre-wash unit Nordien 700-11-3, 1100+300mm
8	1		included in pos. 7
	1		Shower
9	1		Dishwashing machine
10	1	4552102	Conv.curve 180 Nordien 445, motor-driven
	1	4552106	Roller connectionNordien 454
11	1	4552140	Drying line Nordien 460-3, 1585mm, on wheels
12	1	4552176	Cassette holder Nordien 502T-3, 1660mm, fast
13	1	4551340	Cutlery rack Nordien 917
14	1	4554325	Cassette trolley Nordien PCT-4 N-S
15	1	4554320	Tray dispenser trolley Nordien TDT N-S
16	2	4554314	Basket trolley Nordien BAT-8 N-S
17	1	4551348	Storage rack Nordien 921

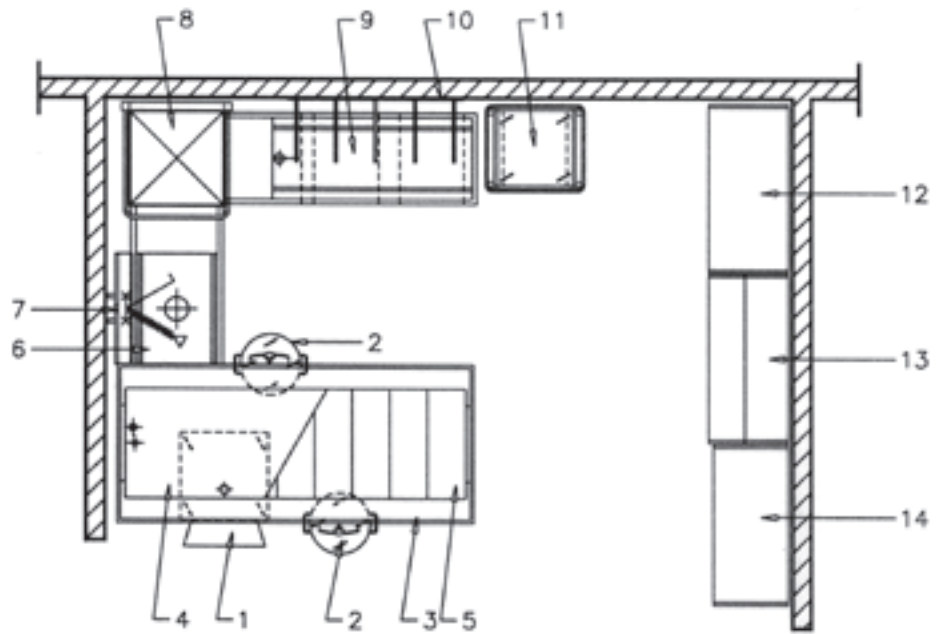
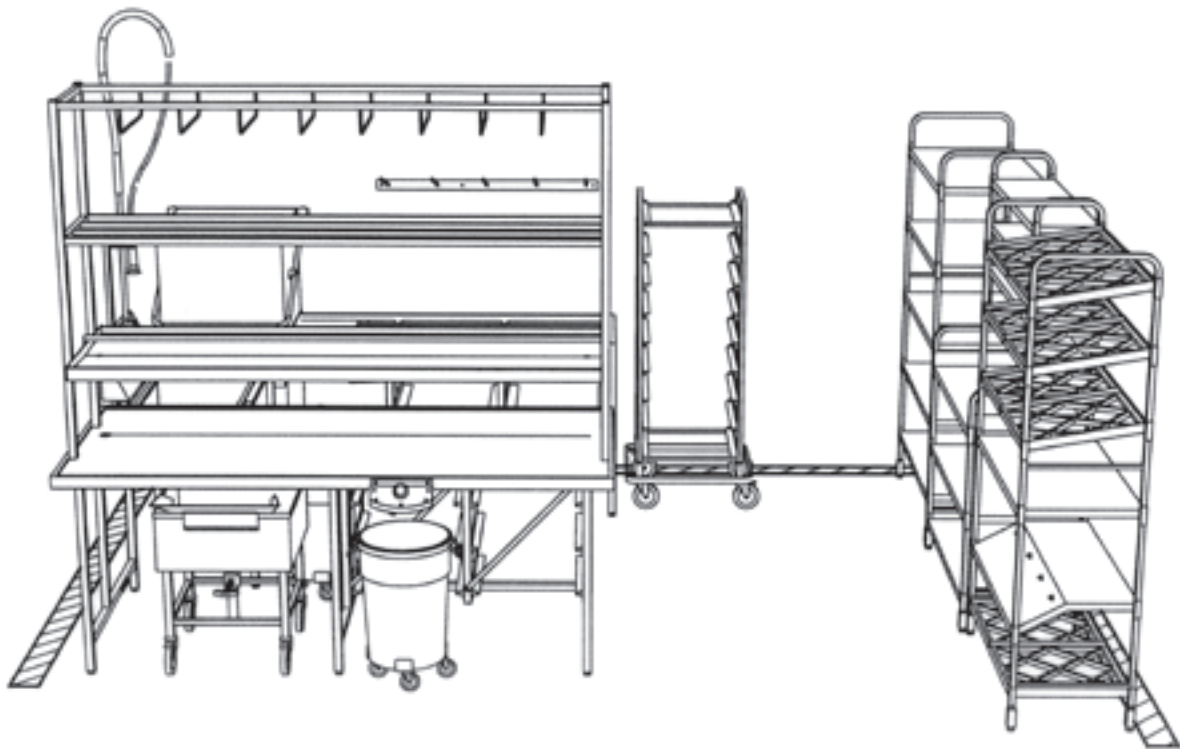

## Table service - pre-sorted goods - continuous dishwashing

The serving staff place the dirty goods on the sorting bench, which is provided with a sorting shelf and a rack for empty baskets. The cutlery goes directly into cutlery baskets in the cutlery trolley. Leftovers are scraped off the plates with the scraper and the plates are stacked on the bench. Glasses and cups are pre-sorted into dishwashing baskets on the sorting shelf. The baskets are tilted towards the serving staff and when the baskets are full, the serving staff tilts them towards the dishwashing area. The Steward takes the full glass baskets and puts them through the dishwashing machine, he replaces the full basket with an empty one. The Steward places the plates into plate baskets, pre-rinses them and puts them through the dishwashing machine.

When the cutlery is washed the second time in the dishwashing tray for cutlery, the Steward empties the tray on the cutlery sorting rack with the handles towards him. In that way, he can sort the cutlery into cutlery boxes only touching the handles. The clean goods are placed on trolleys and transported to the storage areas.

This fairly small dishwashing area still provides enough dumping area for dirty goods on the dumping bench. This enables the serving staff to quickly return to their guests. The Steward gets good help from the serving staff as they pre-sort the glasses and cups into baskets pile the plates and put the cutlery directly into cutlery baskets.

Pos	Qty	Art. nr	Description
1	1	4554620	Cutlery soak trolley Nordien 245
	1	4554622	Cutlery chute Nordien 263
2	2	4551222	Waste trolley Nordien 217, with castors
3	1	4552280	Sorting unit Nordien 640-5-46-642-644,2805mm
	2	4551910	Scraper Nordien 421
4	1		included in 640-5-46-642-644
5	1		included in 640-5-46-642-644
6	1	4552320	Pre-wash unit Nordien 700-6-3 ,600+300mm
7	1		included in 700-6-3
	1		Shower
8	1		Dishwashing machine
9	1	4552348	Unloading table Nordien 750-2,1600mm
10	1	4552168	Cassette holder Nordien 502-2,1120mm,wallmounted
11	1	4554446	Basket trolley Metos BAT-8-46 N-S
12	1	4551348	Storage rack Nordien 921
13	1	4551340	Cutlery rack Nordien 917
14	1	4551068	Serving rack Nordien 955, for 46x46 baskets

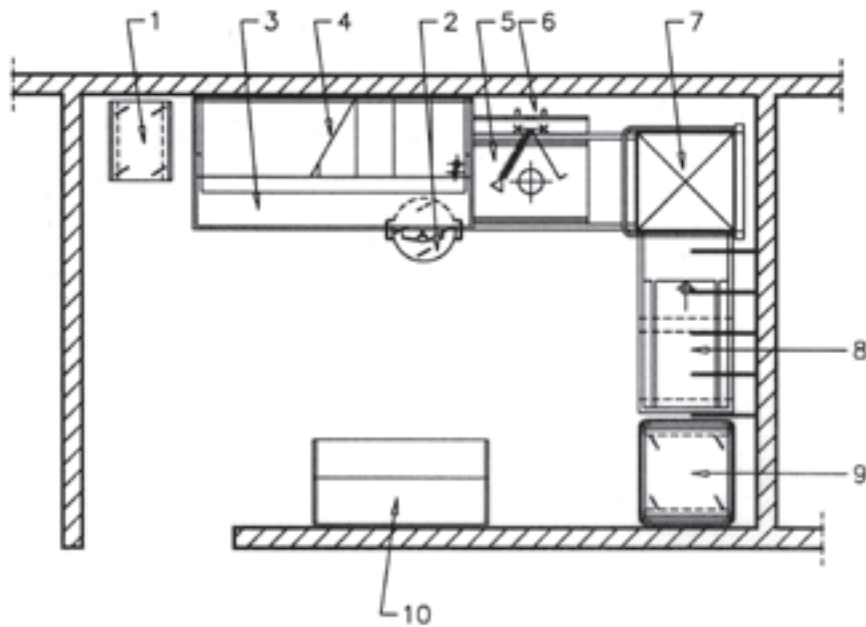
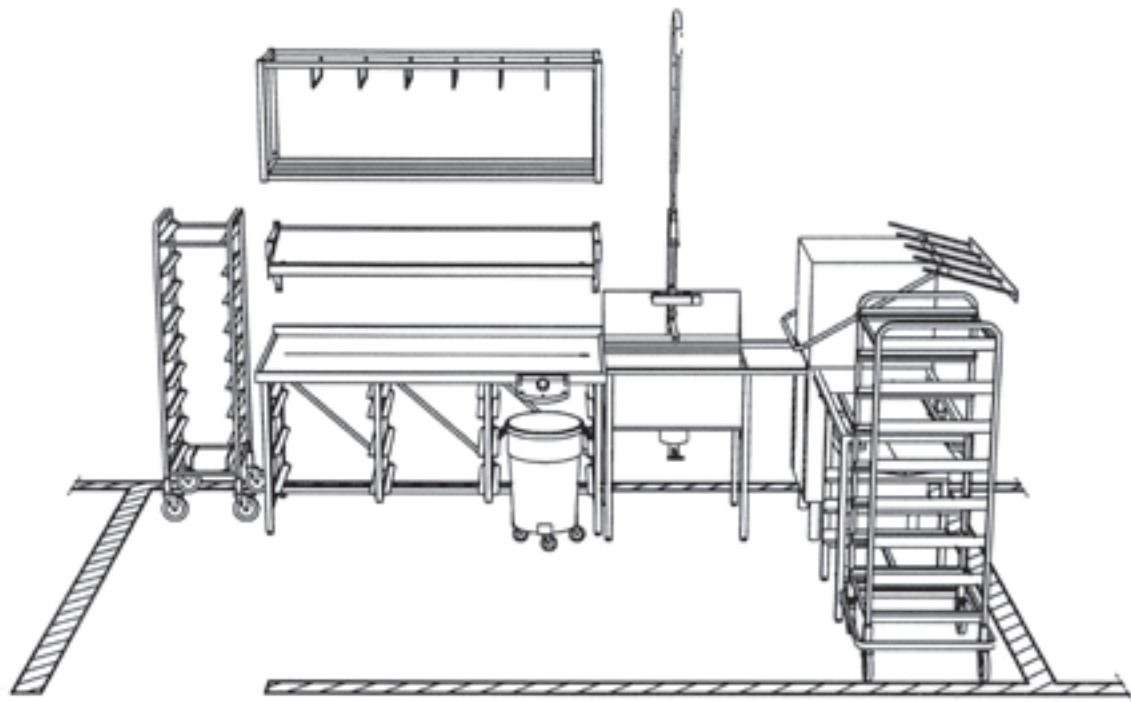

## SELF-SERVICE RESTAURANT 50 - 200 SEATS

### Tray service - continuous dishwashing

The dirty goods are placed on trays in tray trolleys, which are later transported into the dishwashing area. The Steward sorts the plates, cutlery and trays direct into baskets on the bench. Glasses and cups are sorted into baskets on the sorting shelf. When a basket is full, it is pre-rinsed and put into the dishwashing machine.

When the cutlery has been washed the second time in the dishwashing tray for cutlery, the Steward empties the tray on the cutlery sorting rack with the handles towards him. In that way, he can sort all cutleries into cutlery boxes, only touching the handles. The clean cutlery can then be stored on the sorting rack or transported together with other clean goods on trolleys to the storage area.

This small dishwashing area has got all the functions required for efficiently taking care of the dirty goods from the self-service restaurant as well as having space for trolleys.

Pos	Qty	Art. nr	Description
1	1	4554340	Tray trolley Nordien TRT-10 N-S
2	1	4551222	Waste trolley Nordien 217, with castors
3	1	4552190	Sorting table Nordien 600V-3-50,1719mm,wall
	1	4551910	Scraper Nordien 421
4	1	4552286	Sorting shelf Nordien 650-3, 1619mm, wall type
	1	4552118	Pair of brackets Nordien 654, for 1 sort.shelf
	1	4552160	Basket rack Nordien 501-3,1679mm,wallmounted
5	1	4552320	Pre-wash unit Nordien 700-6-3 ,600+300mm
6	1		included in pos. 5
	1		Shower
7	1		Dishwashing machine
8	1	4552346	Unloading table Nordien 750-1,1100mm
9	1	4554314	Basket trolley Nordien BAT-8 N-S
10	1	4551340	Cutlery rack Nordien 917

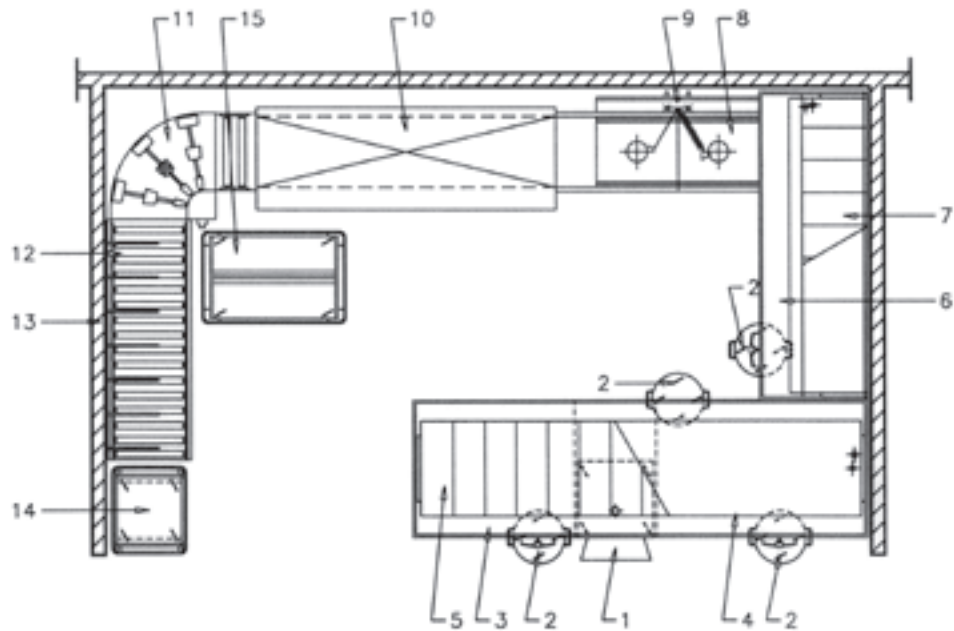
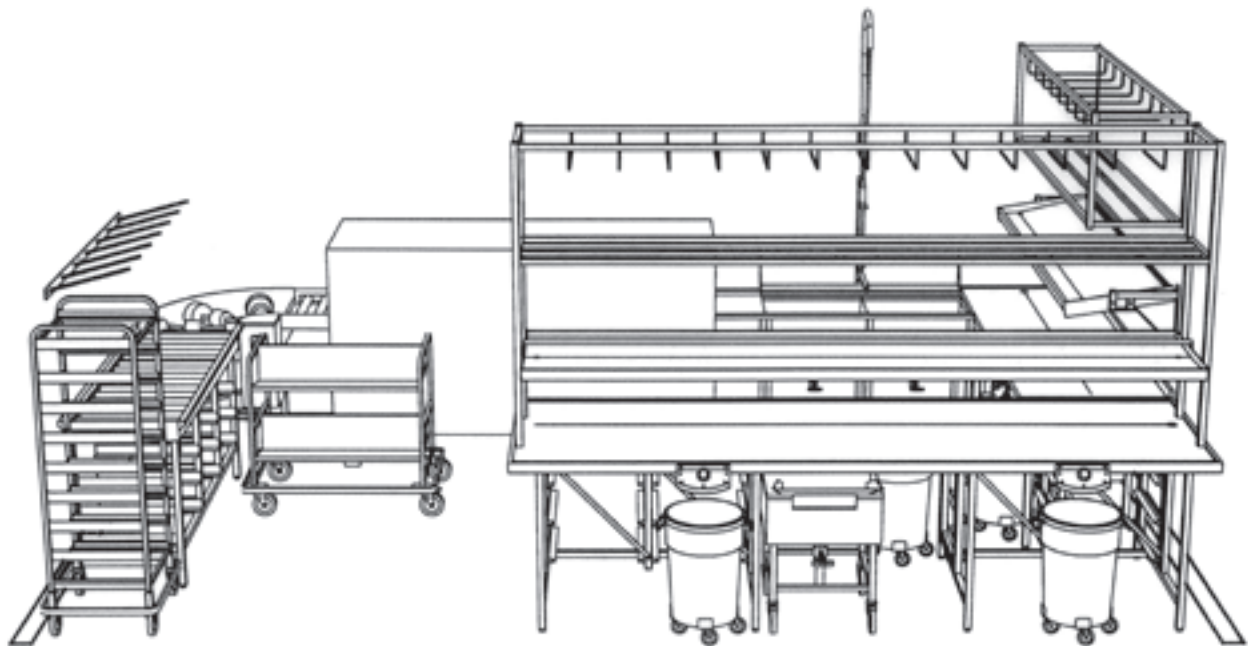

## TABLE SERVICE 200 - 500 SEATS

### Table service - pre-sorted goods - accumulated dishwashing

The serving staff place the dirty goods on the delivery bench, which is complete with a sorting shelf, a rack for empty baskets and guide rail sections for accumulation. The cutlery goes directly in the cutlery basket in the cutlery trolley. Leftovers are scraped off the plates with the scraper and the plates are stacked on the right side of the bench. Glasses and cups are sorted directly into baskets on the sorting shelf. The baskets are tilted towards the serving staff and when the basket is full, it is tilted over towards the dishwashing area. The Steward takes the full basket and puts it on the guide rail sections under the bench for accumulation and replaces the full basket with an empty one. Other dirty items like pots, bowls and special types of glasses are placed on the left side of the bench.

The Steward piles and stores the plates on the sorting bench (pos. 6) The piles could also be soaked in the basin line. The goods are sorted and accumulated during the intensive period and the dishwashing takes place later. The full glass baskets are then washed, plates are placed into plate baskets, pre-rinsed and washed, etc. The Steward places the clean goods onto trolleys to be transported to the storage areas.

This dishwashing lay-out gives the serving staff a lot of space to leave the dirty goods and it also gives a good sorting capacity on the separate sorting bench. The double basin line could be used for soaking and pre-washing. It could also be used for taking care of the pot wash. This layout is also suitable for banquets as it gives a lot of space for trolleys.

Pos	Qty	Art. nr	Description
1	1	4554620	Cutlery soak trolley Nordien 245
	1	4554622	Cutlery chute Nordien 263
2	3	4551222	Waste trolley Nordien 217, with castors
3	1	4552272	Sorting unit Nordien 640-6-50-642-644,3356mm
	2	4551910	Scraper Nordien 421
4	1		included in pos. 4
5	1		included in pos. 4
6	1	4552194	Sorting table Nordien 600V-4-50,2262mm,wall
	1	4551910	Scraper Nordien 421
7	1	4552288	Sorting shelf Nordien 650-4, 2162mm, wall type
	1	4552118	Pair of brackets Nordien 654, for 1 sort.shelf
	1	4552162	Basket rack Nordien 501-4,2222mm,wallmounted
8	1	4552332	Pre-wash unit Nordien 700D-6-3, 2x600+300mm
9	1		included in pos. 8
	1		Shower
10	1		Dishwashing machine
11	1	4552104	Conv.curve 90 Nordien 446, motor-driven
12	1	4552150	Drying line Nordien 465-3, 1585mm
13	1	4552170	Cassette holder Nordien 502-3,1660mm,wallmounted
14	1	4554446	Basket trolley Metos BAT-8-46 N-S
15	1	4554532	Cassette trolley Nordien PCT-12 low N-S

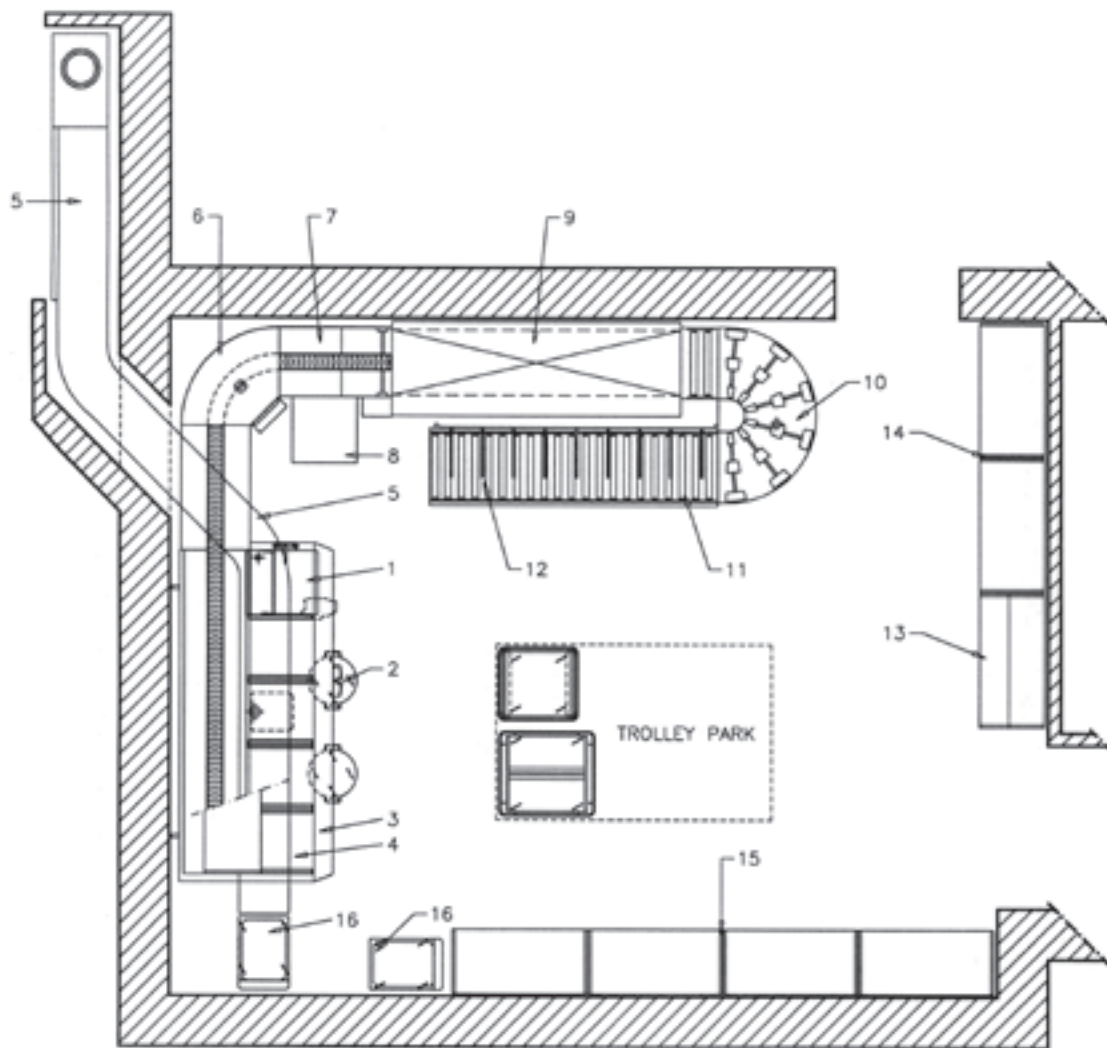



## Tray service - continuous dishwashing

The guests place their trays on the tray conveyor. The dry garbage is thrown in the waste ring at the beginning of the tray conveyor. The trays are then transported on the tray conveyor out to the dishwashing area. In the dishwashing room the cutlery is put directly in a cutlery basket in the cutlery soak unit. The leftovers are scraped off the plates with the scraper and the plates are then stacked in plate baskets. Glasses and cups are sorted into dishwashing baskets on the sorting table. The empty trays are automatically stacked in a tray dispenser trolley at the end of the tray conveyor.

When the dishwashing baskets are full, they are pushed onto the basket conveyor. The dishwashing baskets automatically move through the automatic pre-rinse tunnel in the curve, where they are pre-rinsed, and then go into the dishwashing machine to be washed. The trays are taken from the tray dispenser trolleys and placed into tray baskets on the tray loading table. When a tray basket is full, it is pushed onto the basket conveyor to be transported into the dishwashing machine.

The clean goods are placed on trolleys and then transported to the storage and restaurant areas.

Pos	Qty	Art. nr	Description
1	1	4552030	Cutlery unit Metos 5016, lifting mechanism
2	2	4551222	Waste trolley Nordien 217, with castors
	1	4551910	Scraper Nordien 421
3	1		Base unit system
	1		Conveyor extension
4	1		Basket shelf
5	1		Tray conveyor
6	1		Curve 90
	1		Pre-Rinse unit
7	1		Power unit
	2		Conveyor extension
8	1	4552038	Tray loading table Metos fold-down type
9	1		Dishwashing machine
10	1	4552102	Conv.curve 180 Nordien 445, motor-driven
11	1	4552142	Drying line Nordien 460-4, 2110mm, on wheels
12	1	4552178	Cassette holder Nordien 502T-4, 2200mm, fast
13	1	4551340	Cutlery rack Nordien 917
14	2	4551348	Storage rack Nordien 921
15	4	4551348	Storage rack Nordien 921
16	2	4554320	Tray dispenser trolley Nordien TDT N-S

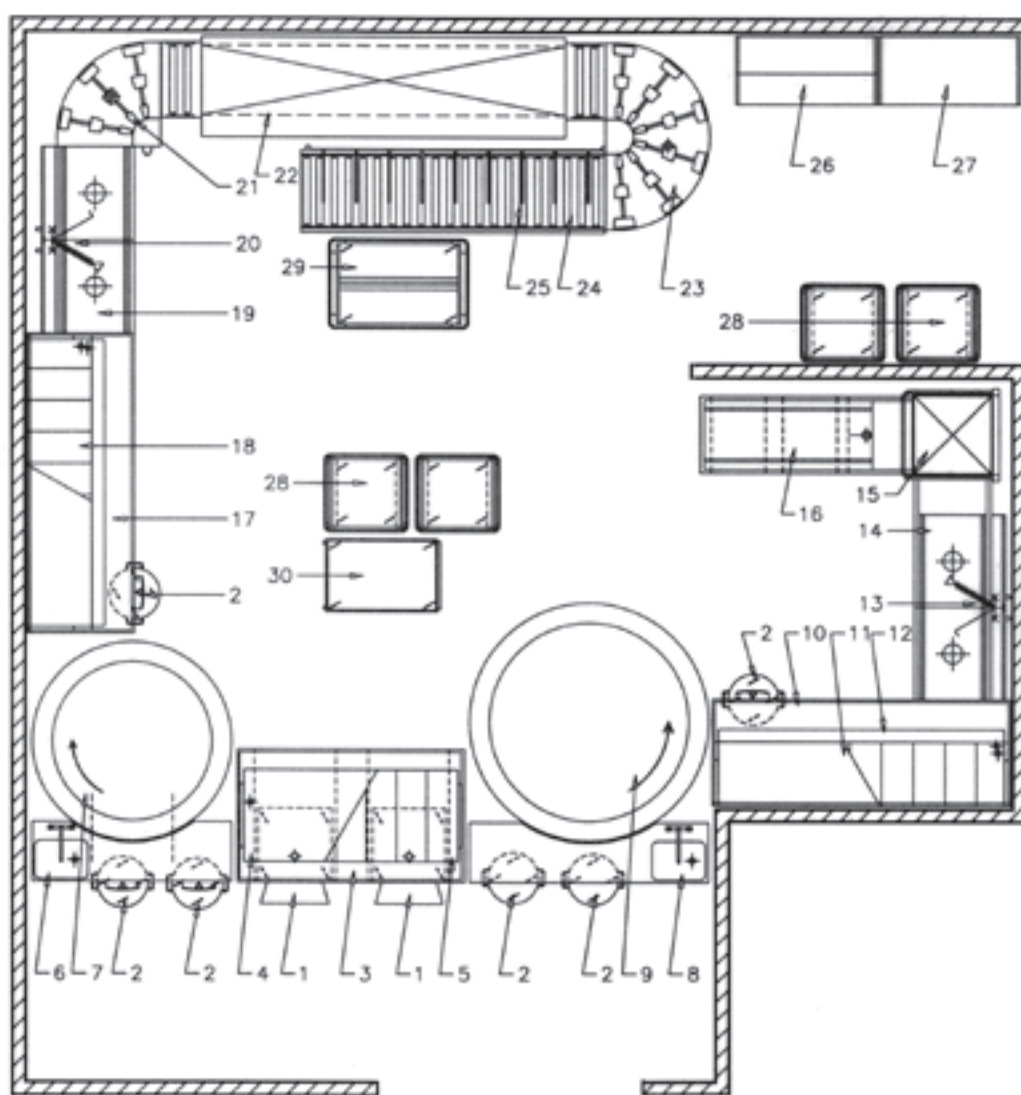

## RESTAURANT WITH UP TO 1000 SEATS

### Table service - continuous/accumulated dishwashing - separate glass washing

In this specific dishwashing area, the water quality demands a separate glass washing machine. The serving staff put the cutlery directly into cutlery baskets in the cutlery trolleys. Leftovers are scraped off the plates with the scrapers and the plates, as well as other crockery, are stacked on the upper and lower level of the left carousel. The most common glasses and cups are pre-sorted directly into baskets on the dumping bench and the sorting shelf (pos. 3 + 4). Other glasses are placed on the carousel to the right.

The plates are piled on the sorting bench (pos. 17) and then placed in dishwashing baskets, prerinsed and washed. Glasses are sorted into dishwashing baskets on the sorting bench (pos. 10) and sorting shelf (pos. 12) and washed when the

Pos	Qty	Art. nr	Description
1	2	4554620	Cutlery soak trolley Nordien 245
2	6	4554622	Waste trolley Nordien 217, with castors
3	1	4552266	Sorting unit Nordien 640-3-50-642-644,1719mm
4	1		included in pos. 3
5	1		included in pos. 3
6	1		included in pos. 7
	2	4551910	Scraper Nordien 421
7	1	4552356	Carousel 810-1V Nordien tray support, sink left
8	1		included in pos. 9
	1		Water mixer
9	1	4552360	Carousel 810-2H Nordien tray support, sink right
10	1	4552194	Sorting table Nordien 600V-4-50,2262mm,wall
	1	4552118	Pair of brackets Nordien 654, for 1 sort.shelf
11	1	4552162	Basket rack Nordien 501-4, 2222mm,wallmounted
12	1	4552288	Sorting shelf Nordien 650-4, 2162mm, wall type
13	1		included in pos. 14
14	1	4552332	Pre-wash unit Nordien 700D-6-3, 2x600+300mm
	1		Shower
15	1		Dishwashing machine
16	1	4552348	Drying line Nordien 750-2,1600mm
17	1	4552194	Sorting table Nordien 600V-4-50,2262mm,wall
18	1	4552288	Sorting shelf Nordien 650-4, 2162mm, wall type
	1	4552118	Pair of brackets Nordien 654, for 1 sort.shelf
	1	4552162	Basket rack Nordien 501-4, 2222mm,wallmounted
19	1	4552330	Pre-wash unit Nordien 700D-6-1, 2x600+100mm
20	1		included in pos. 20
	1		Shower
21	1	4552104	Conv.curve 90 Nordien 446, motor-driven
22	1		Dishwashing machine
23	1	4552102	Conv.curve 180 Nordien 445, motor-driven
	1	4552106	Roller connectionNordien 454
24	1	4552142	Drying line Nordien 460-4, 2110mm, on wheels
25	1	4552178	Cassette holder Nordien 502T-4, 2200mm, fast
26	1	4551340	Cutlery rack Nordien 917
27	1	4551348	Storage rack Nordien 921
28	4	4554314	Basket trolley Nordien BAT-8 N-S
29	1	4554532	Cassette trolley Nordien PCT-12 low N-S
30	1	4554292	Service trolley Nordien SET-75/2 N-S

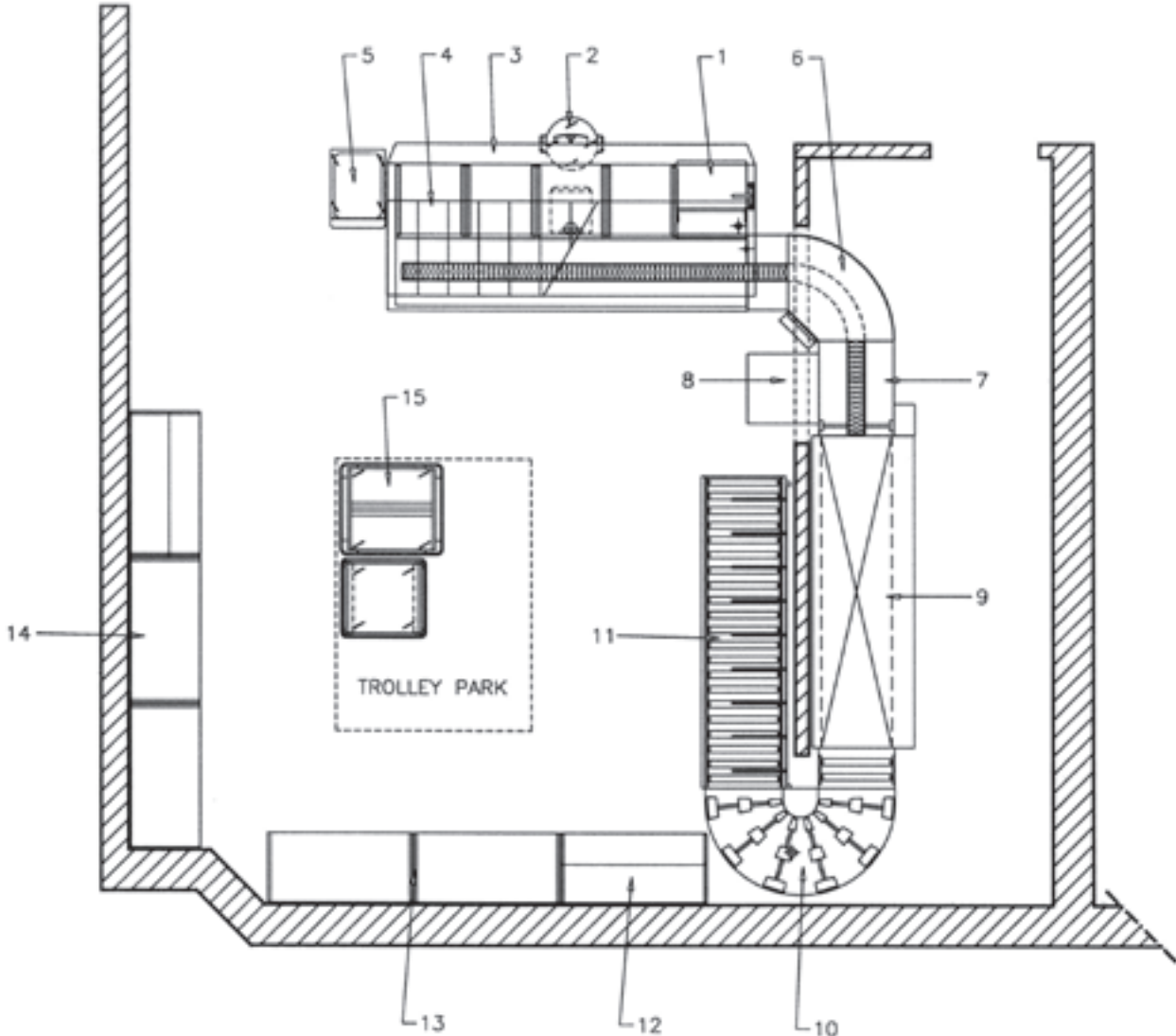

## RESTAURANT 150 - 350 SEATS

---

### A la Carte service - continuous dishwashing

The staff place the dirty goods directly in baskets on the sorting table. The cutlery is put directly in a cutlery basket at the cutlery soak unit. The leftovers are scraped off the plates with the scraper and the plates are then stacked in plate baskets. Glasses and cups are sorted into dishwashing baskets.

When the dishwashing baskets are full, they are pushed onto the basket conveyor. The full dishwashing baskets automatically move through the automatic pre-rinse unit to be washed in the dishwashing machine. An empty basket from the shelf for empty baskets replaces the full one. Trays are placed in tray baskets on the tray loading table. When the tray basket is full, it is pushed onto the basket conveyor and transported into the dishwashing machine.

The clean goods are placed on trolleys and then transported to the restaurant area, or placed directly in storage racks in the dishwashing area.

Pos	Qty	Art. nr	Description
1	1	4552030	Cutlery unit Metos 5016, lifting mechanism
2	1	4551222	Waste trolley Nordien 217, with castors
	1	4551910	Scraper Nordien 421
3	1		Base unit
	1		Conveyor extension
4	1		Sorting & basket shelf
5	1	4554320	Tray dispenser trolley Nordien TDT N-S
6	1		Curve
	1		Pre-rinse
7	1		Power unit
8	1	4552038	Tray loading table Metos fold-down type
9	1		Dishwashing machine
10	1	4552102	Conv.curve 180 Nordien 445, motor-driven
11	1	4552142	Drying line Nordien 460-4, 2110mm, on wheels
	1	4552178	Cassette holder Nordien 502T-4, 2200mm, fast
12	1	4551340	Cutlery rack Nordien 917
13	2	4551348	Storage rack Nordien 921
14	1	4551332	Serving rack Nordien 913, for 50x50 baskets
	2	4551324	Storage rack Nordien 909, for 50x50 baskets
15	1	4554314	Basket trolley Nordien BAT-8 N-S
	1	4554330	Cassette trolley Nordien PCT-12 N-S



**Metos Manufacturing**

Ahjonkaarre, FI-04220 Kerava, Finland

Tel +358 0204 3913

Fax +358 204 39 4306

e-mail: [international.sales@metos.com](mailto:international.sales@metos.com)

**[www.metos.com/manufacturing](http://www.metos.com/manufacturing)**